

NOTES:

1. ALL DIMENSIONS ARE IN MILLIMETRES.
2. ALL STEELWORK SHALL BE HOT DIP GALVANIZED.
3. ALL STEEL PIPES SHALL COMPLY WITH BS EN 10255 (MEDIUM AND HEAVY SERIES TUBES).
4. ALL WELDS SHALL BE CHIPPED, GROUND SMOOTH, BRUSHED TO REMOVE SLAG AND PROTECTED BY TWO COATS OF ZINC RICH PAINT TO BS 4652.
5. FOR DETAILS OF DISPLAY SIGN, REFER TO STD. DRG. NO. C2508.
6. WHERE STAIRCASE SITS ON GOOD QUALITY ROCK, BOLTS AND BASE PLATE CAN BE USED AS APPROPRIATE.
7. ALL EXPOSED STEELWORK SURFACES SHALL BE TREATED AND PAINTED IN ACCORDANCE WITH THE GENERAL SPECIFICATION.

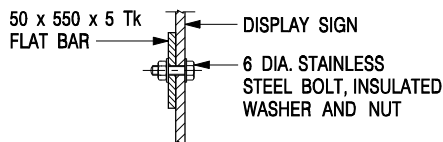
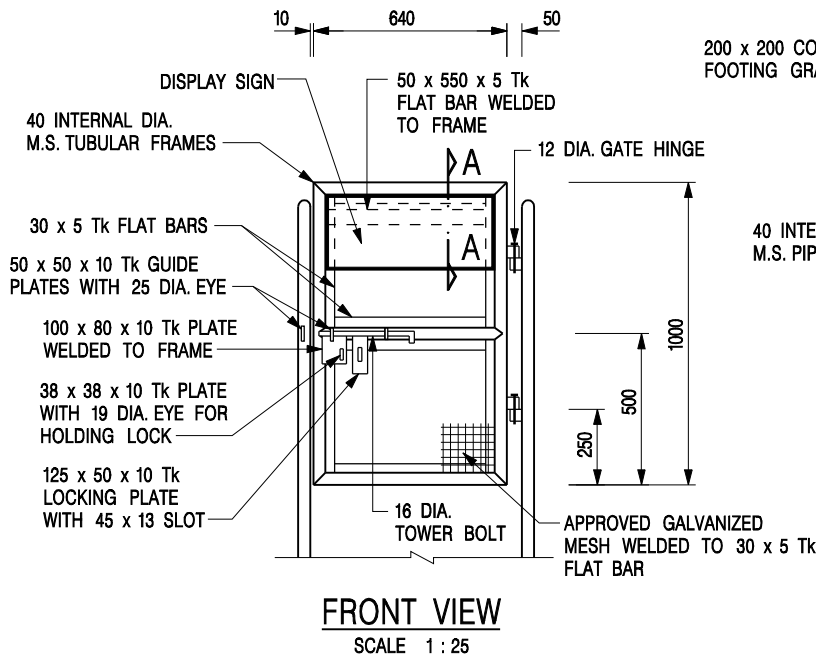
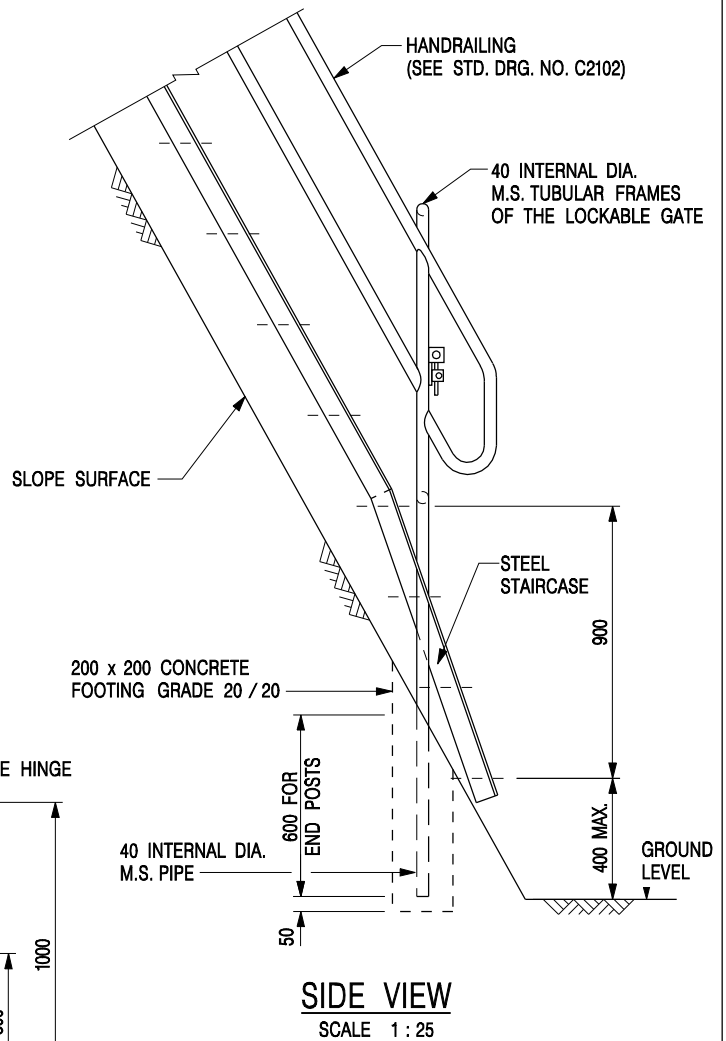

E	NOTE 3 AMENDED.	Original Signed	12.2014
D	DRAWING TITLE AMENDED.	Original Signed	02.2008
C	DRAWING TITLE AMENDED. GENERAL AMENDMENT.	Original Signed	02.2007
B	MINOR AMENDMENT.	Original Signed	01.2005
A	NOTE 5 AMENDED. NOTE 6 ADDED.	Original Signed	01.2004
-	NEW ISSUE.	Original Signed	12.2002
REF.	REVISION	SIGNATURE	DATE

**LOCKABLE GATE FOR
MAINTENANCE STAIRWAY
ON SLOPES STEEPER THAN 40°**

CEDD CIVIL ENGINEERING AND DEVELOPMENT DEPARTMENT

SCALE AS SHOWN **DRAWING NO.** C2510E

DATE DEC 2002

卓越工程 建設香港 We Engineer Hong Kong's Development