

DETAIL 'A'
 (DETAILS OF DOUBLE SIDE OPENING STEEL GRATING FOR L > 900mm)
 SCALE 1 : 20

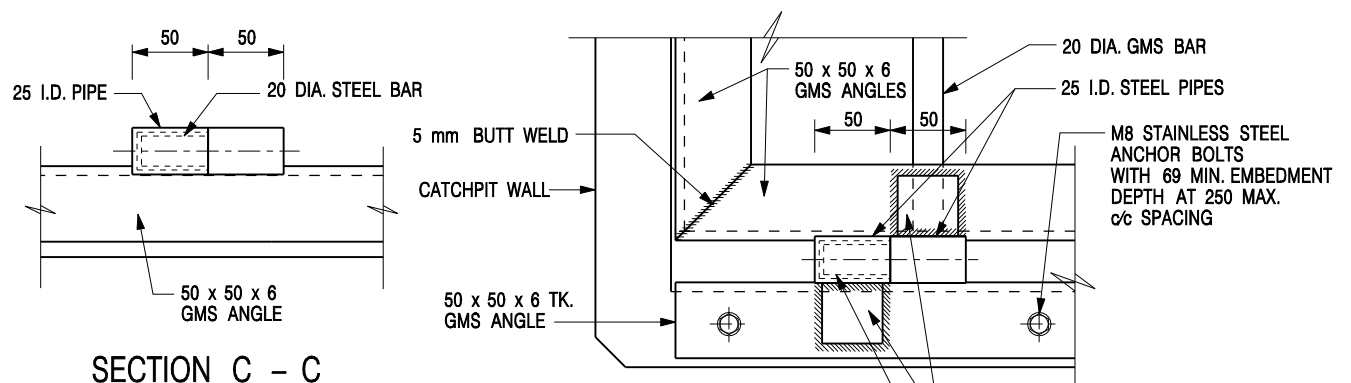

SECTION C - C

DETAIL 'C'
 (DETAILS OF HINGE)
 SCALE 1 : 5

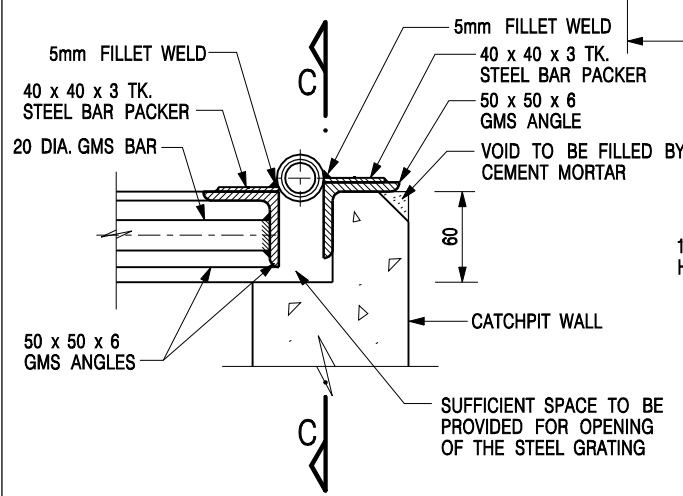

SECTIONAL ELEVATION
 (DETAIL 'C')

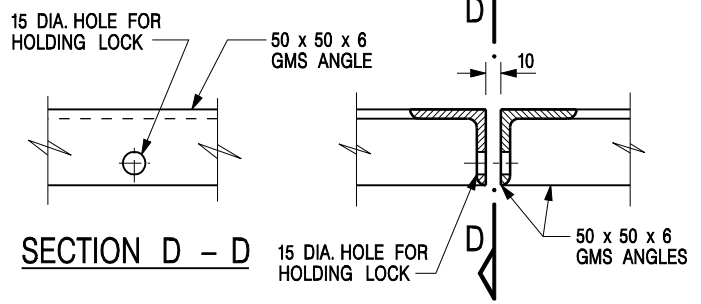

SECTION D - D

DETAIL 'D'
 (DETAILS OF HOLE FOR LOCK)
 SCALE 1 : 5

NOTES:

1. ALL DIMENSIONS ARE IN MILLIMETRES.
2. REFER TO SHEET 5 FOR OTHER NOTES.

STANDARD CATCHPIT DETAILS
 (SHEET 2 OF 5)

-	FORMER DRG. NO. C2405J.	Original Signed	03.2015
REF.	REVISION	SIGNATURE	DATE
		SCALE AS SHOWN	
		DRAWING NO. C2405 / 2	
DATE JAN 1991			