

VERTICAL / SUB-VERTICAL WALL AND SLOPE WITH GRANITE BLOCK FACING AT TOE
(DRAINAGE BEHIND VERTICAL WALL NOT SHOWN FOR CLARITY)

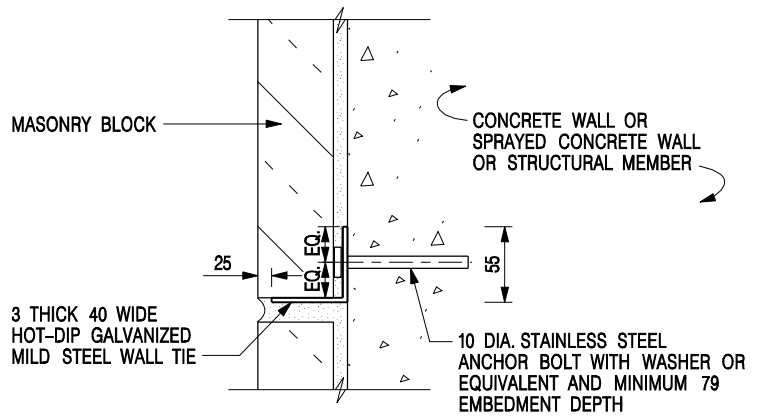
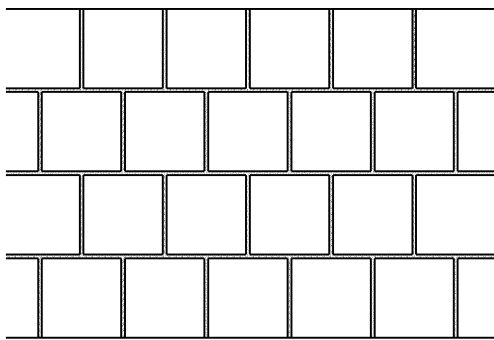

ELEVATION OF GRANITE BLOCK FACING
(SQUARE PATTERN)

DETAILS OF TIE

NOTES:

1. ALL DIMENSIONS ARE IN MILLIMETRES.
2. A TRIAL PANEL OF SIZE 1 m x 1 m SHALL BE PREPARED FOR ENGINEER'S APPROVAL.
3. WEEPHOLES SHALL BE PROVIDED AS APPROPRIATE. WHERE WEEPHOLES ARE REQUIRED, THEY SHALL BE CONSTRUCTED OF SINGLE CONTINUOUS PVC PIPES EXTENDED TO THE OUTER FACE OF THE GRANITE BLOCKS. SUBJECT TO THE ENGINEER'S AGREEMENT, WATER TIGHT SOCKETED JOINTS MAY BE PROVIDED AS AN ALTERNATIVE.
4. FOR OTHER PATTERNS, SEE STD. DRG. NO. C2002 / 2.
5. ALTERNATIVE TREATMENT TO CONCRETE SURFACE INCLUDES RIB FINISH, LARGE BLOCK PATTERN, APPLICATION OF PAINT AND SPRAYED GRANITE.
6. TIES SHALL BE LAID AT A RATE OF 5 NOS. PER m². FOR WALLS HIGHER THAN 2.5 m, THE ENGINEER SHALL SPECIFY THE NUMBER OF TIES PER m².
7. ALL STAINLESS STEEL ANCHOR BOLTS AND WASHERS SHALL HAVE A DECLARATION OF PERFORMANCE FOR THE CONSTRUCTION PRODUCT COVERED BY A EUROPEAN TECHNICAL ASSESSMENT REPORT ETAG 001 OR APPROVED EQUIVALENT.

F	NOTE 7 ADDED. DETAILS FOR ANCHOR BOLT REVISED.	Original Signed	07.2018
E	MINOR AMENDMENT.	Original Signed	03.2015
D	DETAILS OF WALL TIE REVISED.	Original Signed	09.2007
C	GENERAL REVISION.	Original Signed	12.2005
B	GENERAL REVISION.	Original Signed	01.2005
A	GENERAL REVISION.	Original Signed	12.2002
REF.	REVISION	SIGNATURE	DATE

**STONE FACING TO
CONCRETE SURFACES**
(SHEET 1 OF 2)



**CIVIL ENGINEERING AND
DEVELOPMENT DEPARTMENT**

SCALE DIAGRAMMATIC

DRAWING NO.

DATE JAN 1991

C2002 /1F