

DETAIL 3

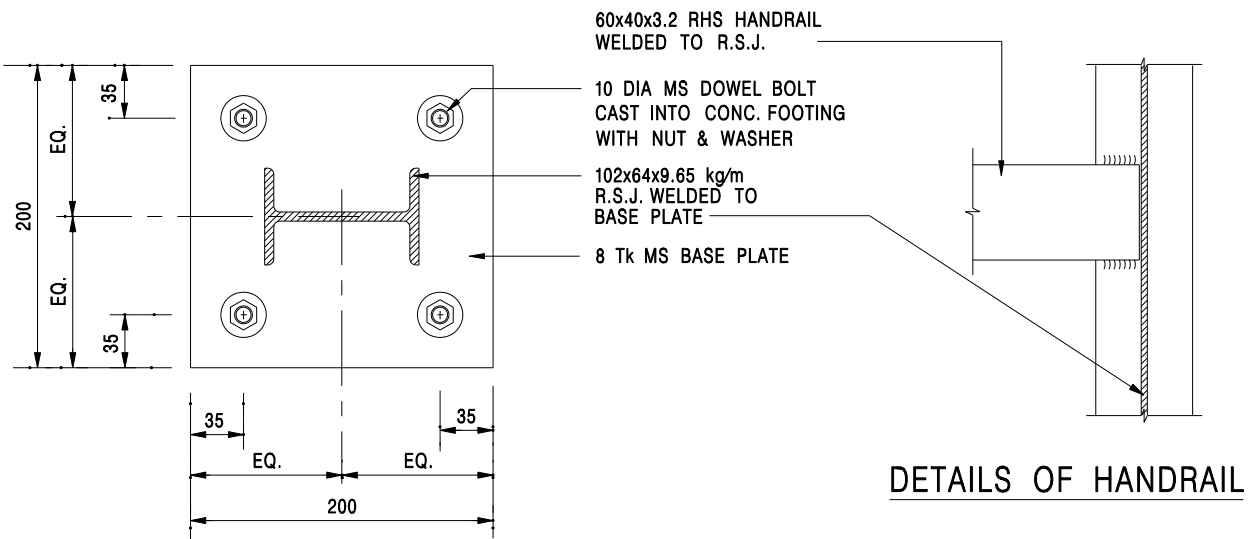

DETAILS OF BASE PLATE

DETAILS OF HANDRAIL

G	MINOR AMENDMENT & TITLE AMENDED	Original Signed	03.2015
F	NOTE AMENDED	Original Signed	09.2007
E	NAME OF DEPARTMENT AMENDED	Original Signed	02.2005
D	NOTES REVISED	Original Signed	02.2004
REF.	REVISION	SIGNATURE	DATE

**HOARDING TYPE II
(SHEET 4 OF 5)**

CEDD CIVIL ENGINEERING AND DEVELOPMENT DEPARTMENT

SCALE 1 : 5 DRAWING NO. C1005/4G
DATE JAN 1991