

0.5 Tk CORRUGATED STEEL SHEET COVERING

50 LONG 40x40x5 MS ANGLE CLEAT WELDED TO RAFTER BEHIND

60x60x5 Tk MS WEB PLATE WELDED TO RUNNER

8 NOS. OF 50x50x5 MS ANGLE RAFTER WITH SLOT FOR GATEWAY

2 NOS. OF 40x40x5 MS ANGLE PURLIN WITH SLOTS FOR FIXING TO ANGLE CLEAT

SILICONE SEALANT POINTING ALONG JOINT AT THE BOTTOM OF CORRUGATED STEEL SHEET COVERING

40x40x5 MS ANGLE PURLIN

60x60x6 MS ANGLE RUNNER

CORRUGATED STEEL SHEET CLADDING

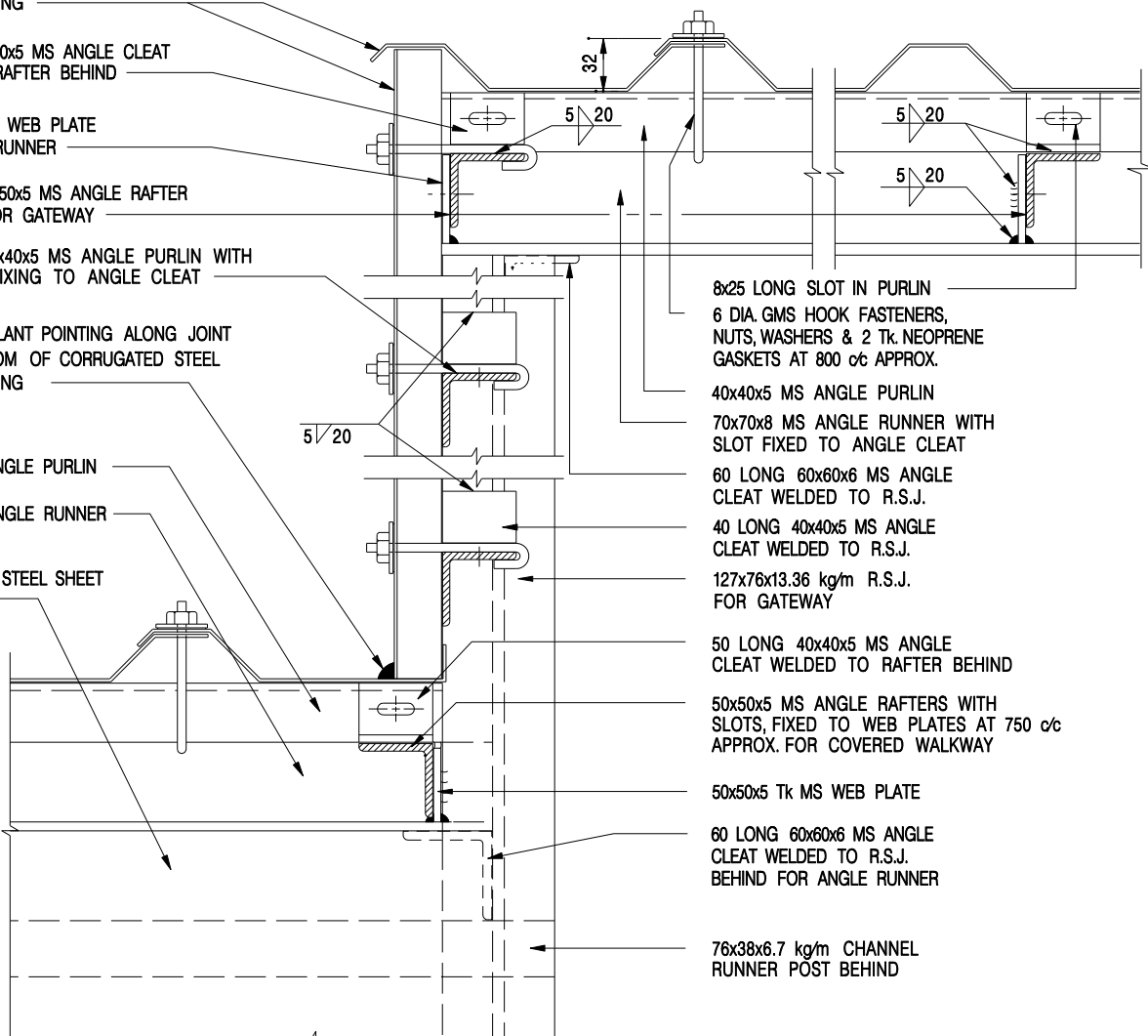

8x25 LONG SLOT IN PURLIN
6 DIA. GMS HOOK FASTENERS, NUTS, WASHERS & 2 Tk. NEOPRENE GASKETS AT 800 c/c APPROX.

40x40x5 MS ANGLE PURLIN
70x70x8 MS ANGLE RUNNER WITH SLOT FIXED TO ANGLE CLEAT

60 LONG 60x60x6 MS ANGLE CLEAT WELDED TO R.S.J.

40 LONG 40x40x5 MS ANGLE CLEAT WELDED TO R.S.J.

127x76x13.36 kg/m R.S.J. FOR GATEWAY

50 LONG 40x40x5 MS ANGLE CLEAT WELDED TO RAFTER BEHIND

50x50x5 MS ANGLE RAFTERS WITH SLOTS, FIXED TO WEB PLATES AT 750 c/c APPROX. FOR COVERED WALKWAY

50x50x5 Tk MS WEB PLATE

60 LONG 60x60x6 MS ANGLE CLEAT WELDED TO R.S.J. BEHIND FOR ANGLE RUNNER

76x38x6.7 kg/m CHANNEL RUNNER POST BEHIND

DETAIL 1

0.75 Tk GALV. STEEL SHEET FASCIA WITH 150 MIN. OVERLAPPING JOINTS

40x40x5 MS ANGLE PURLIN FIXED TO ANGLE CLEAT

60x60x5 Tk (FOR GATEWAY) / 50x50x5 Tk (FOR COVERED WALKWAY) MS WEB PLATE

8x25 LONG SLOT IN PURLIN, RAFTER & ANGLE RUNNER FOR BOLT

M8 GMS BOLTS & NUTS

70x70x8 (FOR GATEWAY) / 60x60x6 (FOR COVERED WALKWAY) MS ANGLE RUNNER FIXED TO ANGLE CLEAT

60 LONG 60x60x6 MS ANGLE CLEAT WELDED TO R.S.J.

127x76x13.36 kg/m R.S.J. (FOR GATEWAY) /

102x64x9.65 kg/m R.S.J. (FOR COVERED WALKWAY)

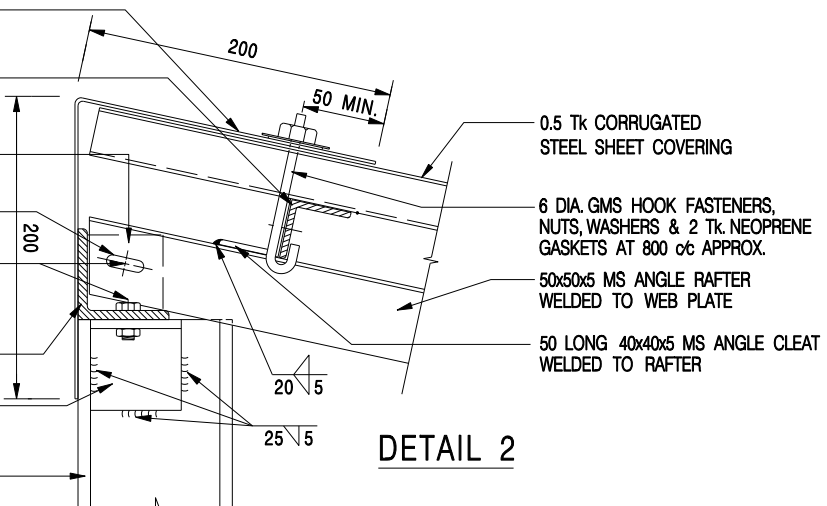

0.5 Tk CORRUGATED STEEL SHEET COVERING

6 DIA. GMS HOOK FASTENERS, NUTS, WASHERS & 2 Tk. NEOPRENE GASKETS AT 800 c/c APPROX.

50x50x5 MS ANGLE RAFTER WELDED TO WEB PLATE

50 LONG 40x40x5 MS ANGLE CLEAT WELDED TO RAFTER

DETAIL 2

G	MINOR AMENDMENT & TITLE AMENDED	Original Signed	03.2015
F	NOTE AMENDED	Original Signed	09.2007
E	NAME OF DEPARTMENT AMENDED	Original Signed	02.2005
D	NOTES REVISED	Original Signed	02.2004
REF.	REVISION	SIGNATURE	DATE

**HOARDING TYPE II
(SHEET 3 OF 5)**



CIVIL ENGINEERING AND DEVELOPMENT DEPARTMENT

SCALE 1 : 5

DRAWING NO.

DATE JAN 1991

C1005/3G