

SECTIONAL ELEVATION

DETAIL 'B'

(DETAILS OF SINGLE SIDE OPENING STEEL GRATING FOR $L \leq 900$ mm)

SCALE 1 : 20

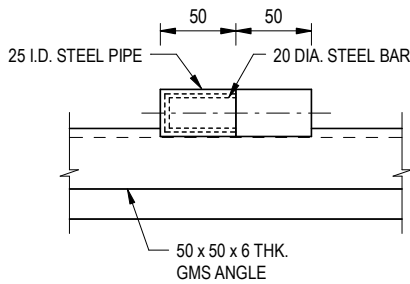

SECTION E - E

SCALE 1 : 5

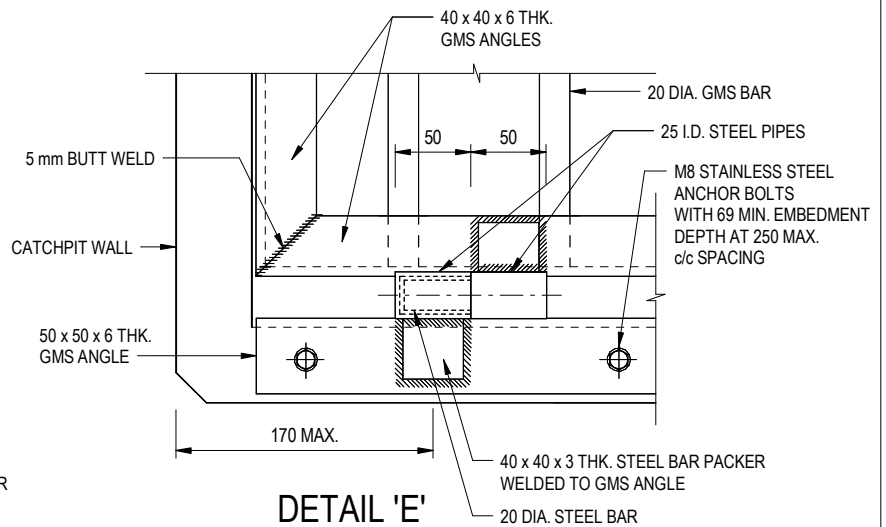

DETAIL 'E'
(DETAILS OF HINGE)

SCALE 1 : 5

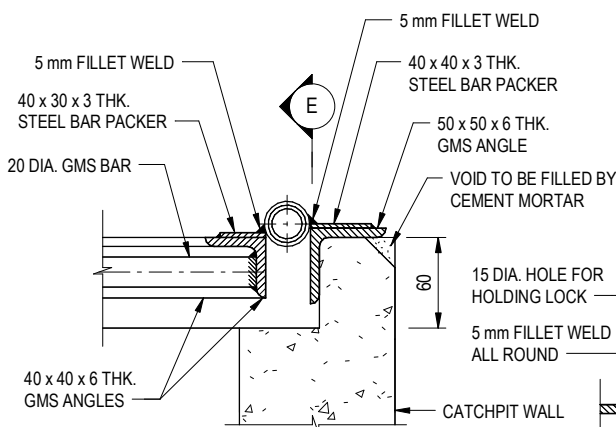

SECTIONAL ELEVATION

(DETAIL 'E')

SCALE 1 : 5

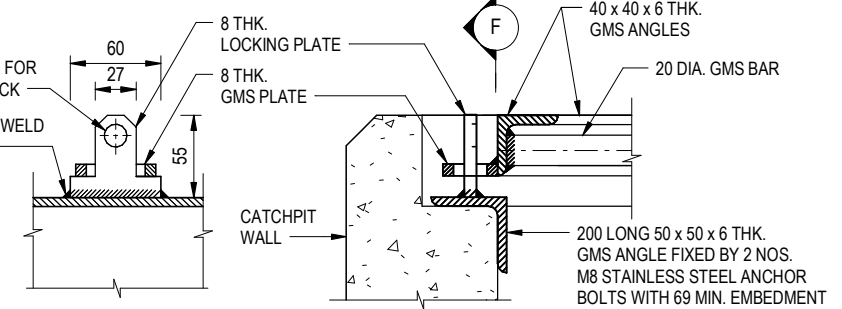

SECTION F - F

SCALE 1 : 5

DETAIL 'F'
(DETAILS OF LOCKING PLATE)

SCALE 1 : 5

NOTES:

1. ALL DIMENSIONS ARE IN MILLIMETRES.
2. REFER TO SHEET 5 FOR OTHER NOTES.

A	BIM OBJECT REVISION.	Original Signed	12.2025
-	FORMER DRG. NO. C2405J.	Original Signed	03.2015
REF.	REVISION	SIGNATURE	DATE

**STANDARD CATCHPIT DETAILS
(SHEET 3 OF 5)**



**CIVIL ENGINEERING AND
DEVELOPMENT DEPARTMENT**

SCALE AS SHOWN

DRAWING NO.

DATE JAN 1991

C2405 /3A