

DETAIL 'A'

(DETAILS OF DOUBLE SIDE OPENING STEEL GRATING FOR L > 900 mm)

SCALE 1 : 20

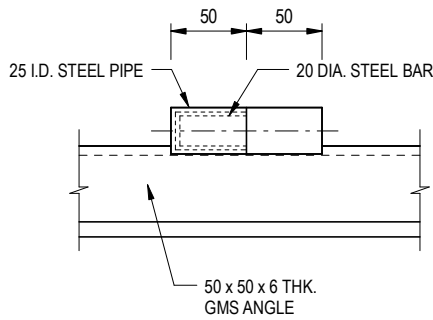

SECTION C - C

SCALE 1 : 5

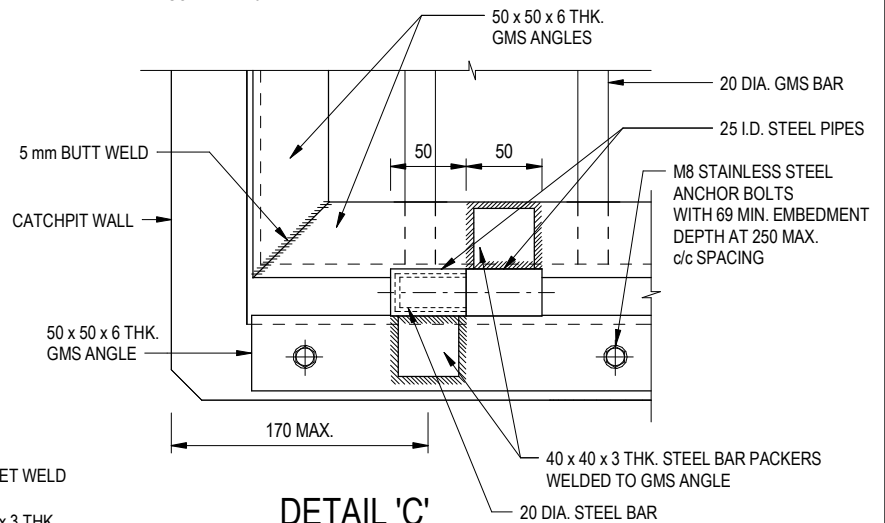

DETAIL 'C'
(DETAILS OF HINGE)

SCALE 1 : 5

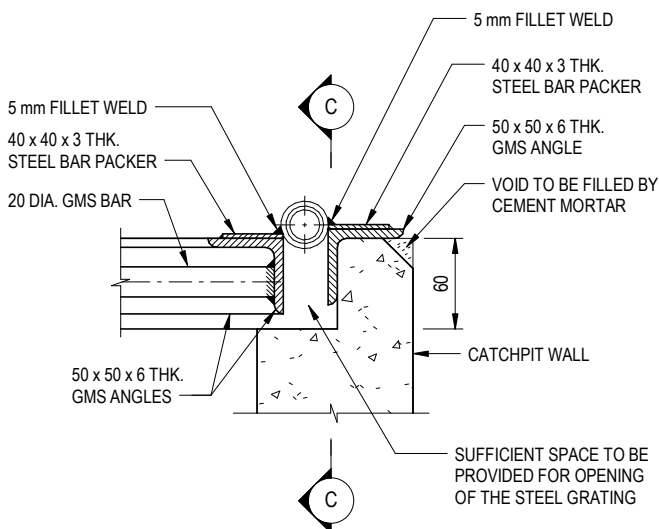

SECTIONAL ELEVATION
(DETAIL 'C')

SCALE 1 : 5

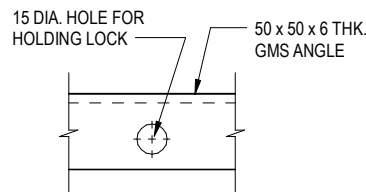

SECTION D - D

SCALE 1 : 5

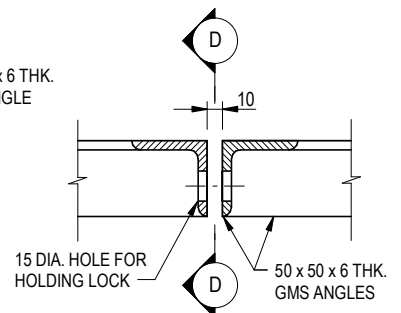

DETAIL 'D'

(DETAILS OF HOLE FOR LOCK)

SCALE 1 : 5

NOTES:

1. ALL DIMENSIONS ARE IN MILLIMETRES.
2. REFER TO SHEET 5 FOR OTHER NOTES.

A	BIM OBJECT REVISION.	Original Signed	12.2025
-	FORMER DRG. NO. C2405J.	Original Signed	03.2015
REF.	REVISION	SIGNATURE	DATE

**STANDARD CATCHPIT DETAILS
(SHEET 2 OF 5)**



**CIVIL ENGINEERING AND
DEVELOPMENT DEPARTMENT**

SCALE AS SHOWN

DRAWING NO.

DATE JAN 1991

C2405 /2A