

**Geoguide 6**

# **Guide to Reinforced Fill Structure and Slope Design**

**Geotechnical Engineering Office  
Civil Engineering and Development Department  
The Government of the Hong Kong  
Special Administrative Region**

# **Guide to Reinforced Fill Structure and Slope Design**

**Geotechnical Engineering Office  
Civil Engineering and Development Department  
The Government of the Hong Kong  
Special Administrative Region**

© The Government of the Hong Kong Special Administrative Region  
 First published, December 2002  
 Continuously updated e-version, 29 August 2017  
 Continuously updated e-version, 27 October 2022

Prepared by Professor Colin J. F. P. Jones, University of Newcastle upon Tyne,  
 Newcastle upon Tyne, NE1 TRR, United Kingdom, for:

Geotechnical Engineering Office,  
 Civil Engineering and Development Department,  
 Civil Engineering Building,  
 101 Princess Margaret Road,  
 Homantin, Kowloon,  
 Hong Kong.

Principal Author: Professor Colin J. F. P. Jones

Steering Committee:

R. K. S. Chan (Chairman)  
 J. B. Massey  
 M. C. Tang  
 Y. C. Chan  
 S. H. Mak  
 P. L. R. Pang  
 K. C. Lam  
 A. Y. T. Lam (Secretary)

Working Group:

K. C. Lam (Chairman since 11.2.2002)  
 K. P. Yim (Chairman before 9.2.2002)  
 A. Y. T. Lam  
 K. W. K. Lau  
 S. C. Leung  
 C. M. Ting  
 H. M. Tsui  
 M. N. K. Chan  
 D. K. M. Wong  
 K. W. Shum (since 1.3.2002)

This Geoguide is a continuously updated version incorporating amendments issued since the Geoguide was published. The continuously updated version is released in e-format only on the CEDD website. This Geoguide is to be cited as “GEO (2022). Guide to Reinforced Fill Structure and Slope Design (Geoguide 6) (Continuously Updated E-Version released on 27 October 2022). Geotechnical Engineering Office, Civil Engineering and Development Department, HKSAR Government, 218 p.” It is a companion to the latest version of Geoguide 1 - Guide to Retaining Wall Design.

## Foreword

This Geoguide presents a recommended standard of good practice for the design and construction supervision of permanent reinforced fill features in Hong Kong. It is a companion to Geoguide 1 – Guide to Retaining Wall Design (2020) and is aimed at qualified engineers who are conversant with the relevant engineering principles and procedures. It supersedes Geospec 2 – Model Specification for Reinforced Fill Structures (1989) and GEO Report No. 34 – A Partial Factor Method for Reinforced Fill Slope Design (1993). [Amd GG6/01/2022]

The Geoguide also provides a Model Specification which stipulates the general requirements on the quality of materials, standard of workmanship, testing methods and acceptance criteria for reinforced fill construction. The Model Specification given in Appendix A of the Geoguide serves as a reference for practitioners in the preparation of particular specification for the construction of reinforced fill structure and slope. Modifications would be necessary to suit individual situations and contract requirements.

The Geoguide was prepared by Professor Colin J.F.P. Jones of the University of Newcastle upon Tyne, United Kingdom and a Working Group under the overall direction of a Steering Committee from the GEO. The membership of the Steering Committee and the Working Group is given on the opposite page.

To ensure that the Geoguide would be considered a consensus document by interested parties in Hong Kong, a draft version was circulated locally and abroad for comment in August 2002. Those consulted included consulting engineers, contractors, manufacturers of reinforced fill products, academics, professional bodies and Government departments. Many individuals and organisations made very useful comments, which have been taken into account in finalising the Geoguide, and their contributions are gratefully acknowledged.

As with other Geoguides, this document gives guidance on good engineering practice, and its recommendations are not intended to be mandatory. It is recognised that experienced practitioners may wish to use alternative methods to those recommended herein. Practitioners are encouraged to comment at any time to the Geotechnical Engineering Office on the contents of this Geoguide, so that improvements can be made to future editions.



R. K. S. Chan

Head, Geotechnical Engineering Office  
Civil Engineering Department  
December 2002

## Contents

	Page No.
Title Page	1
Foreword	3
Contents	4
1 Introduction	11
1.1 Purpose and Scope	11
1.2 Historical Development	12
2 Applications	14
2.1 Areas of Application	14
2.1.1 General	14
2.1.2 Transportation	14
2.1.3 Housing	14
2.1.4 Slope Stabilization and Landslide Mitigation	14
2.1.5 Other Common Usage	15
2.2 Advantages and Limitations	15
2.2.1 Advantages	15
2.2.2 Sustainable Development	16
2.2.3 Limitations	17
2.3 Types of Reinforced Fill systems	18
2.3.1 General	18
2.3.2 Elemental System	18
2.3.3 Full Height System	19
2.3.4 Wrap-around System	19
2.3.5 Segmental Block System	19
2.3.6 Anchored Earth System	20
2.4 Selection of Systems	20
2.5 Proprietary Aspects	20

	Page No.	
3	Concepts and Principles of Reinforced Fill	21
3.1	General	21
3.2	Mechanism of Reinforced Fill	21
	3.2.1 Load Transfer Mechanism	21
	3.2.2 Shear Resistance	22
3.3	Factors Affecting the Behaviour of Reinforced Fill	22
	3.3.1 General	22
	3.3.2 Strain Compatibility	22
	3.3.3 Reinforcement Properties	23
	3.3.4 Reinforcement Distribution	24
	3.3.5 Fill Properties	25
	3.3.6 Fill State	26
	3.3.7 Construction	27
	3.3.8 Foundation	28
3.4	Interaction between Fill and Reinforcement	28
	3.4.1 General	28
	3.4.2 Pullout Resistance	28
	3.4.3 Direct Sliding Resistance	30
4	Construction Materials	32
4.1	Reinforcement	32
	4.1.1 General	32
	4.1.2 Metallic Reinforcement	32
	4.1.3 Polymeric Reinforcement	32
	4.1.4 Durability	33
	4.1.5 Corrosion of Metallic Reinforcement	33
	4.1.6 Degradation of Polymeric Reinforcement	34
	4.1.7 Creep and Stress Rupture of Polymeric Reinforcement	36
	4.1.8 Temperature Effects	36
	4.1.9 Construction Damage	37
	4.1.10 Connections	37

	Page No.	
4.2	Facings and Connections	38
4.2.1	General	38
4.2.2	Hard Facings	38
4.2.3	Flexible Facings	39
4.2.4	Facing Connections	39
4.3	Fill Materials	40
4.4	Filter and Drainage Materials	40
4.4.1	Granular Filter and Drainage Materials	40
4.4.2	Geotextile Filter Materials	40
5	Investigation and Testing	42
5.1	General	42
5.2	Site Investigation	42
5.3	Investigation of Sources of Fill Materials	42
5.4	Sampling and Testing of Fill Materials	43
5.5	Testing of Reinforcement and Connections	43
6	Design Considerations	45
6.1	General	45
6.2	Design Situations	45
6.2.1	General	45
6.2.2	Design Life	46
6.2.3	Loading Conditions	46
6.3	Selection of Reinforced Fill Systems	46
6.4	Limit States and Modes of Instability	47
6.4.1	Limit States	47
6.4.2	Modes of Instability	48
6.5	Factors of Safety	48
6.5.1	General	48
6.5.2	Overall Stability	48
6.5.3	Partial Factors	49

	Page No.	
6.6	Design Strengths	51
	6.6.1 Reinforcement	51
	6.6.2 Fill Materials	52
	6.6.3 Fill-to-Reinforcement Interaction	52
	6.6.4 Facing Units Interaction	52
	6.6.5 Facing Elements	53
6.7	Construction Tolerances and Serviceability Limits	53
	6.7.1 General	53
	6.7.2 Construction Tolerances	53
	6.7.3 Settlement	54
6.8	Design Detailing, Construction Procedure and Logistics	54
6.9	Protection of Reinforcement	55
	6.9.1 General	55
	6.9.2 Metallic Reinforcement	55
	6.9.3 Polymeric Reinforcement	55
6.10	Prior Acceptance of Proprietary Reinforcement	56
6.11	Performance Monitoring	56
6.12	Maintenance and Urgent Repair	57
6.13	Services	58
7	Design of Reinforced Fill Structures	59
	7.1 General	59
	7.2 Basic for Design	59
	7.3 Dimensions of the Structure	60
	7.4 External Stability	60
	7.4.1 Overall Stability	60
	7.4.2 Stability of the Reinforced Block	61
	7.5 Internal Stability	62
	7.5.1 General	62
	7.5.2 Design Methods	62
	7.5.3 Tension in Reinforcement	64



	Page No.	
7.5.4	Local Stability Check	65
7.5.5	Wedge Stability Check	66
7.6	Compound Stability	67
7.6.1	General	67
7.6.2	Rupture/Pullout of Reinforcement	67
7.6.3	Sliding on Planes between Reinforcement	68
7.6.4	Sliding along Reinforcement	68
7.7	Serviceability Considerations	68
7.7.1	Serviceability Check	68
7.7.2	Differential Settlement	69
7.8	Spacing of Reinforcement	70
7.9	Design of Connections	70
7.9.1	Failure of Connections	70
7.9.2	Metallic Connections	71
7.9.3	Polymeric Connections	71
7.10	Design of Facing Elements	71
7.10.1	Hard Facings	71
7.10.2	Flexible Facings	72
7.11	Drainage Provisions	72
7.11.1	Design Aspects	72
7.11.2	Design Detailing	73
7.11.3	Temporary Drainage	74
7.12	Superimposed Walls	74
7.13	Segmental Block Walls	75
7.13.1	General	75
7.13.2	Design of Facing	75
7.14	Walls with a Stepped Base	77
7.15	Back-to-Back Walls	78
7.16	Bridge Abutments	78
7.16.1	General	78

	Page No.	
7.16.2	Abutments on Spread Footings	79
7.16.3	Abutments on Piled Foundations	79
7.17	Design Detailing	80
7.17.1	Corner and Wall Joint Details	80
7.17.2	Termination to Cast-in-place Structures	80
8	Design of Reinforced Fill Slopes	81
8.1	General	81
8.2	Basis for Design	81
8.3	External Stability	82
8.4	Internal Stability	82
8.4.1	Modes of Internal Failure	82
8.4.2	Tension in Reinforcement	83
8.4.3	Local Stability Check	84
8.5	Compound Stability	85
8.6	Serviceability Considerations	85
8.7	Spacing of Reinforcement	85
8.8	Design Detailing	85
8.8.1	Facing Details	85
8.8.2	Drainage Details	86
9	Aesthetics and Landscaping	87
9.1	General	87
9.2	Design Detailing	87
9.3	Construction Practice	88
9.4	Long-term Aesthetic Appearance	89
10	Procurement and Specification	90
10.1	General	90
10.2	Contract and Specification	90
10.2.1	Types of Contract	90
10.2.2	Conventional Contract	90
10.2.3	Design and Build Contract	90

	Page No.
10.2.4 Model Specification	91
10.3 Suitability of Contractors	91
10.4 Patents and Client's Indemnification	92
11 Construction Control	93
11.1 General	93
11.2 Construction Supervision	93
11.2.1 General	93
11.2.2 Pre-construction Review	94
11.2.3 Construction Method and Sequence	95
11.2.4 Preparation of Foundation	95
11.2.5 Temporary Drainage	96
11.2.6 Storage and Installation of Facing and Reinforcing Elements	96
11.2.7 Deposition and Compaction of Fill and Filter/Drainage Layers	97
11.2.8 Testing of Materials	98
References	99
Tables	107
List of Tables	108
Tables	109
Figures	116
List of Figures	117
Figures	121
Appendix A Model Specification for Reinforced Fill Structures and Slopes	180
Appendix B Model Checklist for Reinforced Fill Construction Control	205
Glossary of Symbols	209
Glossary of Terms	216

# 1 Introduction

## 1.1 Purpose and Scope

This Geoguide recommends a standard of good practice for the design and construction supervision of permanent reinforced fill structures and slopes in Hong Kong. It is a companion to Geoguide 1 – Guide to Retaining Wall Design (GEO, 2020) and is aimed at qualified engineers who are conversant with the relevant engineering principles and procedures.

[Amd GG6/01/2022]

Reinforced fill is a compacted mass of fill with predominantly horizontal layered reinforcing elements to improve its tensile and shear capacities. Permanent reinforced fill features are made of reinforced fill, which may also comprise facing elements to form slopes or structures with an intended design life longer than two years. A reinforced fill feature with a face inclination of more than 20° from the vertical shall be considered as a reinforced fill slope. A reinforced fill feature otherwise shall be considered as a reinforced fill structure.

The geotechnical standards set out in this Geoguide is for new permanent reinforced fill features, including retaining walls, bridge abutments, segmental block retaining walls and reinforced fill slopes. Temporary reinforced fill structures and slopes can also be designed using the document. The Geoguide does not cover soil nailing, reinforced fill dams, maritime structures, structures which are in an estuarine or marine environment, reinforced fill foundations for embankments on soft ground and the stability assessment of existing reinforced fill structures and slopes.

General considerations relating to potential applications, advantages and limitations of different reinforced fill systems are provided in Chapter 2. The concept and principles of reinforced fill, together with the factors that affect the behaviour of reinforced fill are explained in Chapter 3. In addition, general design formulae for assessing interaction between fill and reinforcement (i.e. pullout and direct sliding resistance) are provided for various forms of reinforcement (i.e. strips, grids sheets, anchors) in Chapter 3.

Details of the construction materials commonly used to form reinforced fill structures and slopes are given in Chapter 4. Chapter 5 covers the specific ground investigation and testing associated with the design and construction of reinforced fill features.

In line with Geoguide 1, the limit state approach has been adopted in this Geoguide. The appropriate partial safety factors on loading, materials and fill-reinforcement interaction, together with the factors which need to be considered in design are given in Chapter 6.

Guidance on the design of reinforced fill structures including segmental block retaining walls is given in Chapter 7. Chapter 8 covers the design of reinforced fill slopes.

Guidance on aesthetics and landscape treatment of reinforced fill structures and slopes is covered in Chapter 9. The procurement of and specification for reinforced fill construction relating to common construction practices are addressed in Chapter 10.

Guidance on construction control is given in Chapter 11.

There are a few terms used with specific meanings in this Guide. These meanings are given in the Glossary of Terms at the end of the document.

## 1.2 Historical Development

The concept of reinforced fill is not new. The basic principles are demonstrated abundantly in nature by animals and birds and the action of tree roots. Constructions using the technique are known to have existed in the 5th and 4th millennia BC.

The earliest remaining examples of reinforced fill are the ziggurat of the ancient city of Dur-Kurigatzu, now known as Agar-Quf, and the Great Wall of China. The Agar-Quf ziggurat, which stands five kilometers north of Baghdad, was constructed of clay bricks varying in thickness between 130 and 400 mm, reinforced with woven mats of reed laid horizontally on a layer of sand and gravel at vertical spacings varying between 0.5 and 2.0 m. Reeds were also used to form plaited ropes approximately 100 mm in diameter which pass through the structure and act as reinforcement (Bagir, 1944). The Great Wall of China, parts of which were completed circa 200 BC, contains examples of reinforced fill; in this case use was made of mixtures of clay and gravel reinforced with tamarisk branches (Department of Transport, 1977).

In the past, reinforced fill structures appear to have been used often in the control of rivers through training works and dykes. Early examples of dyke systems using reed reinforcement and clay fill are known to have existed along the Tigris and Euphrates, well before the adoption of the technique by the Romans. The use of faggoting techniques by the Dutch and the reclamation of the Fens in England are well recorded, as is the construction of the Mississippi levees in the United States.

The Romans and the Gauls made use of reinforced fill in the construction of fortifications, the technique being to form alternate layers of logs and earth fill (Duncan, 1855). Reinforcing techniques for military earthworks have been in common use up to the present day. In 1822 Colonel Pasley introduced a form of reinforced fill for military construction in the British Army (Pasley, 1822). He conducted a comprehensive series of trials and showed that a significant reduction could be made in the lateral pressures acting on retaining walls if the backfill was reinforced by horizontal layers of brushwood, wooden planks or canvas; similar observations were made with modern reinforced fill over 150 years later (Saran et al, 1975).

The reinforcement of dam structures was introduced at the beginning of the twentieth century by Reed (Reed, 1904) who advocated the use of railway lines to reinforce rockfill in the downstream face of dams in California. A similar technique, but using grids made up of three-quarter-inch diameter steel bars, was used as late as 1962 in Papua (Fraser, 1962). Other applications of the latter system have been reported in South Africa, Mexico and Australia. Recently, the construction of reinforced fill dams has again been found to be economical (Cassard et al, 1979).

The modern concept of reinforced fill was proposed by Casagrande who idealized the problem in the form of a weak soil reinforced by high-strength membranes laid horizontally in

layers (Westergaard, 1938). The modern form of reinforced fill was introduced by Vidal in the 1960s (Vidal, 1966). Vidal's concept was for a composite material formed from flat reinforcing strips laid horizontally in a frictional fill, the interaction between the fill and the reinforcing members being solely by friction generated by gravity.

In the 1970s fundamental studies of reinforced fill were sponsored by various national bodies, notably at the Laboratoire des Ponts et Chaussées (LCPC) in France (Schlosser, 1978), by the United States Department of Transportation (Walkinshaw, 1975) and by the United Kingdom Department of Transport (Murray, 1977). This work led to the introduction of improved forms of reinforcement and to a better understanding of the fundamental concepts involved.

Reinforcing material development is interrelated with reinforced fill structure developments. Whereas the early reinforced fill structures were formed using organic materials such as timber, straw or reed as reinforcement, the British Army in 1822 recognised the potential of more advanced forms of reinforcement, particularly in the use of canvas as a reinforcing membrane. The use of textiles for reinforcement could not be contemplated until the development of synthetic polymer-based materials. Synthetic fabrics were known prior to 1940 but it was not until the late 1960s and early 1970s that the advances in synthetic fabric and geotextile developments led to the construction of geosynthetic reinforced fill structures.

The first reinforced fill structure in Hong Kong, a wall measuring 11 m high and 60 m long, was constructed in 1981. Between 1981 and 2001 about 95 reinforced fill features had been, or were in the process of being constructed (Figure 1). Many of these structures are situated in the new towns such as Tuen Mun, Yuen Long and Tsing Yi, which were developed in the 1980s to accommodate the increasing population. Extensive use of reinforced fill structures has been made on the West Rail Project (Lam et al, 2001a).

The most common usage of the reinforced fill technique in Hong Kong is either as retaining walls or fill slopes in association with site formation works for highways, railways and building platforms. Other applications involve highway bridge abutments, slope repairs, river training works and blast shelters. As shown in Figure 1, most of the completed reinforced fill features are ranged between 5 and 15 m in height, but a reinforced fill wall up to about 40 m was constructed on the mountainous coastal terrain of North West Tsing Yi to support a highway interchange that links Route 3 with the North Lantau Expressway.

A comprehensive study of the historical development of reinforced fill can be found in Jones (1996).

## **2 Applications**

### **2.1 Areas of Application**

#### **2.1.1 General**

Applications of reinforced fill can be conveniently grouped to cover transportation, housing, slope stabilization, landslide mitigation and other common applications (Jones, 1996). This Chapter catalogues some of the application areas for the use of reinforced fill and illustrates where reinforced fill of various forms have been found to provide economical and technical benefits. Each case is an illustration of the concept of reinforced fill application but should not be taken as being the only effective or rational solution to any problem.

#### **2.1.2 Transportation**

The widest use of reinforced fill is the construction of new highway and railway infrastructure. Reinforced fill permits the formulation of solutions which may not be technically possible using conventional structures. Applications where economical and technical benefits have been achieved using reinforced fill include:

- (a) bridge abutments and bridge wing walls,
- (b) retaining walls,
- (c) embankments, and
- (d) construction on sloping ground.

Figure 2 illustrates the use of reinforced fill in highway and railway application.

#### **2.1.3 Housing**

Reinforced fill is commonly used in housing applications to produce structural platforms and terracing (Figure 3). In housing development where low height retaining walls are commonly adopted, segmental block system (see Section 2.3.5) are particularly applicable, as they can be constructed with the minimum use of plant, and may be formed using indigenous fill.

#### **2.1.4 Slope Stabilization and Landslide Mitigation**

Reinforced fill can be used to repair failed slopes. An advantage of the technique is that it is often possible to reuse the landslide debris for the reconstruction of the failed slope. Although not always possible, in some situations the reconstructed slope can also be accommodated in the original land take (i.e. no additional land is required), Figure 4(a).

Barriers can be constructed using the reinforced fill technique to mitigate against natural

terrain landslide and boulder fall hazards (Figure 4(b)).

### **2.1.5 Other Common Usage**

Reinforced fill can be used in a number of diverse applications, including the construction of river training structures (Figure 5(a)). The speed of construction and their adaptability to accept significant distortion without any loss of serviceability makes reinforced fill structures ideally suited to industrial applications. Because of their tolerance to distortion, construction with minimal foundation preparation is possible, resulting in very economical structures. Industrial reinforced fill structures such as crushing plants and material storage facilities can be built using widely available and easily transported materials (Figure 5(b) & (c)).

## **2.2 Advantages and Limitations**

### **2.2.1 Advantages**

Reinforced fill structures and slopes could offer technical and economical advantages over conventional forms of construction. Reinforced fill structures could normally achieve 20 to 50 % saving in capital cost when compared with conventional retaining structures. In many cases the primary advantage gained from the use of reinforced fill is the improved idealisation which the concept permits; thus structural forms which normally would have been difficult or impossible become feasible and economical.

An example of economical benefit is illustrated in Figure 6(a). In Hong Kong, there have been cases where the flexibility of reinforced fill allows tall retaining structures to be founded on sloping ground without the need for a piled foundation (Raybould et al, 1996; Lam, et al, 2001). When constructed on sloping ground, the relatively rigid reinforced concrete retaining wall generally imposes higher bearing stress at the wall toe and may require piles for support. The alternative solution involving the use of the reinforced fill technique could be much more economical.

An example of an alternative structure form is shown in Figure 6(b). In a number of highway projects in Hong Kong, reinforced fill structures have been found to offer technical and economical benefits over the conventional concrete viaducts (Shi & Swann, 2001; Lam, et al, 2001). The major saving is due to the fact that viaducts are generally sensitive to differential settlement and are usually supported on piled foundations, whilst reinforced fill structures can accommodate differential settlements and do not require expensive foundation support.

When constructed on sloping terrain, reinforced fill embankments can be built with much steeper side slopes than conventional fill slopes, hence reducing land take and disturbance to the surrounding land as shown in Figure 6(c).

Tall reinforced fill structures are particularly economical when compared with conventional retaining wall construction. This is because the quantity of the structural elements (i.e. facing and reinforcement) forming a reinforced fill structure is significantly less than that required for a conventional concrete retaining wall. In the case of low height structures the



influence of the cost of the facing on the overall costs becomes dominant. With small structures, the material requirements for the facing may be of the same order as the material for a conventional structure. At low heights particular attention may be required to reduce the costs of the facing element in order to retain the economical benefit of a reinforced fill structure.

Formed of prefabricated elements, reinforced fill retaining walls can be erected at a much faster rate than the conventional cast in-situ concrete walls, which require the erection of formwork. In most cases, the speed of reinforced fill retaining wall construction is limited only by the rate at which the selected fill can be placed and compacted. Reduced construction time leads to further cost-savings.

Reinforced fill retaining walls can be designed to provide high aesthetic appeal and almost any architectural finish or form can be provided without compromising the design. Reinforced fill slopes are ideal features for vegetation and landscape treatment, and can blend into the surrounding natural environment.

### **2.2.2 Sustainable Development**

A powerful argument for the use of reinforced fill is that this form of construction can be shown to be compatible with the concept of sustainable development. The global increase in energy costs has led to an interest in energy calculations in construction. By studying the embodied energy (i.e. energy employed in producing and transporting materials and the energy consumed for construction) of earth retaining structure, it is possible to compare the energy efficiency of different designs.

Energy is only one of the ecological parameters needed to determine the overall effects (short-term, long-term and associated) of engineering works. Of growing importance are the problems created by scarcity of raw materials, the environmental problems created by pollution, both of the atmosphere as well as the land from mining and construction activities, the increase in manpower and transportation costs and the cost of maintenance. The choice of structural form to be used for any scheme influences all of these parameters. Determination of the complete costs to society of a structure may be attempted by studying the ecological parameters represented in the whole cycle necessary for its production, including:

- mining,
- raw materials,
- process industry,
- basic materials,
- product/construction industry,
- product/structure,
- maintenance,

- waste, and
- recycling.

In practical terms, the ecological parameters associated with a reinforced fill structure are:

- energy content of the materials forming the structure,
- quantity of process water required to manufacture the materials,
- despoiling of land necessary to produce the materials,
- pollution caused during manufacture and construction,
- labour costs for material manufacture, transport, construction and maintenance, and
- demolition requirements.

Figure 7 shows the ecological parameter values for a 6 m prototype reinforced fill retaining wall compared with an equivalent reinforced concrete cantilever retaining wall. Even though the latter was an optimised design developed using a recognised retaining wall computer program, the reinforced fill structure is significantly more efficient in ecological terms. As economic parameters have as their ultimate base ecological considerations, which are immune from commercial distortions, Figure 7 is a potent argument that reinforced fill structures are efficient and economical.

### **2.2.3 Limitations**

The reinforcing elements within the reinforced fill zone may affect the installation of utility services, particularly when the structure forms part of a highway or railway system. The locations of services should be carefully selected so that future maintenance works do not cause disruption or damage to the reinforcement, drainage systems or undermine the toe of the structure. Major services such as trunk water mains and buried drainage systems should be kept as practically remote as possible from reinforced fill structures.

Degradation of reinforcing elements will occur, and this has to be taken into account in the design. Particular caution is required where reinforced fill structures are situated in the vicinity of industrial or waste disposal sites, or areas from which leakage from the sewerage system may be anticipated. Groundwater and other fluids entering the fill can bring into the structure aggressive substances that can accelerate the degradation of all forms of reinforcement. Stray electric currents especially direct current can prove aggressive to steel reinforcement and precautionary measures should be considered at sites where there are electric railways, tramways and other sources of such currents.

Additional tolerance should be allowed for the long-term design strength of polymeric reinforcement in subtropical Hong Kong, where the combined effect of temperature and creep is more severe than in other temperate countries. In addition, polymeric reinforcement can be subjected to damage by fire or vandalism when used as a facing. Where a hard cover is not warranted the design needs to consider remedial measures to be undertaken in the event of damage.

Imported fill is usually very expensive and any reinforced fill solution that requires imported fill is likely to have a significant cost penalty; the use of local indigenous fill should always be considered. Relatively high quality fill materials may be required for tall structures to achieve stability and also to limit wall movement. Importing fill to remote areas may offset the economical advantages of reinforced fill structures or slopes. Other specific limitations/restrictions of the different types of reinforced fill systems are given in Table 1.

## **2.3 Types of Reinforced Fill Systems**

### **2.3.1 General**

Table 1 describes some of the reinforced fill systems currently available, together with the perceived advantages/disadvantages, applications and restrictions. A wide range of reinforced fill systems has been developed. They can be classified as either wholly generic or proprietary systems, or generic systems which contain proprietary elements.

The use of fill, deposited in layers to form a reinforced fill feature, results in settlements within the fill mass caused by compaction forces. These settlements result in the reinforcing elements positioned on discrete planes moving together as the layers of fill separating the planes of reinforcement are compressed. Reinforced fill systems have to be able to accommodate this internal deformation within the fill. Failure to accommodate the differential movement may result in loss of serviceability or instability.

### **2.3.2 Elemental System**

Reinforced fill structures constructed using facings formed from discrete concrete panels are used widely (Figure 8(a) and (b)). Settlement within the fill mass is accommodated by the facing panels closing up an amount equivalent to the internal settlement. This is made possible by the use of a compressible joint to produce a horizontal gap between each facing element, Figure 8(c). Typical closure of the horizontal joints of a 7 m high reinforced fill retaining wall reported by Findlay (1978), is of the order of 5 to 15 mm for facing panels of 1.5 m high.

The shape and form of the facing panel must be compatible with the construction procedure adopted, and reinforced concrete panels 1 to 4 m<sup>2</sup> in area and 140 to 250 mm thick are typical. Suitable sealing measures are required along both vertical and horizontal joints between the individual facing panels to prevent the loss of fines through the joint gaps (Figure 8(c) and (d)).

Horizontal movements of the facing depend upon compaction of the fill and are made up of two components, horizontal strain of the fill and tilt of the facing units. Tilt of the facing

panels may have a marked effect upon the final appearance of the structure. In the case of the incremental form of construction, each facing panel tilts and the pivot points are dependent upon the geometry of the facing panel. To correct the effects of tilt caused during compaction, the individual facing panels may be inclined backwards at a gradient between 1 in 20 and 1 in 40.

### **2.3.3 Full Height System**

The use of full height facings can be economical in low to medium height structures including bridge abutments. With this form of facing, differential settlement within the fill can be accommodated by permitting the reinforcing members to slide relative to the facing. Slideable attachments can be provided by the use of grooves, slots, vertical poles, dowels, lugs or bolts. However, slideable attachments may not be necessary for reinforcement (e.g. geogrids) which is sufficiently flexible to accommodate the differential settlement within the reinforced fill mass.

Where a full-height rigid facing is used, it is normally erected and propped before filling starts (Figure 9). The construction procedure is often referred to as "tilt up".

### **2.3.4 Wrap-around System**

The wrap-around system of reinforced fill construction is illustrated in Figure 10. Differential settlement within the reinforced mass is accommodated by the face of the structure closing up similar to a concertina. Some of the largest modern reinforced fill structures have been built using this approach. Using geosynthetic reinforcing materials, this form of construction is frequently adopted to form steep reinforced fill slopes.

It is important to control face distortion to produce an acceptable appearance with the wrap-around system. In the original concept of the system, Vidal (1966) used an elliptical metal facing of sufficient stiffness to limit face distortion. However, polymeric reinforcement (e.g. geogrids) is commonly used for the construction of wrap-around facing and face distortion is controlled by the provision of soil-filled bags or steel meshes as shown in Figure 10.

### **2.3.5 Segmental Block System**

The segmental block system is a hybrid system which combines conventional block walling with reinforced fill (Figure 11). Both steel and polymeric reinforcement can be used with this form of construction. Unlike the elemental system, the block units of a segmental block system are not separated by compressible horizontal joints. As this form of facing is relatively rigid, differential settlement between the facing blocks and the fill mass must be strictly controlled by the use of good backfill and good compaction. Flexible reinforcement could be used to accommodate the differential settlement between the facing blocks and the reinforced fill mass.

### **2.3.6 Anchored Earth System**

Anchored earth systems have developed from a combination of the techniques used in reinforced fill and soil anchoring. The system is identified by the use of reinforcement in the form of anchors, which can be used with elemental, full height or segmental block systems. Anchors can be more efficient than some conventional reinforcement used in reinforced fill construction. Figure 12 shows anchored earth methods originating from Austrian, United Kingdom and Japanese practitioners. The Austrian application involves polymeric strips connecting segmental blocks and semi-circular anchors. The United Kingdom anchor uses a reinforcing bar bent to produce a triangular anchor; pullout resistance is mobilised by friction along the straight portion of the steel element and by passive pressure mobilised at the triangular anchor. The Japanese application exploits the local passive resistance of small rectangular anchor plates located at the end of the reinforcement.

## **2.4 Selection of Systems**

The selection of an appropriate reinforced fill system needs to consider the nature, size and intended use of the proposed structure or slope. For example, some materials such as geogrids or geotextiles may be used as both facing and the reinforcement, although the appearance of the resulting structure may not be acceptable other than for temporary, industrial or military applications. Similarly, the influence of fill properties on the durability of reinforcing materials may not be important with temporary constructions but are critical with permanent structures. Table 1 provides information that may influence the selection of an efficient construction system.

Speed of construction is usually required to achieve economy. This may be achieved by the simplicity of the construction technique and the use of readily available materials, particularly the use of indigenous fill. The properties of the available fill can be an important factor to be considered when the reinforced fill system is selected, in particular the selection of the type of reinforcement materials.

## **2.5 Proprietary Aspects**

Certain reinforced fill systems and components are covered by patents, and contract documents should contain suitable clauses to ensure no unforeseen liabilities are incurred with respect to their use. Patent and client's indemnification are further discussed in Section 10.4.

The use of proprietary products is frequently restricted to specific applications and some proprietary components may not be suitable for use in systems other than the proprietary system itself.

### 3 Concepts and Principles of Reinforced Fill

#### 3.1 General

Reinforced fill structures are different to conventional earth retaining structures in that they utilise a different mechanism of support. Figure 13 provides a classification of the common earth retention systems based on the three categories of externally, internally and hybrid stabilised systems (O'Rourke & Jones, 1990).

As shown in Figure 13(a), the conventional gravity or cantilever retaining walls could be regarded as externally stabilised systems as the stabilising force is provided by an external structure acting against the unstable soil mass.

An internally stabilised system such as a reinforced fill structure or slope involves structural elements (i.e. reinforcement) installed within a fill mass and extending beyond the potential failure plane (Figure 13(b)). The function of the reinforcement is to interact with the fill to absorb the stresses and strains which would otherwise cause the unreinforced fill to fail. A facing is normally required, but its purpose is to prevent local ravelling and deterioration rather than to provide primary structural support.

Reinforced fill structures which combine the stabilising elements of both internally and externally support systems are termed hybrid structures. They include the improvement of gravity structures in the form of reinforced segmental block retaining walls and reinforced gabion structures (Figure 13(c)). Within a hybrid structure, the facing elements are required to share the total stabilising forces with the reinforcement.

#### 3.2 Mechanism of Reinforced Fill

##### 3.2.1 Load Transfer Mechanism

The stability of reinforced fill relies upon the mechanism of load transfer between the fill material and the reinforcement. When a load is applied to a reinforced fill feature, tensile strains can develop within the reinforced fill. If the reinforcement has an axial tensile stiffness greater than that of the fill material, then lateral movement of the fill will only occur if the fill can move relative to the reinforcement. Provided the surface of the reinforcement is sufficiently rough, movement of the fill relative to the reinforcement will generate shear stresses at the fill-reinforcement interface. These shear stresses induce tensile loads in the reinforcement which are redistributed back into the fill in the form of an internal confining stress which is additive to any externally applied confining stress. The net effect of this fill-reinforcement interaction is a reduction of deformation compared to the unreinforced fill.

As shown in Figure 14(a) the common forms of reinforcement to provide mechanical improvement to the fill include sheets, bars, strips, grids, wire meshes and anchors. The resisting forces generated by fill-reinforcement interaction include friction generated at the fill-reinforcement interface and bearing on the transverse elements of specific types of reinforcement (Figure 14(b) and (c)).

### 3.2.2 Shear Resistance

When a fill slope is loaded in shear it deforms and the contacts of fill particles realign to mobilise shearing resistance. The deformation produces both compressive and tensile strains in the fill. If the fill mass contains reinforcement and there is effective fill-reinforcement interaction, any deformation in the fill will result in forces being developed in the reinforcement. The forces developed will be either compressive or tensile depending upon whether the reinforcement is inclined in the direction of tensile or compressive strain. The mobilised reinforcement force acts to alter the equilibrium force in the fill, and its magnitude is only limited by fill-reinforcement interaction or the strength of the reinforcement.

The influence of reinforcement placed horizontally within a reinforced fill retaining wall or steep slope, in the direction of tensile strain, can be shown by comparing the unreinforced case with the reinforced condition (Figure 15). In Figure 15(a) the self-weight of the fill causes a disturbing shear force,  $P_s$ , to act on part of the shear surface. This is resisted by the available frictional resistance  $P'_n \tan \phi'$ . When the slope is reinforced, shear deformation in the fill will result in a tensile force being mobilised in the reinforcement,  $P_r$ , which provides an additional resistance to shear failure (Figure 15(b)). The tangential component of the reinforcement force,  $P_r \sin \theta$ , directly resists the disturbing force in the fill, and the normal component of the force,  $P_r \cos \theta$ , mobilises additional frictional shearing resistance,  $P_r \cos \theta \tan \phi'$ . This action can be reproduced in a shear box containing reinforcement aligned in the direction of tensile strain (Figure 15(c)).

## 3.3 Factors Affecting the Behaviour of Reinforced Fill

### 3.3.1 General

Major factors affecting the behaviour and performance of reinforced fill are addressed in the following sections. In addition, the external loading and environmental factors such as bridge deck loading, seismic events and the ambient temperature will influence the behaviour and performance of reinforced fill.

### 3.3.2 Strain Compatibility

Equilibrium in a reinforced fill structure is reached when the tensile strain in the reinforcement and that in the adjacent fill are compatible. The strain compatibility requirement can be visualised by comparing the mobilised shearing resistance of the fill with the mobilised reinforcement force (Figure 16(a) and (b)). The equilibrium position can be determined using a strain compatibility curve which is a plot of the mobilised shearing resistance in the fill and the corresponding available force from the reinforcement (Figure 16(c)).

In Figure 16(c), the strain compatibility curve is drawn for a propped wall construction. Initially both the fill and the reinforcement have zero tensile strain, with the fill in the at-rest ( $K_0$ ) condition (i.e. the required forces for equilibrium taken by the props are due to at-rest earth pressures, shown as point 'A' in Figure 16(c)). Releasing the props disturbs the initial equilibrium, consequently tensile strains develop in the fill and in the reinforcement. This strain allows another equilibrium condition to be established, shown as the intersection of the

required and available forces, point 'X' for relatively in-extensible reinforcement and point 'Y' for relatively extensible reinforcement in Figure 16(c).

Examination of 'X' and 'Y' shows that load in the relatively in-extensible reinforcement builds up rapidly and equilibrium occurs at a lower strain than that required to mobilise the peak shear strength of the fill. By contrast, the relatively extensible reinforcement strains more but mobilises a lower force that contributes to the equilibrium of the fill feature. Ductile reinforcement will allow larger strains to occur at ultimate limit state without the reinforcement suddenly rupturing, irrespective of the initial stiffness of the reinforcement. The benefit of the tensile strength available in a ductile reinforcement at large strain exists even after the peak strength of the fill has been reached (McGown et al, 1978).

### 3.3.3 Reinforcement Properties

(1) *Durability.* Common materials used for reinforcement of fill include steel and polymeric materials. Glass fibres are also used in some cases. The stability of reinforced fill retaining walls and slopes relies upon the integrity of the reinforcement throughout the life of the structure. The durability of the reinforcing elements is a primary consideration.

The durability of the reinforcement is influenced by the environment provided by the fill. The pH value, chloride ion content, total sulphate content, sulphate ion content, resistivity and redox potential can all influence the durability of steel reinforcement or connections. Polymeric reinforcement are less susceptible to electrochemical attack, but are more susceptible to construction damage, the influence of ultraviolet light (UV) and heavy metal ions on high density polyethylene (HDPE) and, in the case of polyester materials, hydrolysis (see Section 4.1.6).

(2) *Form.* Reinforcement can take many forms depending largely on the material employed. Common forms are sheets, bars, strips, grids and anchors (Figure 14(a)).

(3) *Surface properties.* The coefficient of friction against pullout,  $\mu_p$ , is a critical property: the higher the value of  $\mu_p$  the more efficient the reinforcement. During pullout of a strip reinforcement at wide spacing with roughed or ribbed surface, the surface irregularities will cause re-orientation of the soil particles around the reinforcement, resulting in an increase of normal stress if the fill is dense and dilatant. The rougher the surface irregularity, the higher degree of re-orientation of soil particles and the larger the normal stress. Thus an ideally rough bar or strip has significantly higher pullout resistance than a reinforcement with a smooth surface.

The surface of the reinforcement can be made rough by deforming it, using grooves, ribs or embossing a pattern. Roughened surfaces will tend towards the ideally rough condition depending on the depth and spacing of the deformity/irregularity relative to the grading and particle size of the fill.

For grid reinforcement, the surface properties have a minor influence on pullout resistance and resistance to direct sliding. The penetration of soil particles through the grid is a major contribution to pullout resistance. For geotextile reinforcement, the surface properties



have a major influence on pullout resistance and resistance to sliding.

(4) *Strength.* Reinforcement utilises its tensile strength to provide support to the fill. Reliability of its tensile strength is synonymous with robustness. Any sudden loss of strength due to rupture of the reinforcement would have the effect of suddenly reducing the shear strength of the reinforced fill to the shear strength of the fill. This could lead to sudden catastrophic collapse of the reinforced fill feature or excessive deformation. Hence, the reinforcement should have sufficient safety margin in terms of strength and ductility to guard against this brittle mode of failure.

(5) *Stiffness.* Longitudinal stiffness, the product of elastic modulus and the effective cross-sectional area of the reinforcement, has a marked influence on the performance of reinforced fill. The longitudinal stiffness of the reinforcement governs the deformability of the reinforced fill. An axially stiff (i.e. relatively in-extensible) reinforcement will take up relatively little strain before taking up load. By contrast, a relatively extensible reinforcement will exhibit relatively large strain to reach the equilibrium stress state.

(6) *Creep.* In the case of reinforcement which are prone to creep (e.g. polymeric reinforcement), creep results in the transfer of stress to the fill. For designs where reinforcement sustain long-term loading, the load-strain curve at the intended design life ( $t_d$ ) has to be determined. Creep strain allows another equilibrium condition to be established, shown as the intersection of the required and available forces, point 'Z' for the extensible reinforcement in Figure 16(c).

However, as strain compatibility usually occurs in the strain hardening part of the fill shearing resistance curve (Figure 16(c)), the influence of reinforcement creep is reduced and the anticipated creep deformation of the structure does not occur. This benign influence of strain hardening of fill is frequently ignored and the creep deformation of polymeric reinforced fill structures is consequently overestimated. The effects of creep on the long-term load-carrying capacity of polymeric based reinforcement are addressed in Section 4.1.7.

### 3.3.4 Reinforcement Distribution

(1) *Location.* In order to establish the most effective location for the reinforcement to be placed in a reinforced fill structure or slope, potential failure mechanisms and planes have to be established together with the associated strain fields. For optimum effect, reinforcement is positioned within the critical strain fields in the locations of greatest tensile strains. Figure 17(a) shows the potential slip planes in a cohesionless backfill of a flexible wall rotating about the toe away from the fill; the  $\alpha_t$  and  $\beta_c$  trajectories define the expected form of the tensile and compressive strain fields respectively, and show that the horizontal direction is the direction of principal tensile strain (Figure 17(b)). Thus, placing reinforcement within the tensile strain arc would be effective.

(2) *Orientation.* In a reinforced fill structure or slope, the reinforcement is laid horizontally; in vertically faced structures this often results in the reinforcement being orientated in a near optimum plane as it bisects the tensile strain arc (Figure 17(b)). In most cases orientating the reinforcement in a horizontal plane, which is mostly within the tensile strain arc, will produce near optimum conditions. Changing the orientation of the reinforcement will reduce its effectiveness, and if orientated in the direction of the principal compressive strain, the action of reinforcement changes from that of tensile strain reinforcement to compressive strain reinforcement.

The strain field for slopes is more complex than that of a vertical structure (Figure 17(c)). Orientating the reinforcement parallel with the  $\alpha_t$  and  $\beta_t$  trajectories would be the equivalent of placing the reinforcement in line with a rupture plane. If the interaction between the fill and the reinforcement was less than the shear strength of the fill alone, the effect would be to lubricate the rupture plane thereby weakening the fill.

(3) *Spacing.* Smith (1977) and Jewell (1980) have established from laboratory tests that the increase in strength of reinforced fill is not always directly proportional to the number of reinforcing elements in the system. The spacing between reinforcement layers affects the performance of the individual reinforcing members. Below certain spacing, interference occurs, with the consequence that as the spacing reduces the increase in shear strength of the reinforced fill provided by each reinforcing member is reduced. The vertical spacing ( $S_v$ ) of reinforcement is usually controlled by construction practice with reinforcement being located to coincide with fill lifts. Spacings of 250 to 800 mm are common with vertical faced structures, the closer spacing being at the base of structures. At these spacings the reinforcement is fully effective.

The density of reinforcement in reinforced fill slopes may not be high and wider spacing is possible. Field studies have shown that the vertical spacing ( $S_v$ ) of principal reinforcement should not exceed 1 to 1.5 m. Intermediate reinforcement is sometimes used to prevent local ravelling and deterioration of the slope face. With fine-grained fill, vertical reinforcement spacings in the order of 300 to 500 mm are commonly used.

### 3.3.5 Fill Properties

(1) *Particle size and grading.* The ideal particle size for reinforced fill is a well-graded granular material, providing every opportunity for long-term durability of the reinforcing elements, stability during construction, and good physiochemical properties. In the normal stress range associated with reinforced fill structures and slopes, well-graded granular fill materials behave elastically, and post-construction movements associated with internal yielding will not normally occur.

Fine-grained fill materials are poorly drained and difficult to compact when moisture content becomes high following heavy rainfall. Therefore, construction using fine-grained fill normally results in a slower construction rate. Fine-grained fill materials often exhibit elasto-plastic or plastic behaviour, thereby increasing the chance of post-construction movements. Problems of stability and serviceability can also result from the use of crushable fill materials.

A well-graded granular fill can be compacted to the required density and provides the most advantageous conditions to optimize the fill-reinforcement interaction. Poorly graded or gap-graded fill may lead to the conditions similar to those associated with fine-grained fills. Uniformly graded fill should be used with care for reinforced fill application, as good compaction may be difficult to achieve and fill-reinforcement interaction may be reduced.

In some cases the availability of good granular fill is limited and fine-grained fill materials are used in reinforced fill structures. In these cases drainage measures to relieve positive pore water pressures should be provided. This leads to the concept of combining the

functions of reinforcement and drainage. Great care has to be taken when combining the materials that provide the reinforcement and drainage function together, as the result can be to produce structures with in-built planes of weakness resulting from the build-up of positive pore water pressures adjacent to the reinforcement, Jones et al (1997). The use of reinforcement with integral drainage has been shown to ameliorate this problem, Kempton et al (2000).

Particle size and grading of suitable fill materials is given in Table A.1 of Appendix A. TYPE I fill material has more stringent grading requirements and is normally preferred for the construction of tall retaining structures. TYPE II fill is generally suitable for the construction of low to medium height reinforced fill structures and slopes. Most of the residual soils and saprolites derived from in-situ weathering of granitic and volcanic rocks of Hong Kong fall within the grading limits of the TYPE II fill.

(2) *Index properties.* Index properties of suitable fill materials is given in Table A.1 of Appendix A. The plasticity requirements are prescribed to ensure that the fill has good construction and drainage characteristics.

### 3.3.6 Fill State

(1) *Density.* The density of a fill has an effect on the stress-strain relationship of the material. The density of fill is controlled by the degree of compaction achieved during construction. Poor compaction will reduce dilatancy of the fill and hence the shear strength. The effect of a dilating fill on the normal stress of a reinforcing element can be significant, although the increase in normal stress may reduce rapidly with increasing shear strain.

(2) *Overburden.* Overburden pressure influences the pullout resistance of reinforcement. Based on the test data from Schlosser & Elias (1978), the coefficient of friction against pullout for both smooth and ribbed steel strips decreases with increased overburden pressure. This is consistent with the general observation that the peak angle of shearing stress,  $\phi'_p$ , of a granular fill decreases with increase in normal stress. Tests to determine the angle of shearing resistance of the fill should be conducted at stress levels compatible with the maximum overburden pressure, as this will provide probably conservative results.

(3) *State of stress.* The quantity and stiffness of the reinforcement has an influence on the distribution of stress within a reinforced fill structure. With in-extensible reinforcement, the strain mobilised in the reinforcement and the equilibrium state of stress within the fill under working conditions corresponds to the at-rest ( $K_0$ ) condition. However, as the stresses within a granular fill increase (i.e. with increasing depth), the void ratio of the fill decreases, the shear strength of the fill increases and the strain in the fill required to develop the active ( $K_a$ ) condition reduces. As the reinforcement strain the active condition develops at the threshold strain beyond which shearing resistance will increase. Thus the state of stress within a reinforced structure will be different with increasing depth of fill and with different quantities and types of reinforcement.

At the top of a vertically faced reinforced fill structure reinforced with relatively in-extensible reinforcement such as steel, the stress state under working conditions will approach the at-rest condition,  $K_0$ ; lower down, the active condition,  $K_a$  will prevail. This has

been found in practice and conforms to the normal state of stress behind conventional retaining walls (Sims & Jones, 1974; Jones & Sims, 1975). When a structure is reinforced with relatively extensible reinforcement such as polymeric reinforcement, the strain in the equilibrium condition may correspond to the  $K_a$  condition throughout the structure. This state of stress behind reinforced fill retaining walls has been confirmed by measurements of various full scale reinforced fill walls under working conditions (Jones, 1978, 1979), McGown et al (1978), Jones et al (1990).

(4) *Temperature.* The properties of some reinforcement, particularly those made from polymeric materials, are temperature dependent. The long-term strength of some polymeric materials decreases with increase in temperature. Material tests undertaken in temperate climates may not be relevant to the conditions occurring in the subtropical climates of Hong Kong. The effects of temperature on the long-term load-carrying capacity of polymeric based reinforcement are addressed in Section 4.1.8.

### 3.3.7 Construction

(1) *Construction techniques.* Specific techniques have been developed to aid the construction of reinforced fill structures and slopes. These techniques can predetermine the use of certain materials, reinforcement forms, fill densities and construction geometries. Some construction systems are associated with proprietary products, covering facing units and reinforcement.

The facing of reinforced fill structures can be designed to move laterally a small distance after construction by having or generating some degree of slackness at the reinforcement to facing connection. The lateral earth pressure acting on the facing can then be reduced to the active ( $K_a$ ) condition. This hypothesis has been confirmed by Naylor (1978) using mathematical modelling, in laboratory studies by McGown et al (1978) and in the field by Jones et al (1990).

(2) *Compaction of fill.* The use of modern compaction plant generates significant residual lateral pressures which suggest that at-rest ( $K_o$ ) pressures predominate in many compacted fill materials. This condition has been confirmed in the case of earth pressures acting against retaining walls and bridge abutments, as well as in some reinforced fill structures.

The action of reinforcing members in the fill during compaction will be to resist the shear strain in the fill caused by the plant. Tensile stresses will develop in the reinforcement proportional to the residual lateral pressure acting normal to the face of the wall. The presence of the reinforcement in the fill raises the threshold for the residual lateral pressure which can be generated in the fill. Compaction of the fill using large plant close to the facing can result in distortion of the facing alignment (see Section 11.2.7) and should not be allowed.

(3) *Handling.* The materials forming a reinforced fill structure need to be handled with care. Damage to reinforcement can occur if proper construction practices are not followed. In particular, care must be taken to ensure that compaction plant is not permitted to run directly on reinforcement, and reinforcement must be handled and stored in accordance with the

manufacturer's requirements (see Section 11.2.6).

**3.3.8 Foundation**

Reinforced fill structures and slopes can be constructed on relatively weak foundations. However the nature and mode of settlement will be dictated by the foundation condition and the geometry of the structure (Jones, 1996). Reinforced fill walls often settle backwards when constructed on weak foundations (Figure 18(a)). The rotational behaviour of the reinforced fill mass in these circumstances is similar to that experienced by bridge abutments built on soft ground (Nicu et al, 1970).

Reinforced fill walls constructed on sloping rock foundations are frequently designed as stepped walls (Figure 18(b)). Consideration needs to be given to the possibility of fill arching at the base of the structure associated with the geometry of the steps in the foundation profile. Guidance on the dimensions of base width and height of step is provided in Section 7.14.

**3.4 Interaction between Fill and Reinforcement**

**3.4.1 General**

Interaction between the reinforcement and the fill determines the tensile strain for force equilibrium in any reinforced fill structure. Equilibrium breaks down if the reinforcement fails in tension or if the interaction between the reinforcement and the fill breaks down. There are two limiting modes of action of the latter (Figure 19(a) and (b)):

- (a) Pullout, where reinforcement pulls out of the fill after the maximum available pullout resistance has been mobilised.
- (b) Direct sliding, where a block of fill slides over the reinforcement.

**3.4.2 Pullout Resistance**

(1) *General.* The ultimate pullout resistance,  $P_{up}$ , of the reinforcement is given by:

$$P_{up} = 2\mu_p \sigma'_n L_e b \dots\dots\dots(3.1)$$

and

$$\mu_p = \alpha_p \tan \phi' \dots\dots\dots(3.2)$$

where  $\mu_p$  = coefficient of friction against pullout  
 $\alpha_p$  = pullout coefficient ( $\alpha_p \neq 1$ )  
 $\phi'$  = angle of shearing resistance of the fill under effective stress conditions  
 $\sigma'_n$  = effective normal stress at the fill-reinforcement interface

- $L_e$  = embedment length behind the failure surface, Figure 19(a)  
 $b$  = width of the reinforcement  
 $2 L_e b$  = the total surface area of the reinforcement in the resistant zone behind the failure surface

(2) *Grid reinforcement.* The definitions of the typical grid reinforcement dimensions are presented in Figure 20. The coefficient of friction against pullout,  $\mu_p$  can be obtained from shear box and pullout tests performed using the backfill selected for the project. Where good data are not available,  $\mu_p$  can be derived using analytical procedures.

In grid reinforcement, there are two main mechanisms of interaction between reinforcing elements and fill, which are illustrated in Figure 14(b) and (c):

- (a) frictional resistance mobilised between fill and plane surfaces of reinforcement, and
- (b) passive resistance mobilised by the transverse members of reinforcement.

The shape of the transverse elements of grids and anchors influences pullout resistance. Transverse members with a rectangular cross-section provide greater resistance to pullout than members with a circular cross-section. A conservative, general equation for the pullout coefficient,  $\alpha_p$  of the grid reinforcement is presented in Figure 20. The general equation can be used to give an estimate of the pullout coefficient of the generic forms of reinforcement. For the proprietary polymeric reinforcement, the appropriate design values stipulated in the reinforced fill product design data sheets (see Section 6.10) should be adopted for design.

[Amd GG6/01/2022]

(3) *Sheet and strip reinforcement.* For sheet and strip reinforcement, the pullout coefficient  $\alpha_p$  can be expressed as:

$$\alpha_p = \frac{\tan \delta_s}{\tan \phi'} \succ 1 \dots\dots\dots (3.3)$$

where  $\delta_s$  = skin friction angle for fill shearing over the reinforcement

(4) *Anchor reinforcement.* Reinforcement formed as anchors provides pullout resistance through frictional resistance of the anchor shaft and passive resistance acting against the anchor head.

General equations for the determination of allowable pullout resistance of a triangular anchor and a plate anchor are presented in Figure 21.

(5) *Pullout testing.* The coefficient of friction against pullout for finite or narrow width reinforcement and large aperture grids (i.e., strips, bars and steel grid/mesh reinforcement) and anchors can be determined from pullout tests (Figure 19(c)). Care is required as pullout tests results can be influenced by the conditions of the test, in particular frictional stresses on the front face of the pullout box must be eliminated (Palmeira & Milligan, 1989). The interpretation of the test

results should also take into account the effect of density of the fill achieved in the tests, the variability of the fill material and any extensibility of the reinforcement. For continuous sheet reinforcement (i.e. geotextile or geogrids), the interaction mechanism is similar to direct sliding, and the coefficient of friction against pullout, may be determined from modified direct shear box tests (see Section 3.4.3).

**3.4.3 Direct Sliding Resistance**

(1) *General.* The resistance to direct sliding of a fill over a layer of reinforcement depends on:

- (a) shear resistance between the fill and the planar surfaces of the reinforcement, and
- (b) fill-to-fill or fill-to-soil shear resistance through the apertures of grid reinforcement or closed-loop (e.g. triangular) anchors.

The ultimate direct sliding resistance,  $P_{uds}$ , of the reinforcement is given by:

$$P_{uds} = \mu_{ds} \sigma'_n L_i b \dots\dots\dots (3.4)$$

where  $\mu_{ds}$  = coefficient of friction against direct sliding  
 $\sigma'_n$  = effective normal stress at the fill-reinforcement interface  
 $L_i$  = length of the reinforcement  
 $b$  = width of the reinforcement

$\mu_{ds}$  can be obtained from direct sliding tests performed using the backfill selected for the project. Alternatively,  $\mu_{ds}$  can be expressed in terms of a direct sliding coefficient,  $\alpha_{ds}$  ( $\alpha_{ds} \geq 1$ ) such that:

$$\mu_{ds} = \alpha_{ds} \tan \phi' \dots\dots\dots (3.5)$$

where  $\phi'$  = angle of shearing resistance of the fill under effective stress conditions

(2) *Grid reinforcement.* In the case of grid reinforcement, direct sliding resistance depends on the shearing between the fill and the planar surfaces of the reinforcement and the fill-to-fill shear through the apertures of grid reinforcement. The direct sliding coefficient,  $\alpha_{ds}$ , can be expressed as:

$$\alpha_{ds} = \bar{a}_s \frac{\tan \delta_s}{\tan \phi'} + (1 - \bar{a}_s) \geq 1 \dots\dots\dots (3.6)$$

where  $\bar{a}_s$  = fraction of planar surface area of the reinforcement that is solid  
 $\delta_s$  = skin friction angle for fill shearing over the reinforcement

(3) *Sheet and strip reinforcement.* For sheet and strip reinforcement  $\bar{a}_s = 1$ , hence:

$$\alpha_{ds} = \frac{\tan \delta_s}{\tan \phi'} \not\geq 1 \dots\dots\dots(3.7)$$

(4) *Direct sliding testing.* The value of the coefficient of friction against direct sliding for continuous sheet reinforcement (i.e. geotextiles or geogrids) can be determined from modified direct shear tests (Figure 19(d) and (e)). For geotextile reinforcement where direct sliding occurs over the full plan area of contact, the test will be carried out on one side of the test sample (Figure 19(d)). In the case of grid reinforcement, direct sliding is generated both by fill sliding over fill passing through the apertures in the grid as well as fill sliding over the geogrid material itself. Therefore, the coefficient of direct sliding needs to be tested with fill placed on both sides of the reinforcement (Figure 19(e)).



## 4 Construction Materials

### 4.1 Reinforcement

#### 4.1.1 General

Reinforcement may take the form of sheets, bars, strips, grids or anchors, Figure 14(a), which are capable of sustaining tensile loads and the effects of deformation developed in the fill.

The most common reinforcement are formed from metallic or polymeric materials. Steel has been used for many years in soil and the mechanics and rate of corrosion are reasonably well established. The long term behaviour of polymers is not as well established as steel although they have been used for approximately two decades. Where necessary guidance should be sought from specialists on the use and the behaviour of polymeric reinforcement under specific conditions and environments.

#### 4.1.2 Metallic Reinforcement

Metallic reinforcement are usually made from galvanised steel and formed as strips, grids or anchors. The strength properties of the common carbon steel elements for reinforced fill applications can be found in BS EN 10025-1 (BSI, 2004c), BS EN 10025-2 (BSI, 2019c) and BS 4449 (BSI, 2016a). The tensile strength of steel reinforcement used in permanent works should be tested in accordance with BS EN ISO 6892-1 (BSI, 2019d). [Amd GG6/01/2017]  
[Amd GG6/01/2022]

#### 4.1.3 Polymeric Reinforcement

Polymeric reinforcement are commonly manufactured from polyester fibres and high density polyethylene (HDPE) grids. Polymeric grids can be manufactured from drawn polymer sheets containing holes or formed from woven/knitted or solid structural polymeric elements (e.g. polymeric strips/bars) welded or knitted together (Figure 23(a)). The tensile strength of polymeric reinforcement used in permanent works should be tested in accordance with BS EN ISO 10319 (BSI, 2015). [Amd GG6/01/2017]  
[Amd GG6/01/2022]

Polymeric reinforcement can be in the form of geocomposites. In the context of reinforced fill, geocomposites generally consist of high strength fibres set within a polymer matrix or encased within a polymer skin. The fibres provide the tensile properties for the material while the matrix or skin provides the geometrical shape and protects the fibres from damage. The common types of composite polymeric reinforcement are in the form of bars and strips (Figure 23(b) and (c)).

The tensile strength and extension characteristics of polymeric reinforcement are a function of the tensile properties of the constituent materials and the geometrical arrangement of the elements. The stress-strain characteristics of a range of polymeric materials are shown in Figure 24(a). However, polymeric reinforcement are seldom manufactured from polyaramid

fibres because of cost. As shown in Figure 24(b), the geometrical structure of the geotextiles have a dominant effect on their stress-strain characteristics. Woven material or materials formed from linear fibres are therefore preferred to non-woven materials for reinforced fill applications.

#### **4.1.4 Durability**

The durability of reinforcing elements is an important consideration in the design of reinforced fill structures or slopes. The problem is compounded because degeneration of reinforcement occurs underground, which can be difficult to monitor. Areas of critical degeneration may not be apparent until a failure occurs. Moreover, the subsequent remedial works may be difficult and can be costly.

#### **4.1.5 Corrosion of Metallic Reinforcement**

(1) *General.* Corrosion of metals is an electrochemical process (King, 1978) and the rate of corrosion is determined by material composition, the geometry of the object, its relationship to the environment and, most importantly, the nature of the surrounding fill.

The importance of the form of corrosion depends on the function of the element subject to attack. In the case of reinforced fill structures, failure of the connections between the facing and the reinforcement, or a banded attack across the reinforcing element, are the forms of corrosion which warrant designers' attention.

Fill materials present a complex environment to metallic reinforcement. Fill materials can be ranked from highly aggressive, requiring extensive precautions, to benign, requiring few precautions. Determination of the actual rate of corrosion is more difficult. The difficulty is compounded by the fact that the true nature of the fill material and the physical conditions within the reinforced fill feature can be determined only during or after construction. For permanent reinforced fill features, the engineering solution normally adopted is to select fill materials which are known to be non-aggressive in order to safeguard against unpredictable corrosion attack, thereby allowing suitable corrosion allowance to be made.

(2) *Factors influencing the corrosion of reinforcement.* In general, the corrosion of steel reinforcement in fill depends on the fill's physical and chemical characteristics. The physical characteristics are those that control the permeability of the fill to air and water. They include grain size, permeability and moisture content of the fill. Fine-grained fill materials (silts and clays) are potentially more aggressive than coarse-grained fill materials (sands and gravels) in which there is greater circulation of air and less water-retention capacity.

The chemical characteristics are those that determine the ability of the soil to act as an electrolyte for the development of local corrosion cells. They include alkalinity, acidity, concentrations of oxygen and dissolved salts, and organic matter and bacteria content. These factors affect electrical resistance, which is accepted as an important parameter for measuring corrosivity of a soil (Eyre & Lewis, 1987; King, 1978). Stray electric currents can seriously corrode steel reinforcing elements. Electrical connections for earthing must not be made to the

reinforcing element and earth rods must not be driven into the structure.

Water run-off from surfaces above the feature or leaking services in its vicinity can bring corrosive agents into the structure and, in many cases, this may be channelled towards the face and the connections. The corrosive material may tend to concentrate, resulting in an acceleration of corrosion.

(3) *Material compatibility.* All metallic components used in reinforced fill structures, i.e. reinforcing elements, connections and metal facings, should be of the same metal similarly treated (i.e. electrolytically compatible). Where this is not possible, effective electrical insulation must be provided.

(4) *Protection for steel reinforcement.* Steel reinforcement should be galvanised with a minimum average zinc coating of  $610 \text{ g/m}^2$  (equivalent thickness of 85 microns). For reinforced fill structures or slopes that are periodically submerged in water, the minimum average zinc coating should be  $1,000 \text{ g/m}^2$  (equivalent thickness of 140 microns).

In addition the sacrificial thickness to be allowed on the external and internal surfaces of galvanised steel reinforcement exposed to corrosion should comply with Table 2.

#### **4.1.6 Degradation of Polymeric Reinforcement**

(1) *General.* Modern polymeric reinforcement used in reinforced fill are composed of highly durable polymers. However, polymeric materials will degrade as a result of a number of different actions, including ultraviolet light, high energy radiation, oxidation, hydrolysis and other chemical reactions. Biological degradation is not considered an issue for polymeric reinforcement formed from high molecular weight polymers (Koerner et al, 1992).

The effects of temperature and stress will further complicate the assessment of polymer degradation (Grassie & Scott, 1985). It has been established that elevated temperature increases all the listed types of degradation in a predictable manner. Regarding stress, the rate of degradation is generally slower when the polymer fibres are under tension.

While the actions leading to degradation are complex, the overall impact on polymeric reinforcement is well established. Degradation of polymeric reinforcement is associated with chain scission, side chain breaking and cross linking (Grassie & Scott, 1985). Each of these actions causes the polymer to become progressively more brittle.

(2) *Effect of photo-oxidation.* Degradation due to oxidation can occur when the polymer is exposed to ultraviolet light (photo-oxidation). Ultraviolet light causes degradation by reaction with the covalent bonds of organic polymers causing yellowing and embrittlement. The influence of ultraviolet light on polymeric reinforcement can be eliminated by burying the reinforcement in the fill. However, in some reinforced fill applications the reinforcement are required to remain exposed to sunlight for certain periods, as in the case of wraparound-faced slopes and retaining walls. In these cases the reinforcement must be adequately resistant to the effects of UV light exposure.

Polyester has a good resistant to UV light. Polyethylene and polypropylene are less UV resistant than polyester. It is normal practice to provide a UV stabiliser into the polyethylene and polypropylene during the manufacturing process.

Two types of UV stabilisers are used for polyethylene and polypropylene, namely passive and active stabilisers. Passive stabilisers work by shielding the polymer molecules from UV radiation. The most common passive stabiliser is carbon black which has been shown to be an effective barrier for UV absorbed by polyethylene. The carbon black type and the dispersion characteristics are crucial to performance. In order to ensure extended UV protection, the carbon black must be of the channel type with a particle size of less than or equal to 20 nanometres ( $20 \times 10^{-9}$  m). A minimum concentration of 2% is normally required and it must be well dispersed. The result of the addition of carbon is to render the polymer black in colour.

Carbon black stabilisers are often used in conjunction with active stabilisers (e.g. hindered amines) which absorb the high UV radiation energy and release lower non-destructive energy. In converting the high energy UV radiation into low energy, the active stabiliser is consumed and hence the UV resistance life of the stabilised polymer depends upon the quantity of stabiliser originally added during the manufacturing process.

(3) *Effect of thermo-oxidation.* Degradation due to oxidation can occur when the polymer is exposed to heat (thermo-oxidation). Thermo-oxidation is not considered a problem with polyester but can have an effect on polyethylene and polypropylene.

Controlling the oxidation of polyethylene is a well developed science supported by long-term experience and a range of applications in the telecommunications cable insulation field. Antioxidants are added to the polymer to prevent oxidation during processing and use. Antioxidant packages calculated to provide over 250 years of life have been designed for specific polypropylene geotextiles (Wisse et al, 1990). In addition to the use of antioxidants, changing the molecular structure through orientation inhibits degradation. In the case of high density polyethylene (HDPE) geogrids, the degree of orientation acquired in the manufacturing process has been shown to provide significant resistance to oxidation.

(4) *Effect of hydrolysis.* Hydrolysis occurs when water molecules react with polymer molecules, resulting in chain scission, reduced molecular weight and strength loss. Polyester is the only polymeric reinforcement susceptible to hydrolysis. Hydrolysis is a slow reaction influenced by humidity, polyester structure, temperature, external catalysts and externally applied loads (Jailoux & Anderson, 1996).

Water must be present for hydrolysis to proceed, and the rate of hydrolysis increases with the relative humidity. The molecular weight of polyester affects the rate of hydrolysis. The advances in polyester manufacturing since 1940s have enabled heavier molecular weight polyesters to be produced with a consequent increase in resistance to hydrolysis. High molecular weight polyesters (average molecular  $M_n > 30000$ ) should be used for technically demanding applications such as reinforced fill materials.

Chemical agents can act as catalysts in the hydrolysis reaction. In an acid environment ( $\text{pH} < 2$ ), hydrogen ions ( $\text{H}^+$ ) increase the reaction rate. In an alkaline environment, the

presence of hydroxide ions ( $\text{OH}^-$ ) can have a detrimental and destructive effect when polyester fibres are directly exposed over long periods of time at  $\text{pH} > 11$ . Thus direct exposure of polyester fibres to environments such as curing concrete or calcium hydroxide initiates hydrolysis and reflects poor practice.

To protect polyesters from highly alkaline environments, robust coating of polyethylene (PE) or PVC is normally used. Both of these coatings ensure that, although water vapour can migrate through the casing, the PE or PVC acts as a barrier to the migration of inorganic ions. Thus the environment inside the casing remains neutral. If the barrier is punctured during installation protection can be lost.

#### **4.1.7 Creep and Stress Rupture of Polymeric Reinforcement**

For many polymeric-based materials, ambient operating temperatures coincide with their visco-elastic phase, thus creep becomes a significant consideration in assessing their long-term load-carrying capacity. Creep is the increase in extension of a material under a constantly applied load. Depending on the temperature and the level of load, polymeric reinforcement may continue to creep, and it may break after a certain time (i.e. stress rupture). The stress-strain-time characteristics (at constant temperature) of polymeric reinforcement can be visualized in the form of creep curves. The creep curves of most practical use are the stress-rupture curves, the isochronous creep curves and the creep coefficient curves (Figure 25).

The stress-rupture curves are used to predict the lifetime over which the polymeric reinforcement can carry a specific load. The stress-rupture curves for the various forms of polymeric reinforcement are shown in Figure 25(a).

The isochronous creep curves are used to estimate both the total extension and the creep extension of the polymeric reinforcement over different design lives and stress levels. Figure 25(b) shows a typical isochronous creep curves for a high modulus polyester strip. The shape of the curve indicates that there is little change in the load-extension curve with time for load levels below 40 % of the short-term tensile strength.

Creep coefficients curves provide a convenient means of comparing the rate of creep of different polymeric materials. Figure 25(c) shows the distribution of creep coefficients for various polymeric reinforcing materials. It can be seen that the creep coefficient increases for increasing applied load for polymers although processing techniques can alter significantly the rate of creep of a particular polymer.

#### **4.1.8 Temperature Effects**

As temperature affects the rate of creep and the stress-rupture characteristics of many polymeric reinforcement, this should be taken into account if design creep data is obtained at temperatures which are different from that occurring in service. Where creep data has been derived at higher ambient temperatures than those expected in service, conservative predictions would result if the data were used in the calculation of long-term design strength and extensions. Alternatively, if the creep data has been derived at lower ambient temperatures than those

expected in service, unsafe predictions may result. In the majority of tests for creep a test temperature of 20°C to 23°C has become the industrial standard.

The temperature experienced by the reinforcement throughout its embedment length changes with the seasons. In Hong Kong, the difference in temperature experienced by the reinforcement throughout the year can be in excess of 15°C. The majority of the temperature differential occurs in the first 0.5 m behind the wall face. Although the transient maximum soil temperature immediately behind the wall face could reach 35°C, the mean soil temperature beyond 0.5 m from the wall face is approximately 26°C (Hong Kong Observatory, 2002). In order to take into account the non-linear creep behaviour of polymeric reinforcement and the development of maximum tension in the reinforcement near the wall face, a design temperature of 30°C that is intermediate between the average soil temperature and the transient maximum soil temperature is recommended.

#### **4.1.9 Construction Damage**

The durability of reinforcing materials is also affected by physical damage or wear, such as damage due to site handling. Polymeric reinforcement can be damaged by tracked vehicles or by fill materials containing large angular particles, as can the protective coatings of metallic reinforcement. If the level of damage is not known, site damage tests should be conducted. The purpose of the site damage test is to subject the reinforcement to the environmental and construction conditions associated with the structure, and to measure the influence on the characteristic strength of the reinforcement. Reduced material strength is then used in design.

Polymeric reinforcement are generally more sensitive to construction damage. The effect of construction damage on polymeric reinforcement is to reduce the tensile strength but the deformation modulus (stiffness) is normally not affected. The amount of construction damage is dependent upon the nature of the reinforcement, the type of fill used and the compacting effort. The effects of construction damage to the tensile strength of polymeric reinforcement is considered in design by the use of partial factors applied to the tensile strength of the as-manufactured material (see Section 6.5.3(3)). The partial factor is determined by recovering the reinforcement from test sites and comparing the tensile properties with those of the pre-installed material. A site damage test for any form of reinforcement used in reinforced fill applications is detailed in BS 8006-1 (BSI, 2010). [Amd GG6/01/2017]

#### **4.1.10 Connections**

All connections used in permanent works should be tested in accordance with BS EN ISO 10321 (BSI, 2008b) for polymeric reinforcement and BS EN ISO 6892-1 (BSI, 2019d) for steel reinforcement. [Amd GG6/01/2017]

[Amd GG6/01/2022]

Connections should be formed to have the highest mechanical and durability efficiency possible relative to the performance characteristic of the parent material(s). Test methods used to assess connections should correspond closely to the procedures used when determining the properties of the parent materials.

Connections in geotextiles should normally be sewn where load transference is required (Figure 26). For polymeric grid reinforcement a bodkin connection may be used whereby two overlapping sections of grid are coupled together using a bar (steel or polymeric) passing through the aperture of the grid (Figure 26). When using bodkin connection care should be taken to ensure that:

- (a) bodkin connection has sufficient cross-sectional area and strength to avoid excessive deformation,
- (b) the size of bodkin connection is not too large so as to distort the parent material causing stress concentrations, and
- (c) slack from the bodkin connection is eliminated.

## 4.2 Facings and Connections

### 4.2.1 General

Facings can be formed as hard or soft facings. The selection of facing system depends on the nature and use of the proposed structure (see Section 2.4).

Depending on the material to be used, the strength of the facing and connection materials should be obtained from the relevant standards, e.g. BS EN 206 (BSI, 2021a), BS EN 1992-1-1 (BSI, 2004a) or BD (2020) for reinforced concrete, and BS EN 10025-1 (BSI, 2004c), BS EN 10025-2 (BSI, 2019c) or BD (2021) for steel. Where the structure is part of a private development, the requirements of the Buildings Ordinance (Laws of Hong Kong, CAP 123) must be complied with.

[Amd GG6/01/2017]

[Amd GG6/01/2022]

### 4.2.2 Hard Facings

(1) *Reinforced concrete.* Facings formed from reinforced concrete should be durable. Where sulphates are present in the backfill, subsoil or groundwater, reference may be made to BS EN 206 (BSI, 2021a), BS 8500-1 (BSI, 2019a), and BS 8500-2 (BSI, 2019b) for guidance on the selection of cement type and mix proportions to ensure durability.

[Amd GG6/01/2017]

[Amd GG6/01/2022]

Steel reinforcement should comply with relevant material standards set in Hong Kong. Adequate cover should be provided to the reinforcement, especially those surfaces in contact with the fill.

(2) *Segmental block.* The segmental block units are usually produced using machine moulded methods and are either dry cast or wet cast.

Segmental block units may be cast with positive mechanical interlocks in the form of shear keys or leading/trailing edges. Alternatively, interlock between layers may be developed by flat frictional interfaces that may include mechanical connectors such as shear pins, clips or wedges. The purposes of the mechanical connectors are to facilitate block alignment and to

control wall face batter during construction. Connectors in the form of polymeric combs and locking bars which are inserted into special cast slots at the top of segmental blocks are used with some proprietary polymeric reinforcement.

Segmental blocks are usually constructed with a stepped face and a batter ranging typically between 7 and 12 degrees. Shear transfer between unit layers is developed primarily through shear keys and interface friction. At the top of segmental block walls normal pressure is low and shear resistance may best be developed by mechanical connectors. For new systems, testing is recommended for the determination of the interface shear strength between the block units.

(3) *Pre-tensioned concrete.* Pre-tensioned concrete units can be used as facing elements in full height facing systems for reinforced fill (Table 1 and Figure 9). Full-height facings have a significant flexural rigidity and strength that inhibit potential failure mechanisms passing through the face of the wall. In addition, displacement of the facing during construction is reduced.

(4) *Joint fillers and sealants.* Joint fillers and sealants for hard facing should be composed of durable inert material resistant to the effects of air pollution.

### 4.2.3 Flexible Facings

(1) *Wrap-around facing.* This form of construction is illustrated in Figure 10. Wrap-around structures are constructed by folding an extended reinforcing element (geotextile or geogrid) through 180° to form the face and anchoring it back into the fill or to another element at a higher elevation. Fill is usually placed and compacted against external formwork.

Wrap-around facings permit free movement of the reinforcing elements thus allowing them to follow any settlement of the reinforced fill block. Wrap-around facings are normally used with steep slopes (i.e. slopes angle > 45°).

With open grid material used as wrap-around facing an internal liner in the form of an erosion control mat is frequently introduced in order to stop loss of fines.

(2) *Gabion facing.* Gabion facings are used to construct hybrid reinforced fill structures (Figure 13(c)). Gabion baskets can be formed from wire mesh or polymeric grid materials. Polymeric gabions are susceptible to attack by fire and ultraviolet light and are not usually used in permanent structures unless they can be properly protected.

Steel wire mesh gabions can be formed from continuous hexagonal woven material or welded mesh.

### 4.2.4 Facing Connections

Fasteners are used to make connections between the reinforcement and the facing and between facing elements. They take the form of dowels, rods, hexagon headed screws, bolts



and nuts. The material used to form the fastener should be compatible with the reinforcement material and the design life of the structure. Fasteners may be formed from the following materials:

- (a) galvanised or coated steel,
- (b) stainless steel, and
- (c) polymers.

In segmental block wall, connection between reinforcement and block units is normally developed through shear keys and interface friction. However, the frictional component may become ineffective if the horizontal joints between units open up as a result of differential settlement and arching, or seismic effects.

Polyethylene geogrid reinforcement may be structurally connected to precast concrete facing panels by casting a tab of the geogrid into the panel and connecting to the full length of the geogrid with a bodkin connection, as illustrated in Figure 26. Uncoated woven polyester geogrids and geotextiles should not be cast into concrete for connections, due to potential chemical degradation (see Section 6.9.3). Connection between the woven polyester reinforcement and the facing panel may be made by wrapping the grid or geotextile round a bar (steel or polymeric) which passes through the aperture of inserts (steel or polymeric) cast into individual facing units.

### **4.3 Fill Materials**

Reinforced fill retaining walls and bridge abutments are usually designed to use fill material of such a quality that will allow for easy and rapid construction. Similar considerations apply to the use of fill in reinforced slopes. Fill may be naturally occurring or processed materials.

### **4.4 Filter and Drainage Materials**

#### **4.4.1 Granular Filter and Drainage Materials**

Granular filter and drainage material should comprise durable inert material. The grading of granular filter and drainage materials should conform to the filter design criteria given in Geoguide 1 (GEO, 2020). [Amd GG6/01/2022]

The particle size distribution of in situ soil or backfill should be determined prior to construction and the filter should be designed using relevant criteria.

The level of compaction specified for granular filter and drainage materials should be compatible with the shear strength, stiffness and permeability of the materials required in design.

#### 4.4.2 Geotextile Filter Materials

Geotextile filters are often used in reinforced fill structures and slopes to control loss of fill from wrap-around facings and the joints of facing elements and also reduce the contamination of drainage materials from fine grained in situ soil or backfill. The design of geotextile filters should comply with the requirements given in Geoguide 1 (GEO, 2020).

[Amd GG6/01/2022]

Shear strength at the interface of the geotextile and the fill may be low. Where this is likely to be critical in design, direct shear tests should be carried out to determine the interface shear strength.

## 5 Investigation and Testing

### 5.1 General

This Chapter gives guidance on the investigation, sampling and testing relevant to the design and construction of reinforced fill structures and slopes. A model specification covering sampling and testing of fill materials and reinforcement is provided in Chapter 10.

### 5.2 Site Investigation

General guidance on site investigations is given in Geoguide 2: Guide to Site Investigation (GEO, 2017a). [Amd GG6/01/2022]

Site investigation for reinforced fill structures or slopes will normally proceed in stages as follows: desk study; site reconnaissance; collection of field data for design, including ground investigation, topographic and hydrographic survey and if necessary, follow-up investigation during construction. In addition, an investigation of the sources of suitable fill (see Section 5.3) is required.

The ground investigation should aim to establish the suitability of the site for reinforced fill construction and must include consideration of the adequacy of the foundation, the overall stability of the site with respect to the proposed works, the suitability of material on the site for fill, and the potential aggressiveness of the surrounding ground and groundwater. Particular caution should be exercised where the site is close to underground sewers, industrial areas, petrol filling stations, landfill sites, or waste disposal facilities.

Tests for pH, chloride content, water-soluble sulphate ( $\text{SO}_3$ ) and resistivity are usually conducted in reinforced fill applications particularly when metallic reinforcement is the preferred option. The measurement of organic content should be carried out for clayey soils where more than 15% of the soil particles pass the 63  $\mu\text{m}$  sieve. For clayey soils with an organic content in excess of the level specified in Table A.2 of Appendix A, then the measurement of either redox potential or microbial activity index should be carried out. The measurement of sulphide content is undertaken if the origin of the fill is likely to contain sulphides.

### 5.3 Investigation of Sources of Fill Materials

Fill is likely to come from one of the following sources:

- (a) crushed rock from quarries,
- (b) residual soils and saprolites derived from in-situ weathering of granitic and volcanic rocks, and
- (c) colluvial and alluvial sediments.

Stockpiles of crushed rock should be sampled to determine the grading envelope. Care should be taken to ensure that the sampling is representative and the results are reproducible because stockpiles formed by dumping from a conveyor will have a tendency for segregation.

As the properties of the in-situ weathered materials and the sediments could be extremely variable, sampling should be comprehensive to ensure confidence in the test results. The use of trial pits to obtain bulk samples is recommended.

The electrical and chemical properties of the fill material and the corresponding allowable limits specified in Table A.2 of Appendix A are intended to provide a relatively non-aggressive environment for hot-dip galvanized steel. Table A.1 of Appendix A gives the recommended particle size distribution, liquid limit and plasticity index of fill materials that are suitable for the construction of reinforced fill structures and slopes.

#### **5.4 Sampling and Testing of Fill Materials**

The source and properties of the fill may not be known during the design stage of a reinforced fill structure. In this case it is usual to assume conservative values for the geotechnical properties of the fill to be used. It should be demonstrated during the design stage or in the early stage of construction that the properties of the proposed source of fill comply with the geotechnical design parameters assumed in design and with the specification.

The designer should specify the type, number and frequency of the compliance tests. Flexibility should be allowed such that the testing frequency can be increased during construction if the engineering properties of the fill material are found to vary significantly. Regular checks on the properties of the fill should be specified by the designer.

Compliance testing of the proposed fill should normally include determination of the particle size distribution, Atterberg limits, moisture content, shear strength, electrochemical and compaction characteristics (as specified in Tables A.1 & A.2 of Appendix A). Proper compaction is important to the stability and long term durability of reinforced fill structures.

#### **5.5 Testing of Reinforcement and Connections**

Representative samples of the reinforcement and connection should be tested. The number of samples tested should reflect the size of the reinforced fill structure or slope. The recommended requirements on compliance testing of reinforcement and connections are provided in Clauses A.36 to A.39 of Appendix A.

For some polymeric reinforcement (e.g. high density polyethylene HDPE) carbon black is used to inhibit UV degradation. The recommended testing requirements for the determination of carbon black content and the dispersion of the carbon black are provided in Clauses A.43 to A.46 of Appendix A.

Laboratory shear or pullout tests should be undertaken to verify the design assumptions for the following:

- (a) fill-to-reinforcement interaction, and
- (b) facing unit-to-reinforcement interaction and interaction between facing units.

Testing for the verification of the design parameters relating interaction between fill and reinforcement should be undertaken using representative samples of the selected fill material. If the nature and properties of the fill change during construction, representative samples of additional verification tests (i.e. shear or pullout tests) should be considered.

The recommended testing requirements relating to interaction between fill and reinforcement; facing unit and reinforcement; and between the facing units are provided in Clauses A.58 to A.68 in Appendix A.

## 6 Design Considerations

### 6.1 General

This Chapter provides general guidance on the various technical aspects which need to be considered in the design of reinforced fill structures and slopes. The design considerations are summarised in Figure 27.

### 6.2 Design Situations

#### 6.2.1 General

The design situations to be considered should be sufficiently severe and varied so as to cover all possible conditions that may occur during construction and throughout the design life of the proposed reinforced fill structure or slope.

The following information is required to determine the various design situations:

- (a) user's functional requirements and service life of the reinforced fill structure or slope,
- (b) nature of the environment, together with the loading conditions within which the reinforced fill structure or slope is to be subjected to during construction and in service over its design life, including:
  - (i) geological profile and variations in soil and rock properties,
  - (ii) changes in surface water flow and groundwater levels, and pore water pressures,
  - (iii) presence of potentially aggressive groundwater or soils, including leakage from sewers and drains,
  - (iv) surcharge behind the structure or slope,
  - (v) effects of planned development in the vicinity,
  - (vi) effects of earthquake, and
  - (vii) protection of reinforcing elements against possible damage caused by excavation for installation and maintenance of utilities.
- (c) aspects of construction that are pertinent to the design, including:
  - (i) quality and nature of the available fill,
  - (ii) possible damage to reinforcement during construction,
  - (iii) construction tolerances and serviceability limits,
  - (iv) compaction stresses behind the wall facing, and
  - (v) material testing and performance monitoring.

Each design scenario should be clearly defined, together with the relevant types of loading.

Conceivable accidents should be considered during the design process and the reinforced fill structure or slope should be designed in such a way that it will not be damaged disproportionately or lose its stability under such accidental conditions. Particular consideration should be given to accidents which could result in inundation of the reinforced fill by large quantities of water, such as caused by bursting of water mains. The risk of inundation is usually best dealt with by prescriptive measures, e.g. re-routing or ducting of water-carrying services.

### 6.2.2 Design Life

The design life of a permanent reinforced fill feature should be taken as 120 years unless otherwise specified by the owner.

### 6.2.3 Loading Conditions

(1) *Surcharge loading.* The main loading of a reinforced fill structure or slope results from the self weight of the fill. Surcharge on top of and behind a reinforced fill structure or slope can be either permanent (e.g. loads due to the weight of a bridge deck or superimposed embankment) or temporary (e.g. loads due to traffic, construction plant or the storage of materials).

Guidance on surcharge loading is given in Chapter 7 of Geoguide 1 (GEO, 2020).

[Amd GG6/01/2022]

(2) *Seismic loading.* Hong Kong is situated in a region of low to moderate seismicity and seismic load is generally not critical for retaining wall design (Geoguide 1 (GEO, 2020)). Reinforced fill structures and slopes have been shown to be very resistant to seismic forces (Tateyama et al, 1995).

[Amd GG6/01/2022]

Guidance on seismic loading appropriate for the Hong Kong conditions is given in Section 7.4 of Geoguide 1 (GEO, 2020).

[Amd GG6/01/2022]

## 6.3 Selection of Reinforced Fill Systems

In the selection of a reinforced fill retaining wall or slope system, the following factors should be considered:

- (a) nature of the existing ground and groundwater conditions,
- (b) size of the reinforced fill structure and the amount of space available for construction,

- (c) availability of fill materials,
- (d) extent of ground movement acceptable during construction and in service, and the effect of movement of the retaining structure or slope on nearby structures and services,
- (e) construction issues including the time available for construction,
- (f) testing and maintenance requirements needed to ensure that the design life of the structure or slope is achieved, and
- (g) aesthetics of the facing of the retaining wall or slope.

Details of available reinforced fill systems and the method of construction are given in Section 2.3. Where several alternatives are suitable, an economic comparison should be made based on their initial construction and subsequent maintenance costs.

## **6.4 Limit States and Modes of Instability**

### **6.4.1 Limit States**

The philosophy followed in this Geoguide is to design against the occurrence of a limit state. For the purposes of reinforced fill design a limit state is deemed to be reached when one of the following occurs:

- (a) total or partial collapse,
- (b) deformation in excess of acceptable limits, and
- (c) other forms of distress or minor damage which render the structure unsightly, require unforeseen maintenance, or shorten the expected life of the structure.

The performance of reinforced fill structures and slopes are considered in accordance with the ultimate limit state and the serviceability limit state criteria. The ultimate limit state and the serviceability limit state are defined as:

*Ultimate limit state.* A state at which failure mechanisms can form in the ground or within the reinforced fill structure or slope, or when movement of the reinforced fill structure or slope leads to severe damage to its structural elements or in nearby structures or services.

*Serviceability limit state.* A state at which movements of the reinforced fill structure or slope affect its appearance or its efficient use or nearby structures or services which rely upon it.



The condition defined in (a) above is the ultimate limit state and (b) is the serviceability limit state and (c) can be considered for both ultimate and serviceability limit states depending on the user's functional requirements. The use of the limit state methodology permits various limit states to be considered separately in the design and their occurrence is either eliminated or is shown to be sufficiently unlikely.

## **6.4.2 Modes of Instability**

The modes of instability (i.e. failure mechanisms) relating to the external and internal ultimate limit states are illustrated in Figures 28 and 29 respectively. The modes of failure relating to the compound ultimate limit states are illustrated in Figure 30. The limit states relating to serviceability are shown in Figure 31.

Other modes of failure may be appropriate in certain circumstances and have to be checked accordingly, for example:

- (a) three-dimensional effects could influence the overall failure mechanism,
- (b) modes of failure could be governed by seismic or cyclic loading, and
- (c) complex modes of failure could be caused by excessive movement of the structure.

## **6.5 Factors of Safety**

### **6.5.1 General**

The reliability of reinforced fill design depends not only on the method of analysis, but also on the way in which factors of safety are defined, the reliability of the geotechnical model and the built quality required to be achieved. Therefore the minimum factors of safety recommended in this Geoguide should not be used out of context.

The minimum partial factors recommended for use in the design of reinforced fill structures and slopes are listed in Tables 3 and 6 to 8.

### **6.5.2 Overall Stability**

When designing against overall slope instability (Figure 28) the global-safety-factor approach recommended in the Geotechnical Manual for Slopes (GEO, 1984) should be followed.

### 6.5.3 Partial Factors

(1) *General.* The current approach to applying factors of safety for reinforced fill structures and slopes uses partial consequence factors, material factors and load factors. The partial factor format is appropriate to reinforced fill design where a range of materials may be used for structures of different design lives and where the consequence of failure depends upon the end use.

Design values of reinforcement parameters, geotechnical parameters and loading, as defined below, should be used directly in the design calculations:

$$R_D = \frac{R}{\gamma_n \gamma_m} \dots\dots\dots(6.1)$$

$$G_D = \frac{G}{\gamma_m} \dots\dots\dots(6.2)$$

$$F_D = \gamma_f F \dots\dots\dots(6.3)$$

where  $R_D$  = design value of reinforcement parameters, R  
 $G_D$  = design value of geotechnical parameters, G  
 $F_D$  = design value of loading, F  
 $\gamma_n, \gamma_m, \gamma_f$  = partial consequence factor, material factor and load factor respectively.

The geotechnical parameters include shear strength of the fill and the permeability of drainage materials. The reinforcement and facing unit parameters include tensile strength of the reinforcing elements, fill-to-reinforcement interaction, facing unit-to-unit and facing unit-to-reinforcement interaction.

(2) *Partial factors for consequence of internal failure.* In order to account for the consequence of internal failure, a partial consequence factor,  $\gamma_n$  is applied to the reinforcement parameters in accordance with Equation 6.1. As the application of increased (factored) external loads to a reinforced fill structure or slope is not always unfavourable due to the fact that increased stresses in a granular fill results in an enhanced shear strength, the application of  $\gamma_n$  to the reinforcement parameters is a more consistent approach to a margin of safety than if it was applied to the loads.

The values of  $\gamma_n$  for the different consequence categories are given in Table 3. Typical examples of failures relating to the consequence-to-life category and the economic consequence category are provided in Tables 4 and 5 respectively.

(3) *Partial factors for reinforcement.* The required minimum value of the partial material factor,  $\gamma_m$  for reinforcement should cover the effects of material variability, construction damage, environmental effects on material durability and other special factors including hydrolysis, creep and stress rupture that are related to polymeric reinforcement (Section 4.1). The minimum values of the partial material factor,  $\gamma_m$ , recommended for reinforcement are given in Table 6.

For polymeric reinforcement, the partial material factor,  $\gamma_m$  is given by:

$$\gamma_m = \gamma_d \cdot \gamma_{cr} \cdot \gamma_{cd} \dots\dots\dots (6.4)$$

where  $\gamma_d$  = partial factor on reinforcement to allow for durability  
 $\gamma_{cr}$  = partial factor on reinforcement to allow for creep  
 $\gamma_{cd}$  = partial factor on reinforcement to allow for construction damage

The partial factors  $\gamma_d$  and  $\gamma_{cr}$  on the reinforcement to allow for durability and creep respectively are not only governed by the design temperature but also the design life of the structure or slope. In the case of the accepted proprietary reinforcement in Hong Kong, the minimum values of  $\gamma_m$  can be found in the relevant reinforced fill product design data sheets issued by the Civil Engineering and Development Department of the Hong Kong SAR Government. [Amd GG6/01/2022]

(4) *Partial factors for fill materials.* “Compacted fill” refers to the fill, both reinforced (i.e. selected fill material) and unreinforced (i.e. suitable fill material), placed for the construction of the reinforced fill structure or slope.

The minimum value of partial material factor,  $\gamma_m$ , recommended for shear strength of fill is given in Table 6.

(5) *Partial factors for fill-to-reinforcement interaction.* There are two possible fill-to-reinforcement interaction mechanisms:

- (a) fill-to-reinforcement interaction where a potential failure surface crosses a layer of reinforcement. The fill-to-reinforcement interaction mechanism in this case is related to tensile and pull-out resistance (see Section 3.4.2), and
- (b) fill-to-reinforcement interaction where the potential failure surface coincides with a layer of reinforcement. The fill-to-reinforcement interaction mechanism in this case is related to sliding resistance (see Section 3.4.3).

The minimum values of the partial material factor,  $\gamma_m$ , recommended for pull-out resistance and for sliding resistance are given in Table 6.

(6) *Partial factors for facing units interaction.* In the design of reinforced segmental block retaining walls, stability checks are required to ensure the column of block units remains intact, hence, the available shear capacity at any unit-to-unit or unit-to-reinforcement interface level will have to be assessed. The minimum values of the partial material factor,  $\gamma_m$ , recommended for unit-to-unit and unit-to-reinforcement interaction are given in Table 6.

(7) *Partial load factors.* The minimum values of partial load factor,  $\gamma_f$  recommended for use in the design of reinforced fill structures and slopes are listed in Table 7.

The most adverse loads and load combinations likely to be applied to reinforced fill structures and slopes should be considered in design. Different load combinations are identified with different scenarios. The partial factors to be applied to each component of the different load combinations for reinforced fill retaining walls and bridge abutments are recommended in Table 8.

## 6.6 Design Strengths

### 6.6.1 Reinforcement

(1) *Steel reinforcement.* For steel reinforcement the design tensile strength,  $T_D$ , per unit width of reinforcement is given by:

$$T_D = \frac{a_r \sigma_t}{b \gamma_m \gamma_n} \dots\dots\dots(6.5)$$

- where
- $a_r$  = cross sectional area of the reinforcement minus potential corrosion losses
  - $\sigma_t$  = the ultimate tensile strength of steel
  - $b$  = width of the reinforcement
  - $\gamma_n$  = partial factor to account for consequence of internal failure (Table 3)
  - $\gamma_m$  = partial factor on tensile strength of reinforcement (Table 6)

For design, the selected value for  $\sigma_t$  should be the minimum ultimate tensile strength guaranteed by the manufacturer.

(2) *Polymeric reinforcement.* The design strength of polymeric reinforcement should be derived on the basis of the following principles:

- (a) During the life of the structure, the reinforcement should not fail in tension.
- (b) The deformation of the structure during its service life should comply with the user’s functional requirements. As a general guidance, the post-construction strain of the reinforcement should be limited to 1% for retaining walls and 0.5% for abutments.

Thus, the design tensile strength,  $T_D$ , per unit width of reinforcement is given by:

$$T_D = \frac{T_{ult}}{\gamma_m \gamma_n} \dots\dots\dots(6.6)$$

where  $T_{ult}$  = ultimate tensile strength per unit width of the polymeric reinforcement.

For design, the selected value for  $T_{ult}$  should be the characteristic short-term tensile strength guaranteed by the manufacturer.

**6.6.2 Fill Materials**

For good quality fill materials which satisfy the grading and plasticity requirements given in Table A.1 of Appendix A, it is generally sufficient to adopt a  $c' = 0$  soil strength model for design purposes. Such a model gives a conservative estimate of the shear strength of the backfill and is simple to apply in design. The design shear strength parameters,  $\phi'_{des}$ , can be determined from:

$$\phi'_{des} = \tan^{-1} \left( \frac{\tan \phi'}{\gamma_m} \right) \dots\dots\dots(6.7)$$

where  $\gamma_m$  = the partial material factor on the shear strength of fill, Table 6

**6.6.3 Fill-to-Reinforcement Interaction**

The design coefficients of interaction  $\mu_{pD}$  and  $\mu_{dsD}$  relating to pullout and direct sliding instabilities respectively are given by:

$$\mu_{pD} = \frac{\alpha_p \tan \phi'}{\gamma_m \gamma_n} \dots\dots\dots(6.8)$$

$$\mu_{dsD} = \frac{\alpha_{ds} \tan \phi'}{\gamma_m \gamma_n} \dots\dots\dots(6.9)$$

- where  $\mu_{pD}$  = design coefficient of interaction against pullout
- $\mu_{dsD}$  = design coefficient of interaction against direct sliding
- $\gamma_n$  = partial factor to account for consequence of internal failure, Table 3
- $\gamma_m$  = partial factor for fill-reinforcement interaction, Table 6
- $\alpha_{ds}$  = direct sliding coefficient
- $\alpha_p$  = pullout coefficient

In the case of the accepted proprietary reinforced fill products in Hong Kong, the partial factors  $\gamma_m$  are specified in the relevant reinforced fill product design data sheets issued by the Civil Engineering and Development Department of the Hong Kong SAR Government.

[Amd GG6/01/2022]

**6.6.4 Facing Units Interaction**

The stability of segmental block retaining wall facing depends on the shear capacity between block units and the resistance mobilised at the block-to-reinforcement interface. The ultimate shear capacity at any unit-to-unit or unit-to-reinforcement interface can be calculated using the following equation:

$$V_u = a_u + N_u \tan \lambda_u \dots\dots\dots(6.10)$$

where  $V_u$  = ultimate shear capacity per unit length of wall acting at the interface  
 $N_u$  = normal load per unit length acting at the interface  
 $a_u$  = ultimate adhesion at the unit-to-unit or unit-to-reinforcement interface  
 $\lambda_u$  = peak friction angle at the unit-to-unit or unit-to-reinforcement interface

The design coefficients  $a_{des}$  and  $\lambda_{des}$  for the design shear capacity at any unit-to-unit or unit-to-reinforcement interface can be determined from:

$$\lambda_{des} = \tan^{-1} \left( \frac{\tan \lambda_u}{\gamma_m \gamma_n} \right) \dots\dots\dots (6.11)$$

$$a_{des} = a_u / \gamma_m \gamma_n \dots\dots\dots (6.12)$$

where  $\gamma_n$  = partial factor for consequence of internal failure, Table 3  
 $\gamma_m$  = partial factor for interaction between facing units, Table 6

**6.6.5 Facing Elements**

The design strength of the facing elements should comply with the requirements of relevant structural codes and standards used in Hong Kong. Further advice on structural design is given in Section 4.3.5 of Geoguide 1(GEO, 2020). [Amd GG6/01/2022]

**6.7 Construction Tolerances and Serviceability Limits**

**6.7.1 General**

Reinforced fill structures or slopes deform during construction. Consideration should be given to providing the necessary construction tolerances to permit them to attain a stable configuration, and also to ensure that construction and post-construction movements are within acceptable limits.

Uniform settlement of a reinforced fill mass rarely presents problems; however, checks must be made to ensure the drainage systems, services and supported structures can accept the movements.

**6.7.2 Construction Tolerances**

The construction tolerances for reinforced fill walls and abutments are normally related to wall facings. Structures formed from elemental concrete panel, segmental block or wrap-around facings are constructed with one facing layer preceding the placement of a layer or layers of fill and reinforcement. In these systems construction tolerances are largely influenced by the compaction effort from the construction plant and the effect of the compaction process on the facing need to be closely monitored during construction. With full-height facings the wall panels may be erected and propped before the placement of the reinforcement and the fill.

Alignment of the facing is easy to achieve and maintain. Reinforced fill structures or slopes formed using wrap-around facings cannot usually be constructed to close tolerance.

Acceptable construction tolerances for the various reinforced fill facing-systems are specified in Table A.3 of Appendix A.

### 6.7.3 Settlement

(1) *General.* The effects of settlement must be considered in respect of:

- (a) distortion of the facing,
- (b) additional internal strains imposed on the reinforced fill mass,  
and
- (c) differential movements imposed on bridge decks or other structures supported by the reinforced fill structure.

(2) *Differential settlement.* The tolerance of reinforced fill facing systems to differential settlement along the line of the facing is shown in Table 9. Differential settlements normal to the face of the structure will result in rotation of the reinforced fill block. Backward rotations (into the fill) of 1:50 have been experienced in reinforced fill structures without any distress being experienced. However, consideration should be given to a differential settlement producing additional strain in the reinforcement and stresses on connections.

(3) *Internal compression.* Reinforced fill structures compress internally during placement and compaction of the fill layers, so the construction system and the construction tolerances must be able to accommodate these movements (see Section 2.3.1). Table 10 provides typical movement capacities of facing systems to cope with internal compression of the reinforced block.

## 6.8 Design Detailing, Construction Procedure and Logistics

The successful construction of a reinforced fill structure or slope depends upon a range of factors which can influence performance, durability and appearance. The provision of good drainage details is of critical importance to all reinforced fill construction but only in the case of permanent structures is the consideration of aesthetics considered to be important. Some factors are closely interrelated, in particular the fill and the reinforcement (see Section 3.4).

The difference between good and poor construction details can be subtle, and weaknesses and deficiencies may become apparent only during the construction phase or later during the life of the structure. The design detailing recommended in Sections 7.11.2 and 7.17, although not necessarily the best possible, have been shown to be efficient and effective in some conditions. In some cases the details represent a compromise between constructional practicality and durability criteria.

Reinforced fill structures encourage the use of non-conventional construction procedure. It is possible to streamline the construction procedure and eliminate some steps as illustrated in Figure 32.

The speed of construction must be catered for if the full potential of the use of reinforced fill structures is to be realized. Normally, this will cause little or no problem with the reinforcement materials, but the production and delivery rate of the facing units may cause problems, particularly if multiple use of a limited number of shutters is expected for economy.

Transport may cause difficulties and the choice of structural form and construction technique may depend ultimately on the ease and economy of moving constructional materials. As an example, the lightweight of the geosynthetics reinforcing materials, with their ability to be transported in rolls, makes them suitable for air-freight.

## **6.9 Protection of Reinforcement**

### **6.9.1 General**

The design should ensure that the reinforcement is not subjected to conditions which can result in damage or deterioration throughout the design life.

### **6.9.2 Metallic Reinforcement**

The durability of metallic reinforcement is primarily related to electrochemical corrosion. In general this is covered in the design by compliance with the requirements of Section 4.1.5. Situations that require special attention include:

- (a) Interference between reinforcement such as when reinforcement on the same level is positioned at right angles to produce corners in the structure. In this case the reinforcement should be separated vertically by a layer of fill greater than 100 mm in thickness, and
- (b) Stray electrical currents can increase corrosion rates of metallic material buried in fill. This concern should be addressed when reinforced fill structures are located close to electrified railways. Where stray electrical currents may occur, suitable precautions such as isolating the reinforcement from the stray currents or connecting all the reinforcement to a common electrical current should be considered.

### **6.9.3 Polymeric Reinforcement**

The durability of polymeric reinforcement can be influenced by exposure to ultra-violet light and intense heat for polyethylene and polypropylene products and the hydrolysis of



polyester (see Section 4.1.6). Design situations which expose non-coated woven polyester reinforcement to highly alkaline environments should be avoided. However, woven polyester reinforcement with damaged protective coating are also vulnerable to highly alkaline environments. A maximum period should be specified for which polymeric reinforcement can be exposed to sunlight after removal from its protective wrapping and before burial. This allowable maximum exposure period should be specified in the contract specification or drawings. If necessary detailed advice should be sought from the manufacturer prior to completing the design.

## **6.10 Prior Acceptance of Proprietary Reinforcement**

[Amd GG6/01/2022]

The facing units, reinforcing elements and connections used in reinforced fill structures and slopes often comprise proprietary products developed and supplied by specialist companies. Because of the variety of materials used, it is impractical to define standard properties and performance parameters which will cover all available products, as well as those which may become available in future. Also, from time to time, new materials for which no established standards exist will become available.

The Civil Engineering and Development Department of the Hong Kong SAR Government regulates different proprietary reinforcement used in permanent reinforced fill in Hong Kong through a product assessment and acceptance process, in order to ensure the safety of structures and slopes constructed with these materials. Reinforced fill product design data sheets, issued by the Civil Engineering and Development Department, specify suitable design strengths of different proprietary reinforcement and the conditions of use for the Hong Kong conditions.

[Amd GG6/01/2022]

## **6.11 Performance Monitoring**

The performance of reinforced fill structures and slopes may need to be monitored when the design uses new materials, unusual methods of construction or where movements could affect adjoining properties. The need for performance monitoring should take into account the factors listed below:

- (a) complexity of the ground conditions,
- (b) any innovative elements in the design,
- (c) complexity of the method and sequence of construction, and
- (d) need to improve knowledge of new materials or construction techniques.

Under the outlined factors, performance monitoring can be used to:

- (a) ensure that the feature is performing as designed,

- (b) modify construction procedures for economy,
- (c) enhance design knowledge and to provide a base reference for future design, and
- (d) provide insight into maintenance requirements, by long-term monitoring.

Guidance on the planning of monitoring, monitoring methods and data evaluation is given in Geoguide 1 (GEO, 2020). [Amd GG6/01/2022]

## 6.12 Maintenance and Urgent Repair

The performance of reinforced fill walls and slopes can be adversely affected by a range of environmental and human factors. Examples include:

- (a) unplanned vegetation growth that leads to adverse visual appearance,
- (b) blockage of the surface drainage system and sub-surface drainage outlets due to accumulation of debris from surface runoff or excessive growth of vegetation,
- (c) bursting of a water main resulting in inundation of the reinforced fill block,
- (d) scouring of the toe of the structure causing washout of backfill and dislodgement of facing units,
- (e) accidental loading such as vehicular impact that could lead to displacement of wall coping and facing units, and
- (f) fire or vandalism that leads to damage or deterioration of the non-structural or structural facing.

The conditions mentioned in (a) and (b) above can be rectified by regular maintenance. However, the conditions in (c), (d), (e) and (f) require urgent repair works to be carried out to ensure satisfactory performance of the feature. Designers should be aware of typical maintenance requirements and should consider these during the design stage.

Upon completion of construction of a reinforced fill structure, its associated drainage layers are generally sealed off. However, under special circumstances, such as excavation works in the vicinity of a reinforced fill structure, the associated drainage layers may be exposed giving rise to the possibility of excessive ingress of surface water. The maintenance manual of the reinforced fill structure should draw the attention of the maintenance agent to the need for ensuring adequate temporary drainage provisions and implementation of necessary precautionary and mitigation measures, to keep the water away from the structure and guard

against excessive ingress of water into the drainage layers under the circumstances.

[Amd GG6/01/2017]

Guidance on the maintenance of slopes and conventional retaining walls which is also applicable to reinforced fill features is given in Geoguide 5 (GEO, 2021).

[Amd GG6/01/2017]

[Amd GG6/01/2022]

### 6.13 Services

Utility services are frequently associated with reinforced fill construction, particularly when the structure or slope forms part of a highway or railway system. Specific arrangement should be made to accommodate services in the design. It is bad engineering practice to route water-carrying services (watermains, stormwater drains or sewage) close to the crest or through the body of reinforced fill features. Other utilities (electricity or telecom cables) should be located such that future excavation for maintenance and removal/replacement of the utilities can be carried out without damaging the reinforcing elements, or the drainage system (Figure 44(a)).

If there are no other practical alternatives, water-carrying services should be housed within a sealed trench, and drained to a suitable discharge point to prevent leakage into the reinforced fill structure or slope. The trench should be designed such that future maintenance of the services will not cause damage to the reinforcing elements, or cause disruption to the drainage system. Sub-surface drainage outlets should be so placed that they can be inspected with ease and any increase in flow can be easily identified.

## 7 Design of Reinforced Fill Structures

### 7.1 General

The design procedure provided in this chapter applies to reinforced fill structures with a vertical or near vertical facing that is within  $20^\circ$  from the vertical. Features with a facing inclined more than  $20^\circ$  from the vertical should be designed as reinforced fill slopes in accordance with the procedures and design methods given in Chapter 8.

### 7.2 Basis for Design

The design procedure for reinforced fill structures is summarised in Figure 33. The limit states which should be considered and design methods which can be used are addressed in the following sections.

The modes of failure to be considered in design should be in accordance with the principles given in Section 6.4.1. The ultimate limit states that involve failure planes entirely outside or at the boundary of the reinforced block (i.e. reinforced portion of 'compacted fill') are categorised as external instabilities, and these modes of instability should be considered in the design (Figure 28):

- Loss of overall stability.
- Sliding failure.
- Overturning failure.
- Bearing failure.

The ultimate limit states that involve failure planes located entirely within the reinforced block are categorised as internal instabilities, and these modes of instability should be considered in the design (Figure 29):

- Rupture of reinforcement.
- Pullout of reinforcement.
- Failure of connections.
- Rupture of facing panels.
- Toppling of facing blocks.
- Sliding of facing blocks.

A number of ultimate limit states that involve failure planes located within and outside the reinforced block are categorised as compound instabilities, and these modes of instability

should be covered in the design (Figure 30):

- Rupture/pullout of reinforcement.
- Sliding along reinforcement.
- Sliding on planes between reinforcement.

In addition the serviceability limit states covering excessive deformation of the reinforced fill block, settlement, translation and rotation of the structure should be guarded against in design (Figure 31).

Observation of actual failures of reinforced fill structures world-wide indicates that the external and compound instabilities are the more common modes of failure. The relatively few reported failures involving internal instabilities were normally complex and often involved a combination of the failure modes. Examples of such failures can be found in Lee et al (1994).

### **7.3 Dimensions of the Structure**

Preliminary design of the reinforced fill structure could be based on the effective height to width ratio depicted in Figure 34.

The toe of the structure should be embedded below the ground surface. The definition of embedment is depicted in Figure 34. The amount of embedment depends on various factors which include:

- (a) the pressure imposed by the structure on its foundation,
- (b) risk of piping if a water head builds up behind the wall facing,
- (c) risk of exposing the toe due to subsequent excavation (e.g. utility installation), and
- (d) risk of scouring or erosion at the toe of the structure.

The embedment depth recommended in Figure 34 is only appropriate for on-land structures where there is no risk of piping or scouring at the toe. Where it is possible that services will be placed in front of the structure in the future, the effects of trench excavation should be taken into account in the design. For example, it is prudent to design reinforced fill structures in built-up areas assuming the presence of a trench at least 1m deep at the toe.

## **7.4 External Stability**

### **7.4.1 Overall Stability**

The construction of a reinforced fill wall or abutment will result in stress changes in the ground mass containing the structure, which could result in “overall instability”, Figure 28(a).

Loss of overall stability is likely to occur in an area which is itself of limited stability (e.g. a steeply sloping site or a slope with a high groundwater level) or where a weak subsoil (e.g. a very soft clay layer) is present beneath the reinforced fill structure.

Limit equilibrium methods such as those developed by Janbu (1973) and Morgenstern & Price (1965) may be used to check overall stability. Detailed guidance on the use of such methods is given in the Geotechnical Manual for Slopes (GEO, 1984). The stability of slopes above and below the reinforced fill structure should also be considered.

#### 7.4.2 Stability of the Reinforced Block

The reinforced block should be treated as a gravity type retaining wall. The design method outlined in Geoguide 1 (GEO, 2020) for checking against sliding, overturning and bearing instability should be followed. Angle of wall friction  $\delta$  should be determined using the shear strength parameter  $\phi'_{des}$ , as defined in Section 6.6.2. [Amd GG6/01/2022]

Active earth pressures can be assumed to act at the back of the reinforced block and it is not necessary to allow for compaction-induced lateral pressures as movements that occur close to the limit states will reduce the earth pressures to the active state. Either the Rankine or Coulomb earth pressure theory can be used to determine the active earth pressure. Suggested maximum values of mobilised angle of wall friction at the back of the reinforced block for active earth pressure calculations are also given in Table 14 of Geoguide 1 (GEO, 2020). [Amd GG6/01/2022]

The presence of water behind the reinforced fill structure has a marked effect on the forces applied to the structure. Therefore, it is of utmost importance to take proper account of the appropriate water pressure in analysing the external stability of reinforced fill structures. Detailed guidance on the evaluation of design water pressure is given in Chapter 8 of Geoguide 1 (GEO, 2020). [Amd GG6/01/2022]

The imposed bearing pressure under the reinforced fill structure should be compared with the ultimate bearing capacity,  $q_{ult}$ , of the ground. A Meyerhof pressure distribution may be assumed along the base of the structure, Figure 35. Guidance on design against bearing capacity failure is provided in Appendix A of Geoguide 1 (GEO, 2020). For relatively slender reinforced block (i.e. a  $L/H_e$  ratio of say less than 0.6 for a vertical structure), the trapezoidal base pressure distribution should be assumed for the assessment of bearing capacity assessment. [Amd GG6/01/2022]

The sliding resistance of the structure at the interface between the fill and ground should be based upon the properties of either the ground or the fill material, whichever is the weaker. Consideration should also be given to sliding on or between any reinforcing layer used at the base of the wall or abutment or at any change in section.

For sliding stability where there is fill-to-ground contact at the base of the structure:

$$R_h \leq R_v \tan \phi'_{des} + c'_{des} L \dots\dots\dots(7.1)$$

For sliding stability where there is reinforcement-to-ground contact at the base of the structure:

$$R_h \leq R_v \mu_{dsD} \dots\dots\dots(7.2)$$

Where  $R_h$  = horizontal disturbing force (derived using design dead and live loads and the design shear strength parameters of the fill material)  
 $R_v$  = vertical resultant force (derived using design dead and live loads)  
 $L$  = effective base width for sliding  
 $\phi'_{des}$  = design angle of shearing resistance of the ground or fill under effective stress condition  
 $c'_{des}$  = design cohesion of the ground or fill under effective stress condition  
 $\mu_{dsD}$  = design coefficient of friction against direct sliding, Section 6.6.3

## 7.5 Internal Stability

### 7.5.1 General

Internal stability is concerned with the integrity of the reinforced block. The design for internal stability should be carried out such that there is an adequate margin of safety against the internal ultimate limit states depicted in Figure 29 during the design life of the structure.

Consideration should be given to local instability relating to rupture and pullout of the individual layers of reinforcement.

The ultimate limit states are modelled with the following assumptions:

- Design value of reinforcement parameters, geotechnical parameters and loading, as defined in Section 6.5.3, should be used directly in the design calculations.
- The design tensions in the reinforcement are determined on the basis that vertical loads are distributed throughout the reinforced block in accordance with the Meyerhof pressure distribution (Figure 35) or a trapezoidal pressure distribution in the case where the  $L/h_i$  ratio is less than about 0.6 for a vertical structure.
- Resistance of reinforcement against pullout are based on a uniform normal stress distribution developed by the unfactored weight of fill and superimposed dead load above the reinforcement layer. The influence of pore water pressures on pullout resistance should be taken into account.

### 7.5.2 Design Methods

The state of stress generated within a reinforced fill structure (see Section 3.3.6(3))

determines the design tensile load in the reinforcement. The state of stress inside the reinforced block is determined by the quantity and the axial stiffness of the reinforcement.

Where the short-term (i.e. immediately after construction) axial tensile strain of the reinforcement exceeds 1% under the design loads, the analytical method recommended is the Tieback Method (see Figure 36(a)). The method assumes:

- the lateral earth pressure within the reinforced block is in active state (i.e.  $K_{des} = K_a$ ),
- the yielding zone and the resisting zone are defined by a linear plane that inclines at an angle  $\psi$  to the horizontal and passes through the toe of the structure, which approximates the Coulomb wedge. For a vertical wall,  $\psi = 45 + \phi'_{des}/2$ , and
- the active earth pressure coefficient,  $K_a$  can be determined using the equation given in Geoguide 1 (GEO, 2020).

[Amd GG6/01/2022]

Where the short-term axial tensile strain of the reinforcement is less than or equal to 1% under the design load, the analytical method recommended is an empirical method of analysis termed the Coherent Gravity Method (see Figure 36(b)). The Coherent Gravity Method which has been described by Mitchell & Villett (1987) assumes:

- the distribution of lateral earth pressure within the reinforced block varies from at-rest state (i.e.  $K_{des} = K_o$ ) to active state (i.e.  $K_{des} = K_a$ ) in the upper 6 m of the structure and is entirely active state below the 6 m depth,
- the yielding zone and resisting zone are defined by a bilinear plane which passes through the toe of the structure, and which approximates the plane of maximum tension in the reinforcement, and
- for vertical walls, the active earth pressure coefficient,  $K_a$  can be determined using the Rankine earth pressure theory. The plane of maximum tension is defined by a vertical surface with an offset of 0.3H from the wall face in the upper half of the structure.

For walls with a face batter, an offset of 0.3H is still required for the plane of maximum tension in the upper half of the structure, but the maximum tension plane should be parallel to the wall face.

The axial tensile strain developed in steel reinforcement (strips, grids or anchors) under working conditions is generally less than 1% and this is insufficient to generate the active  $K_a$  stress-state in the upper part of the structure, hence,  $K_{des} = K_o$  can be assumed in the top 6 m of the structure.



In normal situation the short-term axial tensile strain of polymeric reinforcement will most likely exceed 1% and this is sufficient to generate the active  $K_a$  stress-state. However, if the design employs a large quantity of relatively stiff polymeric reinforcement to limit deformation, a relatively stiff structure could be developed and the Coherent Gravity Method may be the more appropriate design method.

### 7.5.3 Tension in Reinforcement

In the design of reinforced fill structures, the available tension (i.e. the tensile resistance provided by the reinforcement layers) must exceed or equal to the design tension to guard against the internal ultimate limit state caused by the rupture of the reinforcement layers.

The design tension in the reinforcing elements on any plane, should be determined using factored disturbing dead and live loads and the design shear strength parameters of the fill material. Zero pore water pressure within the reinforced block may be assumed if adequate drainage measures are incorporated in the design (see Section 7.11).

For steel reinforcement, the available tension (i.e. design tensile strength) should be calculated in accordance with Section 6.6.1(1), which takes into account the effect of corrosion. For polymeric reinforcement, the design strength of proprietary reinforcement products, where used, should be taken from the relevant reinforced fill product design data sheets.

[Amd GG6/01/2022]

The design tension,  $T_i$  to be resisted by the  $i$ th level reinforcing element or anchor at a depth of  $h_i$ , below the top of the structure, can be obtained from the summation of the following horizontal forces:

$$T_i = T_{ei} + T_{pi} + T_{fi} \dots\dots\dots(7.3)$$

(1) *Tensile force,  $T_{ei}$ .*  $T_{ei}$  due to self weight of fill plus any surcharge and overturning moment caused by earth pressures acting on the reinforced block as shown in Figure 35 is given by:

$$T_{ei} = K_{des} \sigma'_{vi} S_{vi} S_{hi} \dots\dots\dots(7.4)$$

- where  $K_{des}$  = design coefficient of lateral earth pressure  
 $\sigma'_{vi}$  = vertical effective stress acting on the  $i$ th level reinforcement  
 $S_{vi}$  = vertical spacing of the  $i$ th level reinforcement  
 $S_{hi}$  = horizontal spacing of the  $i$ th level reinforcement

$$\sigma'_{vi} = \frac{R_{vi}}{L_i - 2e_i} \dots\dots\dots(7.5)$$

- where  $R_{vi}$  = vertical resultant force acting on the  $i$ th level reinforcement  
 $L_i$  = length of the  $i$ th level reinforcement  
 $e_i$  = eccentricity of the vertical resultant force acting on the  $i$ th level

reinforcement

(2) *Tensile force,  $T_{pi}$ .* A vertical pad load  $P_L$  having an eccentricity  $e$ , applied over an area with a width,  $b_o$ , and length,  $a_o$ , on the top of the structure as shown in Figure 37 will induced a tensile force  $T_{pi}$  at the  $i$ th level reinforcement. As illustrated in Figure 37, the determination of  $T_{pi}$  is by selecting the more critical horizontal effective stress acting on the  $i$ th reinforcement due to  $P_L$ .

(3) *Tensile force,  $T_{fi}$ .* A horizontal pad load  $F_p$  applied over an area with a width,  $b_o$  and length,  $a_o$ , on top of the structure as shown in Figure 38 will induced a tensile force  $T_{fi}$  at the  $i$ th level reinforcement. As illustrated in Figure 38, the determination of  $T_{fi}$  is by selecting the more critical horizontal effective stress acting on the  $i$ th reinforcement due to  $F_p$ .

**7.5.4 Local Stability Check**

The resistance of the  $i$ th level reinforcement should be checked against rupture and pullout failure whilst carrying the design tension.

(1) *Rupture of reinforcement.* In order to guard against the rupture of reinforcement, the available tensile resistance of the  $i$ th level reinforcing element must equal to or exceed the design tension in the reinforcement:

$$T_{Di} b \geq T_i \dots\dots\dots(7.6)$$

- where  $T_i$  = design tension in the  $i$ th level reinforcement obtained from Equation (7.3)
- $T_{Di}$  = design tensile strength per unit width of the  $i$ th level reinforcement calculated in accordance with Section 6.6.1
- $b$  = width of the reinforcement

(2) *Pullout of reinforcement.* Figure 36(a) and 36(b) define the yielding zone and resisting zone in structures reinforced with relatively extensible and relatively in-extensible reinforcement respectively. When the length of the reinforcement within the resisting zone are unable to mobilise sufficient shear resistance, the reinforcing elements tend to pull out, producing gross distortions in the structure, or even triggering a collapse.

The available design pullout resistance of individual reinforcing elements or anchors must be equal to or exceed the design tension in the reinforcement to guard against the pullout failure mechanism. The pullout resistance of reinforcing element is computed using unfactored weight of the fill and superimposed dead load acting on the length of the reinforcement embedded in the resisting zone, and the design coefficient of friction against pullout, Section 6.6.3. For steel reinforcement, the effect of corrosion should also be taken into account in deriving the design pullout resistance.

For proprietary polymeric reinforcement, the pullout resistance could be determined from the relevant reinforced fill product design data sheets. For generic forms of reinforcement (e.g. steel grids or anchors), the pullout resistance could be determined using the equations given in Section 3.4.2.

- (a) Pullout of strip, sheet or grid reinforcement. The criterion for satisfying local stability considerations against pullout of reinforcement is:

$$T_{pDi} \geq T_i \dots\dots\dots(7.7)$$

where  $T_{pDi}$  = design pullout resistance of the  $i$ th level reinforcement  
 $T_i$  = total design tension to be resisted by the  $i$ th level reinforcement, Equation (7.3)

and

$$T_{pDi} = 2\mu_{pD}(\gamma'h_i + q_s)b_iL_{ei} \dots\dots\dots(7.8)$$

where  $\mu_{pD}$  = design coefficient of friction against pullout, Section 6.6.3  
 $\gamma$  = effective unit weight of the fill material  
 $h_i$  = height of reinforced block above the  $i$ th level reinforcing element  
 $q_s$  = surcharge due to unfactored superimposed dead loads only  
 $b_i$  = horizontal width of the reinforcing elements  
 $L_{ei}$  = length of the  $i$ th level reinforcing element beyond the yielding zone, Figure 36

- (b) Pullout of anchor reinforcement. The design pullout resistance of an anchor reinforcement at the  $i$ th level may be determined from:

$$T_{pDi} = \frac{P_{all}}{\gamma_n} \dots\dots\dots(7.9)$$

where  $P_{all}$  = allowable pullout resistance of anchor at the  $i$ th level  
 $\gamma_n$  = partial factor to account for consequence of internal failure, Table 3

Where the distance between the potential failure plane and the start of the anchorage is less than 1 m, the pullout resistance of that anchor layer should be neglected.

**7.5.5 Wedge Stability Check**

After checking rupture and pullout of individual layers of reinforcement, limit equilibrium analysis should be undertaken to check the potential wedge failures within the reinforced block. A selection of potential wedge failures should be investigated for each of the typical points, a, b, c, etc., shown in Figure 39. For each of the typical points the maximum value of the total tensile force, T to be resisted by the reinforcement should be established by analysing the forces acting on a number of different wedges.

For the case of a wall with a level top containing granular fill and which supports uniform surcharge only, the inclination of potential failure plane to the horizontal may be taken as  $\phi = 45^\circ + \phi'_{des}/2$ . However, in the more complex case it is not possible to give guidance on

either the angle of the potential failure plane that produces the maximum value of 'T' or the number of points which should be checked. The designer should take into account all the potential wedges based on the geometry and loading conditions of the reinforced fill structures.

Stability of any wedge inside the reinforced block is maintained when shear resistance acting on the potential failure planes in conjunction with the tensile/pullout resistance of the group of reinforcing elements embedded in the fill beyond the plane is able to resist the destabilising loads. Wedges are assumed to behave as rigid bodies and may be of any size and shape.

The resistance provided by an individual layer of reinforcement should be taken as the lesser of either:

- the pullout resistance of that layer of reinforcement embedded in the fill beyond the potential failure plane, or
- the design tensile resistance of that layer of reinforcement.

The total resistance of the layers of reinforcement anchoring the wedge to achieve overall stability is:

$$\sum_{i=1}^n \text{Min}[T_{pDi}, T_{Di}b] \geq T \dots\dots\dots(7.10)$$

where      T = total tensile force to maintain wedge stability  
 $T_{pDi}$  = design pullout resistance of the *i*th level reinforcement  
 $T_{Di}$  = design tensile strength per unit width of the *i*th level reinforcement  
 n = number of layers of reinforcement  
 b = width of reinforcement

## 7.6 Compound Stability

### 7.6.1 General

The development of failure planes, either planar or circular, located within and outside the reinforced block represents the ultimate limit states of compound instabilities, Figure 30. Wedges of any size and shape are assumed to behave as rigid bodies and their stability are maintained when the shear resistance acting on the potential failure planes in conjunction with the tensile/pullout resistance of the group of reinforcing elements embedded in the fill beyond the failure plane are able to resist the destabilising loads, Figure 40. Wedge stability should be checked using the design dead and live loads and the design shear strength of the fill material.

### 7.6.2 Rupture/Pullout of Reinforcement

Particular cases where the compound failure planes could lead to rupture and/or pullout of the reinforcement should be investigated (Figure 30(a)). Compound failure planes could be

depicted in the form of two-part wedges. As shown in Figure 40, a closed force polygon acting on Wedge 1 allows the determination of the tensile/pullout resistance to stabilize the potential wedge failure mechanism. By ignoring the inter-wedge shear forces, two-part wedge failure mechanisms normally produce a conservative solution. If inter-wedge shear forces between Wedges 1 and 2 are used in the analysis the resultant vertical force acting on the back of Wedge 1 can produce both stabilising and destabilising effects depending upon the gradient of the potential failure plane. In the case of sliding on low angle wedge planes, the inter-wedge shear force will be a stabilising force, but for steeper wedges it will be a destabilising force.

In the design of a bridge abutment wall, it may be assumed that no potential failure plane will pass through the contact area representing a bridge bank seat (Figure 41). For wall facing consists of a structural element formed in one piece (i.e. full height facing) the shear resistance provided by the facing could be considered when designing against failure planes passing through the facing.

### **7.6.3 Sliding on Planes between Reinforcement**

The compound failure mode in which the potential failure planes are located between two adjacent layers of reinforcement should be considered (Figure 30(b)). The resistance to sliding of the reinforced block is provided by the shear resistance of the fill material along the potential failure plane.

The stability of the structure in relation to sliding of the reinforced block along planes between reinforcement layers should be considered at every steepest plane between any two layers of reinforcing elements (Figure 42(a)).

### **7.6.4 Sliding along Reinforcement**

Particular cases where compound failure planes coincide with the reinforcement layers should be considered (Figure 30(c)). In this compound failure mode, the resistance to direct sliding of the reinforced block is provided by the fill-reinforcement interaction along the potential failure plane.

The stability of the structure in relation to sliding of the reinforced block along the reinforcement layers should be considered at every layer of reinforcement (Figure 42(b)).

## **7.7 Serviceability Considerations**

### **7.7.1 Serviceability Check**

The serviceability limits, including the permissible displacements and angular distortions of the facilities to be supported by the reinforced fill structure should be established at an early stage of the design (see Section 6.7.1).

The bulk of the movements of reinforced fill structures take place during construction. Such movements are dependent on the method and sequence of construction. Additional

movements subsequent to the completion of construction may be caused by:

- creep of polymeric reinforcement,
- creep of fine grained soil fill,
- additional surcharge loading not considered in design,
- foundation settlement, and
- deterioration of the reinforcement due to metal corrosion or polymer degradation.

Experience shows that post construction horizontal movements due to creep strain of polymeric reinforcement is limited mainly due to the accompanying strain hardening of the fill material (see Section 3.3.3(6)). Fill conforming to the requirements of the model specification of this guide is unlikely to creep.

Reinforced fill structures can normally tolerate settlement and differential settlement greater than those acceptable with conventional retaining structures. Nevertheless, serviceability limit states should be specifically considered and appropriate checks (e.g. on tilting and settlement of the wall) should be carried out where the consequence of a serviceability limit state being reached is severe, or where movements could lead to distress in the wall. For example, walls which are designed to support bridge abutments and walls which are subject to heavy surcharge deserve special consideration. The effects of consolidation settlement due to any compressible layer in the foundation also warrant attention. Consideration should be given to providing the necessary clearances to permit the structure to attain a stable configuration and also to ensure that construction and post-construction movements are within acceptable limits. Guidance on the serviceability limits of reinforced fill structures are provided in Section 6.7.3.

### **7.7.2 Differential Settlement**

The possibility of differential settlement along the length of the reinforced fill structure should be considered when the foundation material is likely to be variable or when compressible spots exist.

It is often the facing of the structure that determines the limits to differential settlement. Where large differential settlements are anticipated, special slip joints should be incorporated into the facing and detailed on the construction drawings.

Reinforced fill bridge abutments are able to accommodate differential settlements significantly in excess of the established tolerable movements criteria for bridge decks, (Moulton et al, 1982). In these conditions special structural precautions should be used with regard to the bridge superstructure (Worrall, 1989; Sims and Bridle, 1966; Jones and Spencer, 1978).

## 7.8 Spacing of Reinforcement

The arrangement and layout of reinforcing elements should be chosen to provide stability and to suit the size, shape and details of the facing units. The theoretical spacing of the reinforcement is likely to require different reinforcement densities at every level in the structure. This may be impractical and the use of a constant reinforcement section and spacing configuration for the full height of the wall or abutment may provide more reinforcement at the top of the structure than is required. A more economic design may be possible with the reinforcement intensity varied with depth. This can be achieved by:

- For metallic reinforcement consisting of strips, grids and anchors, the vertical spacing ( $S_v$ ) is maintained constant and the reinforcement density is increased with depth by reducing the horizontal spacing ( $S_h$ ) or changing the reinforcement size, strength or grade.
- For polymeric grid or geo-synthetic sheet reinforcement the reinforcing density can be increased by reducing the vertical spacing ( $S_v$ ) with depth. Alternatively the reinforcement density can be varied by changing the design strength of the reinforcement. This is particularly useful with a wrap-around form of construction where a constant wrap height is desirable. For tall structures reinforced with polymeric grids or geo-synthetic sheets, double layers of reinforcement can be provided.
- For segmental block walls the low height of the blocks can make it impractical/uneconomic to place reinforcement at each level. The maximum spacing should not exceed the maximum stable unreinforced height and the normal rule of thumb is the spacing of reinforcement should not exceed two times the block depth (i.e. front face to back face).
- For the common elemental facing systems comprising 1.5 m high units, at least two rows of reinforcement should be attached to each facing element.

## 7.9 Design of Connections

### 7.9.1 Failure of Connections

Failure of the connections between individual reinforcing elements and the connections on the facing elements should be checked using the design tensile force,  $T_i$  developed in the individual layers of reinforcement, Section 7.5.3. In addition any shear and bending stresses resulting from settlement of the fill relative to the facing should be considered in the design of the connections.

For bolted connections, all modes of failure, including shear and bearing failures, should

be checked. For reinforced concrete facing units, the design should check against the possibility of local failure of concrete resulting in the connections being pulled out of the facing units. All the connections on a facing unit should be taken to be loaded simultaneously in order to check the effect of any overlapping stressed zones in the concrete.

In the case of segmental block walls, the strength of the connections between the reinforcement and the facing units may be less than the long term design strength of the reinforcement, in which case the connection strength instead of the reinforcement strength should be used in the stability assessment of the segmental block facing (see Section 7.13.2(3)).

### 7.9.2 Metallic Connections

When calculating the load carrying capacity of galvanised steel connections allowance should be made for corrosion as follows:

- A sacrificial thickness in accordance with Table 2 should be deducted from the surface of all component parts of the connection in contact with the soil.
- Metallic sections that are coupled together and not in contact with the soil can still corrode, a sacrificial thickness of 0.5 times the value given in Table 2 should be deducted from each internal surface of all component parts in close metal-to-metal contact or wholly enclosed within the connection (BS 8006-1 (BSI, 2010)). [Amd GG6/01/2017]

### 7.9.3 Polymeric Connections

Polymeric connections should be designed against failure in tension, shear and combined tension and shear and also in accordance with the performance characteristics of the different jointing methods shown in Figure 26. Where galvanised steel components are used for the connection, the sacrificial thickness to be allowed for should be in accordance with Table 2. The forms and materials used for connection systems between the facing and the reinforcement are considered in Section 4.2.4.

## 7.10 Design of Facing Elements

### 7.10.1 Hard Facings

Facing elements should be designed to resist lateral earth pressures generated in the reinforced fill. Analysis of the structural requirements can be undertaken by assuming the facing is a continuous beam supported at the reinforcement/facing connections and loaded by lateral earth pressures developed in accordance with Section 7.5.2.

Some full height facing systems formed from reinforced or pre-stressed concrete are subjected to greatest bending stresses during erection. This loading case should be considered



in the design of the facing and where appropriate notes should be made on the construction drawings with regard to erection procedures.

### **7.10.2 Flexible Facings**

Facing systems formed from welded wire, expanded metal or from polymeric materials should be designed to accommodate the vertical distortion and bulging which can occur during construction with these materials. Excessive bulging may be prevented with the provision of lighter secondary reinforcement between the main reinforcement (see Figure 43(b)).

## **7.11 Drainage Provisions**

### **7.11.1 Design Aspects**

The stability of reinforced fill structures is dependent upon proper drainage provisions. An increase in pore water pressure within the reinforced block can reduce the overburden pressure on the reinforcement thus reducing pullout and sliding capacities.

Water can enter a reinforced fill structure in several ways:

- (a) Water can percolate from the top of the reinforced block unless effective sealing details are provided.
- (b) Groundwater can flow into the structure from the retained ground. This is usually significant in cases of structures supporting roads or building platforms along hillsides where water can emerge from the natural ground behind the structure.
- (c) Water can enter the structure through defective water service, sewerage and storm water drainage pipes.

The surface and sub-surface drainage system to be provided should be designed for the anticipated water flow without backing up or blocking. To prevent the blockage of sub-surface drainage, the drain or drainage material should be protected by suitable filter material. In some cases, the filter material may have an adequate permeability to provide the necessary drainage capacity. Guidance on the design of sub-surface drainage for earth retaining structures is provided in Geoguide 1 (GEO, 2020). [Amd GG6/01/2022]

The thickness of granular drainage/filter layers is often governed by construction considerations rather than by the drainage capacity criterion. In line with Geoguide 1, a partial material factor of 10 should be applied to the permeability of granular filter and drainage materials in drainage design (Table 6).

It is important that the drainage system is provided with sufficient discharge points. These should be connected to suitable outlets. Weep-holes should not be relied upon as the sole means of discharge. Drainage pipes should be provided for removing sub-surface water.

### 7.11.2 Design Detailing

(1) *Surface drainage.* Structures located along the downhill side of highways should be provided with robust surface drainage details. Channels with removable, perforated covers may be provided along the crest of downhill retaining structures as they are easy to maintain and do not become blocked easily as buried drainage pipe systems with gullies at wide spacings. If deep drains are required to be constructed along the crest of reinforced fill structures, it is common practice to construct a self standing upstand on top of the reinforced fill wall to avoid clashing with the top layer of reinforcement.

For part height walls, a drainage channel should be provided immediately behind the wall crest along the slope toe to remove water running off the side slope (Figure 43(a)). Guidance on the design of surface drainage for highway structures and slopes is provided in the Highway Slope Manual (GEO, 2000).

(2) *Sub-surface drainage.* For locations where water flow is expected from the retained ground, a filter/drainage layer should be provided beneath the reinforced block and continue up along the face of the temporary excavation for as high as is needed. It is recommended that the sub-surface drainage pipe within the filter/drainage layer be located in front of the facing. Sub-surface drainage pipe located behind the facing is not recommended because of the following reasons:

- (a) differential settlement along the length of the wall could affect the falls of the drainage pipe, and
- (b) access for maintenance is restricted.

Where necessary, a continuous filter layer should be incorporated at the top of the reinforced block to prevent the migration of fines from the backfill into the block (Figure 43(a)).

Where an elemental facing system is adopted for river training works, provision should be made for a continuous vertical filter layer to be placed immediately behind the facing, connected to the drainage system at the base of the structure (Figure 44(b)). This filter layer is to prevent the loss of fines through the gaps of the elemental facing system due to fluctuation of water levels.

The typical sub-surface drainage layouts shown in Figures 43 and 44 may be varied to suit the conditions met during construction without changing the reinforced fill details.

The adequacy of the subsurface drainage capacity of a reinforced fill structure should be assessed and regularly reviewed during construction, taking account of the changing site topography and temporary drainage provisions. The design and detailing of the subsurface drainage system of the reinforced fill structure should be robust enough against the build-up of water pressure from unintended ingress of water, which may cause hydraulic (piping) failure, internal or external instability, or distress.

[Amd GG6/01/2017]

### 7.11.3 Temporary Drainage

Due attention should also be given to ensuring adequate temporary drainage provisions and precautionary and mitigation measures to discharge the surface water and subsurface water safely during construction. Details are further elaborated in Section 11.2.5. [Amd GG6/01/2017]

### 7.12 Superimposed Walls

In some situation, it is more appropriate to use stepped walls in place of a single retaining structure. For a tall retaining structure, a stepped wall section generally has a better tolerance against cumulative lateral deformations than a straight wall section. A stepped wall section also provides more flexibility for the application of landscaping works to reduce the visual prominence of tall retaining structures.

The design of superimposed walls depends upon the geometrical positioning of the walls forming the overall structure. The criteria for a retaining structure to be designed as superimposed walls are presented in Figure 45. The governing geometrical dimension is the offset distance  $D$  between the individual wall sections:

- For a small offset where  $D \leq (H_1+H_2)/20$ , it is assumed that the plane of maximum tension does not fundamentally change, hence the individual walls should be designed as a single structure.
- For structure with a large offset where  $D > H_2 \tan(45^\circ - \phi'_{des}/2)$ , the individual walls are acting independently without interfering each other, hence they should be designed as independent structures.
- For intermediate offset distance where  $(H_1+H_2)/20 < D \leq H_2 \tan(45^\circ - \phi'_{des}/2)$ , the individual walls should be designed as superimposed walls.

Stability analyses on external, internal and compound failures are carried out in accordance with Sections 7.4, 7.5 and 7.6. For external stability, the upper and lower walls should be analyzed as independent, conventional gravity walls and the upper wall may be considered as surcharge on the lower wall. For internal stability, the planes of maximum tension for in-extensible and extensible reinforcement of different offset distance  $D$  is defined in Figure 45. Additional vertical pressure calculated in accordance with Figure 46 for different offset distance  $D$  should also be included in internal stress calculations.

### 7.13 Segmental Block Walls

#### 7.13.1 General

The design of segmental block walls generally follows the principles and methods

illustrated in Sections 7.4 to 7.9. However, the discrete nature of the dry-stacked construction method of reinforced segmental block wall introduces additional local stability considerations.

(1) *Facing stability.* Stability checks are required to ensure the column of block units remains intact. The vertical spacing of reinforcement layers must be restricted and the interface shear capacity between block units and the block-to-reinforcement interaction must be adequate to prevent shear failure between successive courses of facing units. In addition, the unreinforced height of block units at the top of the structure must not lead to toppling or sliding of the units near the crest of the wall. The toppling and block sliding modes of failure are illustrated in Figure 29(e) and 29(f).

Shear transfer between block layers is developed primarily through shear keys and interface friction. However, for interface layers under low normal stress (e.g. close to the top of the structure), a significant portion of shear transfer may be developed by mechanical connectors or the provision of reinforcement layers to prevent toppling and sliding failures of the wall crest.

(2) *Earth pressure acting on facing.* Reinforced segmental block walls are commonly constructed with a wall batter ( $\alpha$ ) by setting back the block units as illustrated in Figure 47. In order to account for the wall batter ( $\alpha$ ), backslope angle ( $\beta$ ) and shear mobilised at the interfaces between the block units and the reinforced fill (interface friction angle  $\delta$ ), the Coulomb earth pressure theory can be used to determine the active earth pressure coefficient,  $K_a$  of the reinforced fill. The Coulomb equation for determining the  $K_a$  value of the reinforced fill behind the facing is presented in Figure 47.

The state of stress and the distribution of earth pressure behind the facing are determined by the stiffness of the reinforcement used. The distribution and magnitude of earth pressure acting on the segmental block facing should be in accordance with the requirements given in Section 7.5.2. For walls reinforced with relatively extensible reinforcement, the analytical model recommended is the Tieback Method. For walls reinforced with relatively in-extensible reinforcement, the analytical model recommended is the Coherent Gravity Hypothesis.

### 7.13.2 Design of Facing

Calculation of shear capacity at the unit-to-unit and the unit-to-reinforcement interface requires an estimate of the normal stress transmitted between the units to be made. As the normal stress between the units is developed by the weight of the units, it will vary from a minimum in the upper portion of the structure to a maximum near the bottom of the structure for walls with no batter. Since many reinforced segmental block walls are constructed with a front batter, the column weight above the base of the wall or above any other interface may not correspond to the weight of the facing units above the reference elevation. Hence, for walls with a front batter, the magnitude of normal stress will depend on the following:

- height of the facing column above any interface,
- inclination of the facing column, and

- mobilised shear resistance at the interface between facing column and fill.

(1) *Hinge height.* An estimate of the normal stress between facing units can be made by calculating the hinge height ( $H_h$ ) of the column of units.  $H_h$  is defined as the maximum height of an isolated column of units that can be stacked at a facing inclination of  $\alpha$  without toppling. The purpose of the hinge height concept is to restrict the maximum design weight of the dry-stacked column of units that can be transferred to the wall base or underlying courses. As illustrated in Figure 48, toppling of the isolated column will occur when the weight of the column outside the heel of the lowermost unit exceeds the weight of the column inside the heel (i.e.  $M_B > M_A$ ).  $H_h$  is measured vertically and can be expressed by the following equation:

$$H_h = \frac{2(W_u - G_u)}{\tan \alpha} \dots\dots\dots(7.11)$$

where  $W_u$  = width of the unit  
 $G_u$  = distance to the centre of gravity of the unit measured from the front face  
 $\alpha$  = wall batter

For wall with a batter,  $H_h$  should be used as a maximum height in the calculation of normal stress acting on any unit-to-unit interface. In the case of a true vertical facing ( $\alpha = 0$ ):

$$H_h = H_i \dots\dots\dots(7.12)$$

where  $H_i$  = total height of wall above the interface

(2) *Stability of facing near the wall crest.* The facing units above the highest reinforcement layer must be examined to ensure that they will perform as a free standing retaining wall. The examination of the upper unreinforced column of units for sliding and toppling failure modes is done in the same manner as for a conventional gravity wall, with the destabilising force resisted solely by the weight of the facing units.

In order to limit tilting, the stacked units should be proportioned in such a way to ensure that the resultant force acts within the middle third of the base of the unit under the worst loading combination. In applying the middle third rule, the overturning and resisting movements calculated should be based upon unfactored dead and live load and unfactored shear strength parameters of the fill material.

(3) *Block sliding failure.* Resistance against block sliding failure is controlled by the weight of the facing column, vertical spacing of the reinforcement layers and the shear capacity between the facing units. In order to maintain internal stability all facing units must possess sufficient shear capacity to resist the horizontal earth pressure being applied between layers of reinforcement.

For analysis of block sliding failure, the dry-stacked facing units can be modelled as a continuously supported beam in which the lateral earth pressure is taken as the distributed load and the reinforcing elements as supports. Using a simplified equivalent beam method, a shear force diagram can be generated. The shear force diagram shown in Figure 49 illustrates that the

maximum shear forces occur at the reinforcement elevations.

The shear force diagram can be constructed by summing the out-of-balance horizontal forces above each interface elevation starting from the top of the wall and proceeding to the bottom of the wall. The maximum shear (out-of balance) force at any interface is the difference between the distributed load (i.e. earth pressure) and the available reinforcement tension above that interface.

When considering the block sliding failure at the interface between units, the available design shear capacity at any unit-to-unit or unit-to-reinforcement interface level can be calculated using the following equation:

$$V_{iD} = a_{des} + N_i \tan \lambda_{des} \dots\dots\dots(7.13)$$

- where  $V_{iD}$  = design shear capacity per unit length at the *i*th level interface
- $N_i$  = normal load per unit length acting at the *i*th level interface
- $a_{des}$  = design adhesion at the unit-to-unit or unit-to-reinforcement interface
- $\lambda_{des}$  = design friction angle at the unit-to-unit or unit-to-reinforcement interface

The coefficients  $a_{des}$  and  $\lambda_{des}$  should be determined in accordance with Section 6.6.4. Normal load  $N_i$  per unit length acting at the *i*th level interface is given by:

$$N_i = H_h \gamma_u W_u \dots\dots\dots(7.14)$$

- where  $H_h$  = hinge height, Section 7.13.2(1)
- $\gamma_u$  = unit weight of facing units
- $W_u$  = width of facing units

In order to guard against block sliding failure, the design shear capacity at an interface level must equal to or exceed the maximum required shear force at that interface:

$$V_{iD} \geq V_i \dots\dots\dots(7.15)$$

- where  $V_{iD}$  = design shear capacity at the *i*th level interface
- $V_i$  = maximum required shear force at the *i*th level interface

**7.14 Walls with a Stepped Base**

In situations where temporary excavation is required for the construction of a reinforced fill structure, a stepped wall section is more efficient because the size of the overall excavation and filling would be reduced particularly for wall construction on sloping terrain. However, the use of this type of wall geometry should be considered only if the base of the reinforced block is founded on a very competent foundation such as rock.

Care has to be taken when constructing a reinforced fill structure with a stepped base because "soil arching" between the stepped footing and part of the reinforced fill could result in reduced vertical pressure being developed on the rear portion of the reinforcing elements. This

can be caused by internal compression of the reinforced fill adjacent to foundation steps (Figure 50(a)). Development of arching in the fill can be reduced by judicious sizing of the structure, particularly by limitation of the size of the horizontal steps (Figure 50(b)). Particular care needs to be given to the development of full compaction adjacent to each step, and a note regarding the importance of compaction should be provided on the construction drawings.

Design for external stability of walls with a stepped base should be considered in accordance with Section 7.4.

For internal and compound stability calculations, the wall is divided into rectangular sections identified by the different lengths of the reinforcement and each section analysed separately in accordance with the requirements of Sections 7.5 and 7.6.

### 7.15 Back-to-Back Walls

Back-to-back walls are two separate walls with parallel facings (Figure 51). This type of wall configuration can lead to modified values of the backfill thrust that influence the stability of the structure. As indicated in Figure 51, two cases can be considered.

In Case I, there is no overlapping of the reinforcement. When the distance,  $D$ , between the back of each wall of a height,  $H$ , is larger than  $H \tan (45^\circ - \phi'_{des}/2)$  the active wedge behind each reinforced block can fully spread out and each wall should be treated as an independent structure. When  $D$  is less than  $H \tan (45^\circ - \phi'_{des}/2)$  the full active backfill thrust cannot be developed. However, to simplify the calculation the reduction of the active thrust could be ignored and the external, internal and compound stability of each structure should be assessed independently in accordance with Sections 7.4, 7.5 and 7.6 respectively.

In Case II, there is an overlapping of the reinforcement so that the two walls are acting as an integral unit. For external stability, only the overall instability and bearing failure modes are relevant. For internal stability the walls should be assessed separately in accordance with Section 7.5, but assuming zero lateral earth thrust from the backfill.

When designing back-to-back walls, some designers might be tempted to use single reinforcement connected to both wall facings. This structural arrangement results in a 'tied' structure with higher reinforcement tensions. This form of structure is not strictly reinforced fill and is not considered in this Guide. In addition, difficulties in maintaining wall alignment could be encountered during construction, especially when the opposite wall facings are not parallel to each other.

### 7.16 Bridge Abutments

#### 7.16.1 General

Reinforced fill bridge abutments can be classified into two categories:

- (i) An abutment supporting a bank seat located directly on top of the reinforced fill block (Figure 41(a) and 41(b)).

- (ii) An abutment bank seat supported on piles which pass through the reinforced fill block (Figure 41(c) and 41(d)).

Stability assessment of bridge abutments follows the procedures used for reinforced fill walls, detailed in Sections 7.4 to 7.6.

### 7.16.2 Abutments on Spread Footings

An abutment supporting a bank seat located directly on reinforced fill is applicable when the majority of the settlement occurs during construction of the reinforced fill structure and the remaining settlement due to the construction of the bridge deck is minimal.

Vertical loads developed by the bridge are considered as superimposed loads acting on the bank seat and the dispersal of the strip loading is in accordance with Figure 37.

Horizontal loads developed through thermal movements of the bridge deck and vehicles braking are considered as horizontal shear forces acting on the bank seat and the distribution of the shear forces is in accordance with Figure 38. With conventional bank seats, horizontal forces can be resisted by the use of reinforcement connected to the bank seats.

It is common practice to locate the bank seat within the yield zone of the reinforced fill block. However, if a large surcharge slab is required at the top of the reinforced fill structure, the shape of the potential failure surface has to be modified to extend to the back edge of the bank seat, as indicated in Figure 41(b).

### 7.16.3 Abutments on Piled Foundations

When the bank seat is supported on piles the wall is designed with no consideration to the vertical bridge loads, which are transmitted to the appropriate bearing strata by the piles. However, the horizontal bridge loads acting at the bank seat must be resisted by methods dependent on the type of abutment support.

(1) *Conventional abutments.* The horizontal forces may be resisted by extending reinforcement from the back edge of the abutment footing. Alternatively the horizontal forces may be resisted by the pile lateral bending capacity.

(2) *Integral abutments.* The horizontal force and its distribution with depth may be determined using pile load/deflection methods. This force is added as a supplementary horizontal force to be resisted by the wall reinforcement. This force will vary depending on the horizontal load, pile diameter, pile spacing and distance from the pile to the back of wall panels.

Experience relating to the design of integral bridge abutments (see Figure 41(d)) indicates that:

- (a) The front edge of the bank seat piles should be located at least 0.5 m from the back face of the facing panels.



- (b) The pile casings and the reinforced fill abutment are best constructed to the full height prior to pile installation.
- (c) Cutting or curtailing reinforcement to accommodate the pile casings should not be permitted.

## **7.17 Design Detailing**

### **7.17.1 Corner and Wall Joint Details**

The wall corners of a reinforced fill structure should be provided with vertical joints to accommodate differential settlement. Suitable sealing measures should be provided along the corner joint to prevent the loss of fines through the joint gaps.

Differential settlement along a reinforced fill structure can be accommodate by the provision of vertical slip joints along the length the structure. In detailing a vertical slip joint, suitable sealing measures should be provided along the joint to prevent the loss of fines through the joint gaps.

Typical corner and wall joint details are shown in Figures 52 and 53.

### **7.17.2 Termination to Cast-in-place Structures**

The interface between a reinforced fill structure and a cast-in-place structure should be protected from the loss of fines and should allow for differential settlement between the two types of construction. Figure 53 shows details which have been found to be suitable. The detail shown in Figure 53(b) may be better suited to flexible reinforcement than the detail shown in Figure 53(c).

## 8 Design of Reinforced Fill Slopes

### 8.1 General

The design procedure provided in this chapter applies to reinforced fill features with a face inclination of more than  $20^\circ$  from the vertical. Features with a facing inclined within  $20^\circ$  from the vertical should be designed as reinforced fill structures in accordance with the procedure and design methods given in Chapter 7.

### 8.2 Basis for Design

The design procedure for reinforced fill slopes is shown as a flow-chart in Figure 54. The limit states which should be considered and design methods which can be used are addressed in the following sections. The modes of instability to be considered in design should be in accordance with the principles given in section 6.4.2.

The ultimate limit states that involve the following modes of external instability should be considered in the design, Figure 28:

- Loss of overall stability.
- Sliding failure.
- Bearing failure.

It is possible that the ultimate limit state assessment of external stability may highlight a problem of unserviceability rather than collapse, e.g. an inadequate factor of safety against bearing failure may result in large deformation not collapse.

The ultimate limit states that involve the following modes of internal instability should be considered in the design, Figures 29 and 55:

- Rupture of reinforcement.
- Pullout of reinforcement from the resisting fill mass.
- Pullout of reinforcement from the yielding fill mass.
- Rupture of structural facing elements and connection.

The ultimate limit states that involve the following modes of compound instability should be considered in the design, Figure 30:

- Rupture/pullout of reinforcement.
- Sliding on reinforcement.

- Sliding on planes between reinforcement.

In addition the serviceability limit states covering excessive settlement, translation, rotation and distortion of the reinforced fill mass should be guarded against in design, Figure 31.

### 8.3 External Stability

The assessment of external stability for reinforced fill slopes is based on the procedures adopted for reinforced fill structures given in Section 7.4.

In checking the overall stability of the slope, it is necessary to evaluate potential deep-seated failures in the ground mass containing the reinforced block and to provide adequate margin of safety against this mode of failure, Figure 56(a).

For steep reinforced fill slopes (say, with slope angle ranged from  $60^\circ$  to  $70^\circ$ ) sliding can occur along the base of the reinforced block and a two-part wedge failure mechanism may be assumed for simplicity, Figure 56(b). For less steep slopes (say, with slope angle less than  $60^\circ$ ) the two-part wedge failure mechanism could underestimate the required dimension of the reinforced block and it is more reliable to determine the critical failure surface using the limit equilibrium analysis recommended in Section 7.4.1.

The stability of the reinforced block should be checked to ensure that it does not translate or unduly subside as a monolith, Figure 28. The methods recommended in Section 7.4.2 for checking against sliding and bearing instability should be followed.

Local bearing failure could occur at the toe of reinforced fill embankments founded on soft soil strata. Determination of the destabilising and stabilising forces against lateral squeezing can be determined by considering the weight of the embankment and the undrained shear strength of the soft soil strata, Silvestri (1983). When the thickness of the soft soil is larger than the width of the slope, the likelihood for local bearing failure at the slope toe will diminish and a general bearing failure may govern the design.

### 8.4 Internal Stability

#### 8.4.1 Modes of Internal Failure

Internal stability is concerned with the integrity of the reinforced block. A reinforced fill slope has the potential to fail due to rupture or pullout of the reinforcement or failure at the connection or facing. In checking internal stability, consideration should be given to the following:

- local stability of individual reinforcing elements, and
- stability of the yielding reinforced fill mass.

The design for internal stability should be carried out such that there is an adequate

margin of safety against the internal ultimate limit states depicted in Figures 29 and 55 during the service life of the slope. The arrangement and layout of the reinforcement should be chosen to provide stability and to suit construction.

The ultimate limit states are modelled with the following assumptions:

- Design values of reinforcement parameters, geotechnical parameters and loading, as defined in Sections 6.5 and 6.6, should be used directly in the design calculations.
- Resistance of reinforcement against pullout are based on a uniform normal stress distribution developed by the unfactored weight of the fill and superimposed dead load above the reinforcement layer or anchor. The influence of pore water pressures on pullout resistance should be taken into account.
- In the assessment of the design tension in the individual reinforcement layers to maintain slope stability, increase in stress due to compaction should be considered. A simplified method of assessment of compaction-induced stress within the reinforced fill zone is depicted in Figure 57.
- For instability limit states of pullout failure, the deformation would be sufficiently large for relaxation of the compaction-induced stress. It may therefore be considered in the design that the compaction-induced stress is zero.

#### **8.4.2 Tension in Reinforcement**

The total horizontal force to maintain a slope in equilibrium may be calculated by rigorous methods of limit equilibrium analysis. In applying the limit equilibrium method of analysis, a sufficient number of potential failure surfaces should be tried to obtain the 'worst' case (i.e. maximum design tension) for design. Curved or multi-part wedge failure surfaces may be adopted. The analysis should be applied at different depths, particularly where the upslope ground profile is complex or where localised surcharges are present, to obtain the pressure distribution with depth and hence the design tensile forces at different depths.

The total horizontal force to maintain the stability of a slope depends on the lines of action of the forces. Hence, the lines of action of the forces assumed in analysis should correspond to the position of the reinforcing elements in a reinforced fill slope. In general, the lower the level of the line of action of the resultant of the forces, the smaller would be the total force required to hold the slope in equilibrium. As reinforced fill slopes are normally more heavily reinforced at the lower portion, a safe estimate of the design tension can be obtained via some simplified assumptions made on the distribution of the horizontal forces in the analysis. As illustrated in Figure 58 the design tension  $T_i$  to be resisted by the  $i$ th level reinforcing element can be calculated from the design pressure distribution diagram derived from the

maximum design tensile forces to maintain the equilibrium of the potential failure masses at different depths.

For a simple upslope ground profile or where only simple uniform surcharge is present, a two part wedge method of analysis (Schertmann et al, 1987; Jewell, 1990) as depicted in Figure 59 can be used to give a quick, preliminary estimate of the design tension in the reinforcement. However, for less steep (say, slope angle less than 60°) slopes, the two-part wedge failure mechanism may not be able to model precisely the potential failure surfaces, and it may underestimate the design tension of the reinforcement.

### 8.4.3 Local Stability Check

The resistance of the individual layers of reinforcement should be checked against rupture and pullout failure whilst carrying the design tension.

(1) *Rupture of reinforcement.* The rupture of the individual layers of reinforcement at different levels within the reinforced block should be checked in accordance with the guidelines given in Section 7.5.4(1).

(2) *Pullout of reinforcement.* When checking against pullout failure, the effective bond length of the reinforcing element should be taken as that which protrudes beyond the potential failure surface under consideration. As such, the yielding zone is defined as the portion of the slope in front of the potential failure surface. It should be noted that the potential failure surface that requires the maximum horizontal force to maintain equilibrium may not necessarily be the critical failure surface in checking against pullout failure. Hence, a sufficient number of potential failure surfaces should be checked to ensure that the pullout resistance is adequate in all cases.

Where no structural facing is provided at the slope face, pullout of reinforcement due to inadequate bond length of a reinforcing element within the yielding fill mass, as illustrated in Figure 55, should be checked, particularly in case of a shallow failure surface where the overburden pressure,  $\sigma_{vf}$  is reduced. With this failure mode, the reinforcement load carrying capacity can be limited by the bond length available near the surface of the slope.

The pullout of the individual reinforcing elements at different levels within the reinforced block should be checked in accordance with the guidelines given in Section 7.5.4(2).

(3) *Failure of connections.* Where facing elements are provided the connection between a facing element and a reinforcing element at different levels should be designed to withstand the design tension at those levels. The design of the facing connections should be in accordance with the guidelines given in Section 7.9.

(4) *Rupture of facing element.* Where facing elements are provided, the slope facing should be designed in accordance with the guidelines given in Section 7.10.

## **8.5 Compound Stability**

Similar to reinforced fill structures, the compound failure mechanisms illustrated in Figure 30 are relevant for the design of reinforced fill slopes. In assessing the potential failure modes, the guidelines given in Section 7.6 should be followed.

## **8.6 Serviceability Considerations**

Reinforced fill slopes can generally tolerate a fair degree of deformation and differential settlement. Provided that the serviceability condition of a reinforced fill slope is not sensitive to slope deformation and due account has been taken to allow for long term strain of the reinforcing elements in assessing their design strength, a serviceability limit state check is not required.

Where a serviceability limit state check is needed, the guidelines given in Section 7.7 should be followed.

## **8.7 Spacing of Reinforcement**

In determining the arrangement and layout of the reinforcement in slopes, the general guidelines given in Section 7.8 should be followed. For ease of construction, the minimum practical vertical spacing for the reinforcement could be a multiple of the appropriate fill lift, which is normally controlled by compaction considerations. Fill lifts between 150 mm and 300 mm are typical. Maximum vertical reinforcement spacing should be limited to 1.0 m. This recommendation stems from practical reasons of local face stability (i.e. ravelling of the non-structural slope face) with widely spaced reinforcement layers.

Reinforced fill slopes are frequently constructed using planar sheet or grid reinforcement. In order to maintain a uniform spacing compatible with the construction the strength of the reinforcement may be reduced as the tension in reinforcing layers reduces towards the crest of the structure.

## **8.8 Design Detailing**

### **8.8.1 Facing Details**

Adequate protective measures should be provided to ensure local stability at the slope face (i.e. prevent ravelling and surface erosion of the slope face). The gradient of the slope normally determines the types of protective measure to be employed. It is usually necessary to provide some form of facing for steep (say, 50° to 70°) slopes to enable anchorage of the reinforcement in the yielding zone and to provide erosion protection. This may consist of wrapped around flexible facing or other forms of hard facing. The selection of facing types should follow the guidelines given in Chapters 2 and 4.

For less steep (say, less than 50°) slopes it is usually possible to prevent ravelling and allow the establishment of vegetation for long term erosion protection with the aid of measures

such as a geosynthetic erosion mat together with lighter intermediate layers of reinforcement between the main reinforcement.

### **8.8.2 Drainage Details**

The drainage principles used for reinforced fill walls are applicable to reinforced fill slopes, see Section 7.11, Section 11.2.5 and Figure 43(b). Zero pore water pressure within the reinforced block may be assumed if adequate drainage measures are incorporated in the design.

[Amd GG6/01/2017]

## 9 Aesthetics and Landscaping

### 9.1 General

The aesthetics and landscaping of reinforced fill structures and slopes should be considered as an integral part of the design. The engineering and the aesthetic elements of the design should be integrated and the aesthetic and landscape objectives identified at an early stage of the project. Detailed technical guidance on good practice for the aesthetic design of slope and retaining walls, and on relevant principles of landscape design and implementation can be found in GEO Publication No. 1/2011 (GEO, 2011). [Amd GG6/01/2017]

The aesthetics and landscaping of reinforced fill features can be either by soft or hard landscape treatment, or by a combination of both. Soft landscape treatment comprises principally a vegetation cover, such as hydroseeding and planting that compliment with the surrounding vegetation. Hard landscape treatment uses concrete panels, masonry blocks or even steel or plastic claddings of various surface finishes arranged in appropriate patterns. In comparison to conventional retaining structures, reinforced fill features are constructed with prefabricated elements, therefore allowing greater flexibility in integrating different treatments to achieve innovative and practical aesthetic design solutions.

Efforts should be made to blend the reinforced fill features into their surroundings in order to create harmony between the artificial and natural landscape. Special attention should also be given to proper design detailing, construction practice and subsequent maintenance.

### 9.2 Design Detailing

Good design detailing is essential to good aesthetic design of reinforced fill features. If a project involves a number of reinforced fill features to be designed by different designers, design objectives and requirements including overall architectural appearance, design detailing and finishes should be stipulated at the preliminary design stage to ensure harmony in the feature appearance.

Robust design details should be developed, based where possible on past construction and maintenance experience. Design detailing which requires particular consideration includes:

- (a) *Joints*. Reinforced fill structures are often formed using precast units as facing. The provision of facing elements manufactured to close tolerances is important if joints are to be uniform and regular. All joints between facing units should be sealed to prevent loss of fines.
- (b) *Parapets*. Parapets attached to the reinforced fill facing should be avoided because they could restrict horizontal displacement of the wall facing which may lead to cracking of the precast facing units. Clearance between parapets and the facing should be of sufficient size to accommodate uneven alignment of the facing and any post construction displacement of the facing.



- (c) *Drainage.* Surface drainage systems should be detailed so that maintenance can be undertaken without difficulty. Surface water channels provided along the crest and the intermediate tiers of a reinforced fill structure should be of sufficient gradient to allow the channel to be self-cleansing. Such measures could minimize "overtopping" during periods of intense rainfall, hence, minimizing the staining of the wall face.
- (d) *Concrete finishes.* Facing panels with good weathering characteristics that are compatible with the particular design requirements or site conditions should be selected.
- (e) *Cracking of facing units.* Adjacent facing panels are usually located and held in place using dowels or alignment pins. This can be an area of cracking if the panels are not sufficiently robust relative to the size and stiffness of the dowels or pins.
- (f) *Joints between reinforced fill structure and cast-in-place structure.* The provision of an overlapping movement joint between a reinforced fill structure and a cast-in-place structure (see Figure 53(c)) is effective in disguising the effects of differential settlement between the structures. However, clearance between the two structures should be of sufficient size to accommodate the anticipated horizontal displacement of the facing units of the reinforced fill structure during and after construction.

Reinforced fill features, constructed using either the wrap-around technique or in conjunction with erosion control matting on the surface, can be used to support climber or groundcover vegetation on slopes of up to 60°. For steeper slopes, facing units can be used to form retaining structures in a terraced arrangement.

The exposed surface of large reinforced fill structures may not be aesthetically pleasing and can be improved by the use of vegetation. Climbers or creepers planted along the toe of the reinforced fill structures have been successfully used to mitigate visual impact.

### **9.3 Construction Practice**

The construction of reinforced fill structures and slopes needs to be carefully planned and implemented in order to achieve aesthetically pleasing results. Particular care should be taken to ensure that the facing units are not damaged during installation. The placement and compaction of fill behind the facing units should be carefully controlled to ensure that the alignment of the units is not adversely affected. The method of placement, mode of temporary support and the compaction method should be carefully planned in advance before the commencement of works.

Movement of facing units can occur during fill placement and compaction and the use of vibrating compaction equipment should be closely monitored to prevent the plant from damaging the facing units. Experience shows that sustained vibration at one location, even up to 2 m away from the facings, can cause bulging of some types of facings.

In order to prevent staining of the wall face during construction, surface runoff should not be allowed to enter the unfinished structure or "overtopping" the structure. The last level of fill material at the end of each day's work should be sloped away from the wall to direct surface water to run rapidly away from the wall face. Staining of the precast concrete facing elements can occur if they come in contact with mud or rusty reinforcement during storage and construction. Permanent marks on facing panels can be caused during storage, in particular curing marks resulting from the use of porous blocks to stack facing units.

Ill-fitting parapets or parapets displaying differential settlements may be eliminated by delaying the construction of the parapet until after construction settlements are completed. If settlement is expected to continue for a period after construction of the reinforced fill block, erection of the parapet should be undertaken at a later stage of the construction programme.

#### 9.4 Long-term Aesthetic Appearance

Reinforced fill features require regular maintenance to maintain an acceptable long-term aesthetic appearance. In addition to the requirements stipulated by Geoguide 5 (GEO, 2021), routine maintenance procedures should consider the following items:

[Amd GG6/01/2017]

[Amd GG6/01/2022]

- (a) *Leaking joints.* Rectification of leaking joints between facing units may be difficult and require careful investigation to determine the source of the problem. Localised sealing of a leaking joint may not be entirely effective in the long-term. Preventive actions are preferred, such as provision of drainage layer behind the facing units or routing of water-carrying services away from the reinforced fill body.
- (b) *Cracking and staining of facing.* Cracking and staining of the facing discovered during routine inspection should be rectified without delay to prevent further deterioration.
- (c) *Unplanned vegetation.* Unplanned vegetation could seriously affect the appearance of reinforced fill features and cause structural damage, particularly when plants take root at the panel joints. Regular pruning should be specified in the maintenance manual if soft landscape treatment is employed. Planting of trees should not be permitted behind the facing units as the tree roots may damage the reinforcing elements or displace the facing units.

## **10 Procurement and Specification**

### **10.1 General**

A wide range of reinforced fill systems have been developed and these offer engineering solutions that can be more advantageous than conventional forms of retaining wall construction or embankment construction (see Chapter 2). Reinforced fill options should be considered at the design stage of a project, i.e. an Engineer's design in which all design considerations would be taken into account fully.

### **10.2 Contract and Specification**

#### **10.2.1 Types of Contract**

Two basic contractual arrangements may be adopted for a project involving reinforced fill structures or slopes. These are:

- (a) conventional contracts, such as lump sum contract or re-measurement contract, and
- (b) design and build contract.

#### **10.2.2 Conventional Contract**

In the conventional contract, the design is carried out by the employer and all the details of the required reinforced fill structures or slopes are given in the contract drawings or specification. To give the contractor the widest choice, thereby minimizing costs, the contract should permit the use of alternative reinforced fill products, including the choice of fill materials.

#### **10.2.3 Design and Build Contract**

An alternative to the conventional contract is the design and build contract, which is also suitable for the procurement of reinforced fill design and construction. In this case, if the Employer wishes to obtain competitive bids for the various reinforced fill systems available, he can call for a design by the contractor which incorporates the contractor's choice of reinforcement, facings, etc. It would be appropriate to request the tenderers to submit a scheme of preliminary design at the tender stage for assessment. Such a requirement should be stipulated in the Condition of Tender.

The tender documents should incorporate the following:

- (a) The requirement that the design should be in accordance with the provisions of this Geoguide with respect to both the specification of materials and construction requirements, and acceptable standards of design.

- (b) Specification of the minimum details which should be included with the tender to allow the employer to make a decision as to the acceptability of the design. These details should include at least a dimensioned plan and sections, the name of the system or types of reinforcing elements and facings to be used and preliminary design calculations that support the feasibility of the proposal.
- (c) Special conditions of contract and employer's requirements to cover the following:
- scope of the design and design responsibility,
  - independent design checking and supervision of construction,
  - acceptance testing,
  - maintenance period and maintenance requirements, and
  - method of payment and patent rights and royalties.

A "design and build" situation may also arise where the contractor is given a choice or wishes to propose a reinforced fill alternative to a specified structure. In this case, the contractor should be required to submit the proposal in compliance with the above requirements.

#### **10.2.4 Model Specification**

A model specification for the provision of reinforced fill structures and slopes in Hong Kong is given in Appendix A. The model specification can be incorporated as a particular specification in the contract documents. The clauses may need to be modified to suit individual users requirements.

### **10.3 Suitability of Contractors**

Contractors who are competent and experienced in civil and geotechnical engineering works such as site formation works, retaining structures and slope stabilization works should be suitable to undertake reinforced fill construction.

Problems with the construction of reinforced fill structures have occurred when a contractor, inexperienced in this form of construction, relies upon the experience of subcontractors without supervision and ensuring integration with the rest of the works. The experience of the contractor for design and construction of reinforced fill structures and slopes should be stipulated in the contract as a requirement.

At the tender stage, it would be appropriate to request the tenderers to submit as part of the tender assessment a list of contracts in which they are responsible for the design and construction of reinforced fill structures and slopes. Prequalification of the tenderers could also be carried out to ensure the quality and experience of the contractor.

#### **10.4 Patents and Client's Indemnification**

Many of the original reinforced fill patents have expired but certain reinforced fill systems and components are still covered by patents, and tender and contract documentation should contain suitable clauses to ensure no unforeseen liabilities are incurred with respect to their use. The contract document should require the tenderer or contractor using the reinforced fill technique to indemnify the employer against any claims which might arise from patent or copyright violation.

Where the contract documents call for a contractor's design of reinforced fill structures or slopes, or where they allow alternative design based on the use of the reinforced fill technique, the responsibility for obtaining and maintaining all necessary licences or permission to make use of relevant patent rights, design trade marks or names or other protected rights, and for payment of fees and royalties in respect of any patents or licences which may exist, should be placed on the contractor. The conditions of contract should include appropriate clauses to clearly define this responsibility.

Where a contract incorporates a reinforced fill structure or slope in which the reinforcing elements, facings and connections are designed by the employer, rather than utilising a proprietary system, the designer should ensure that existing patents are not violated.

## **11 Construction Control**

### **11.1 General**

The construction control for reinforced fill structures and slopes is similar to that for any site formation project comprising large fill embankments or platforms, except that additional planning considerations for supply, storage, installation and testing of prefabricated components of the reinforced fill features are necessary. Special attention must also be given to locating a source of suitable fill material.

Proper supervision and control are required during all stages of the work, including storage and handling of facing units and reinforcing elements, excavation of foundations, compaction of fill material, erection of facing panels, placement of reinforcing elements and provision of temporary supports and temporary drainage. Site supervisory staff responsible for ensuring the quality of materials and workmanship under the works contract should include adequate geotechnical personnel for the supervision of the works.

Assumptions critical to the design of reinforced fill features (such as the foundation and groundwater models) should be reviewed during construction by the designer. Often the best time to carry out the design review and to confirm the ground conditions is when the ground is exposed at various stages of construction. Attention should be given to assessing the influence of variations in the foundation and groundwater conditions on the design of the reinforced fill feature.

Detailed guidance on the aspects of construction control which are directly related to verification of the geotechnical design assumptions is outlined in Chapter 12 of Geoguide 1 (GEO, 2020). Further guidance relevant to reinforced fill structures and slopes are covered in this Chapter. [Amd GG6/01/2022]

### **11.2 Construction Supervision**

#### **11.2.1 General**

The site supervisory staff should be aware of the requirements with respect to the construction of reinforced fill features. Good communication should always be maintained between the designer and the site staff. Frequent site visits and discussions with the site staff commensurate with the size and complexity of the project should be made by the designer.

At the commencement of the contract, the site supervisory staff should be made aware of the critical construction activities, any additional ground investigation needed and the need for verification of the geotechnical design assumptions. Where the assumptions are not met or where information critical to the verification of design assumptions is revealed on site, the designer should be informed so that site inspections and any necessary design modifications can be made promptly. Both design verification and contract compliance testing requirements should be identified early. Arrangements should be put in place by the site supervisory staff shortly after commencement of the works to ensure sufficient lead time for design verification testing and adequate and timely supervision of any field investigation and tests required.

In some projects, e.g. those involving high or large-scale reinforced fill features constructed in difficult ground conditions, there could be a need to have a professionally qualified and suitably experienced geotechnical engineer (e.g. Registered Professional Engineer (Geotechnical)) resident on site to supervise critical construction activities and undertake design review. General guidance on the level of geotechnical supervision for works which could pose a high risk to life or property is provided in Table 21 of Geoguide 1 (GEO, 2020). [Amd GG6/01/2022]

A risk assessment should be carried out for projects involving site formation which may be vulnerable to severe rainfall events causing adverse landslide impacts on the public in case of uncontrolled overflow of surface water towards slopes, retaining walls and other features. This should include an assessment of the drainage-related hazards on slope safety when the site is affected by rainfall which exceeds the design event. If necessary, a risk management plan incorporating measures to manage the landslide risk, including any necessary precautionary and mitigation measures at different stages of construction, should be put in place to prevent adverse effects of overflow of surface water on slope safety when the capacity of the temporary drainage provisions is overwhelmed. The plan should contain, inter alia, the location of standby plant and equipment, the persons who will monitor the weather conditions and implement the measures when required (including outside working hours), and the emergency contact details of key personnel. [Amd GG6/01/2017]

A checklist providing general questions that may need to be addressed when constructing a reinforced fill structure or slope is given in Appendix B. The checklist should be suitably modified to suit individual situations and contract requirements.

### 11.2.2 Pre-construction Review

Prior to the commencement of construction, the site staff responsible for supervising the construction of the reinforced fill features should acquaint themselves with the design, and in particular the following items:

- (a) contract drawings and specifications,
- (b) available ground investigation records and geotechnical design report,
- (c) site conditions and sources of suitable fill materials,
- (d) material requirements, construction tolerances and the acceptance/rejection criteria,
- (e) construction procedures and sequence,
- (f) details of fill compaction requirements including the thickness of compacted fill layers and capacities and weights of the compaction equipment,

- (g) details of all necessary temporary works for construction including the method of supporting the facing units during construction,
- (h) placement and storage requirements to reduce construction damage of the facing elements and reinforcement,
- (i) corrosion protection systems for metallic reinforcement,
- (j) details of drainage requirements and services, and
- (k) details of any construction measurements required and long term monitoring.

### **11.2.3 Construction Method and Sequence**

Selection of the method and sequence of construction is usually undertaken by the contractor. However, there may be instances where a particular method or sequence of operations is dictated by the design. In such cases, the designer may stipulate the methods of construction. In all cases, there should be suitable controls, e.g. by requiring the submission of method statements, so that an assessment can be made during construction.

The processes of excavation, dewatering, filling, etc. should be so arranged as not to adversely affect the stability of any portion of the reinforced fill feature, including any partially completed sections. The site supervisory staff should be aware of the tolerances of the completed structure. The designer should ensure that the construction method and sequence proposed by the contractor can take account any movements which may occur during construction (e.g. due to compression of the reinforced fill mass and settlement of the foundation).

The submission requirements relating to the contractor's method statements are specified in Clauses A.17-A.21 of the Model Specification in Appendix A.

### **11.2.4 Preparation of Foundation**

The excavation for the foundation of a reinforced fill feature should be protected from the effects of traffic, exposure to weather (rain and drying conditions) and the action of water (flow or ponding of surface water). As blinding concrete is usually not placed for reinforced fill features, backfilling of foundations that are susceptible to deterioration should take place as soon as possible. In addition, any loose debris or slurry at the foundation level must be removed prior to commencement of backfilling.

Additional excavation is usually required to provide for the strip footing of the facing units. It is advisable to have the width of the excavation for the strip footing at least 120 mm wider than the thickness of the facing units, so that a sufficiently wide foundation is available to adjust the facing to the required alignment.



The requirements for the preparation of foundation are specified in Clause A.25 of the Model Specification in Appendix A.

### **11.2.5 Temporary Drainage**

Drainage is an important consideration for reinforced fill features. A reinforced fill feature should not be allowed to become water-logged since this will adversely affect its stability. In Hong Kong, there have been cases where inadequate temporary surface water drainage has led to failure of reinforced fill structures during construction, resulting in expensive remedial works (Raybould et al, 1996; Lam et al, 2001b; FSWJV, 2013). In these cases, constructions were carried out on sloping terrain during the wet season and due to inadequate temporary surface water drainage provisions, the filling areas were severely flooded. The rapid rise in water levels led to heavy seepage through the facing panels and the washing out of the backfill of the partially completed structures. Dislodgment of the panels caused escalation of the process and major displacements of the facing panels occurred when the toe supports of the structures were undermined by further erosion. It is also noted that the internal detailing of the distressed reinforced fill structure is vulnerable to piping in the event of significant water ingress into its drainage layers which were not sealed off during construction (FSWJV, 2013).

[Amd GG6/01/2017]

These failures demonstrate that adequate temporary surface water drainage must be provided to divert the surface runoff away from the construction area. Where the area crosses existing drainage/stream courses, temporary diversion of the surface water will be necessary during construction. The effect of the temporary flow on slope stability and existing and temporary drainage measures should be assessed. In addition, inspection of the proper functioning of the temporary drainage should be undertaken during construction and particularly during and immediately after heavy rainfall.

Temporary drainage plans should be updated in a timely manner to suit the site conditions during construction. Adequate drainage provisions shall be maintained on site at all times, including during the period when the temporary drainage works are being re-routed or re-constructed in accordance with any updated temporary drainage plans to suit various stages of construction.

[Amd GG6/01/2017]

Specifically the integrity and stability of a reinforced fill structure during construction are particularly vulnerable to excessive water ingress. Adequate temporary drainage provisions and precautionary and mitigation measures should be implemented to prevent excessive water ingress into the reinforced fill structure not allowed for in the design and thereby overwhelming its drainage capacity, causing distress or structure instability.

[Amd GG6/01/2017]

### **11.2.6 Storage and Installation of Facing and Reinforcing Elements**

Care must be taken to ensure that facing and reinforcing elements are not damaged during storage and construction. Polymeric reinforcement will deteriorate if they are left exposed to sunlight and the weather. They should be properly protected (e.g. wrapped with opaque polythene covering material) until they are required for installation.

In Hong Kong, incorrectly placed reinforcement has led to failure of a reinforced fill slope, resulting in expensive remedial works. In this case, the reinforcement were not extended to the slope face as the slope was overfilled and trimmed back to the final profile. The site supervisory staff responsible failed to realize that the reinforcement were curtailed 2 m from the slope face. Shallow failures occurred during heavy rainfall shortly after the completion of the slope. This failure demonstrates that in using the overfill and cut back technique to ensure proper compaction of the slope face, site supervisory staff should ensure that the reinforcement are exposed after the cutting back of the slope face.

In the installation of reinforcement, care must be taken to ensure the correct orientation of the reinforcement. For reinforced fill wall or slope, the primary direction of tensile strength should be placed perpendicular to the wall facing or slope face. Incorrectly placed polymeric reinforcement could lead to failure of reinforced fill features.

The requirements for the handling and installation of facing and reinforcing elements are specified in Clauses A.22-A.24 and Clauses A.26-A.29 of the Model Specification in Appendix A.

### **11.2.7 Deposition and Compaction of Fill and Filter/Drainage Layers**

The method of deposition and compaction of fill material is similar to that for any earthworks. General guidance on compaction of fill material can be found in the Geotechnical Manual for Slopes (GEO, 1984). Where elemental facing units are used, the deposition of fill material follows closely the erection of each of facing units. The fill material should be deposited, spread, levelled and compacted in horizontal layers, using methods appropriate to the fill material and the earthworks equipment used. Care should be taken to ensure that adequate compaction is achieved throughout the fill mass and, in particular, that no voids exist directly beneath reinforcing elements. Experience has shown that, if the thickness of the compacted layers is between 150 mm and 300 mm but not less than 1.5 times the maximum particle size, adequate compaction can normally be achieved uniformly.

It is important to select the thickness of layers to be compacted so that each layer of reinforcing elements can be fixed on top of the finished surface of the compacted layer. Trial compaction to determine the layer thickness for given compaction plant is recommended. For steel reinforcing elements, there should be a minimum separation of 100 mm between the reinforcement to avoid any risk of 'bonding' which may arise due to corrosion products deposited in the fill material. The formation of such bonds will result in accelerated electrolytic action.

During compaction, or when moving earthworks equipment or machinery on top of the fill, care should be taken not to damage or displace the structural elements in the reinforced fill block. The use of vibrating compaction equipment should be closely supervised to prevent the plant from stopping adjacent to the facing units while it is still vibrating. Sustained vibration at one location, even up to 2 m away from the facings, can cause bulging of some types of facings. Moreover, all vehicles and all construction equipment weighing more than 1000 kg should be kept at least 1.5 m away from the face of the structure.

The requirements for the deposition and compaction of backfill and filter/drainage layers are specified in Clauses A.30-A.33 of the Model Specification in Appendix A.

### **11.2.8 Testing of Materials**

The materials used for the construction of the reinforced fill structure or slope should be inspected and tested on a regular basis. Testing is required to ensure that the material conforms to the specification.

The potential sources of selected fill material should be identified at the early stage of the contract. Testing takes time and hence should be arranged as early as possible to ensure the selected fill materials are in compliance with the specification.

Particular attention should be given to materials which can change properties; these include reinforcing elements and fill. Fill from different sources may have different material parameters and should be checked for compliance. Some forms of reinforcement are difficult to distinguish from each other. Each main delivery of reinforcement should be sampled, tested and properly labelled.

The requirements for the testing of materials are specified in Clauses A.36-A.68 of the Model Specification in Appendix A.

## References

- APHA (1992). *Standard Methods for the Examination of Water and Wastewater (18<sup>th</sup> Edition)*. American Public Health Association, Washington DC.
- ASTM (2001). *Standard Test Method for Microscopic Evaluation of the Dispersion of Carbon Black in Polyolefin Geosynthetics (ASTM D 5596-94)*, 3 p.
- Bagir, T. (1944). *Iraq Journal*, pp 5-6, British Museum.
- Bassett, R.N. & Last, N.C. (1978). Reinforced earth below footings and embankments. *Proc. ASCE Speciality Conference*, Pittsburgh.
- BD (2020). *Code of Practice for Structural Use of Concrete (revision : December 2020)*. Buildings Department, Hong Kong, 198 p.  
[Amd GG6/01/2017]  
[Amd GG6/01/2022]
- BD (2021). *Code of Practice for the Structural Use of Steel (revision : August 2021)*. Buildings Department, Hong Kong, 367 p.  
[Amd GG6/01/2017]  
[Amd GG6/01/2022]
- BSI (1968). *Specification for Metal Washers for General Engineering Purposes. Metric Series (BS 4320 : 1968)*. British Standards Institution, London.  
[Amd GG6/01/2017]  
[Amd GG6/01/2022]
- BSI (1991). *Steel Plate, Sheet and Strip. Carbon and Carbon-Manganese Plate, Sheet and Strip. General Specification (BS 1449: Part 1 : 1991)*. British Standards Institution, London.
- BSI (1993). *Methods of Testing Plastics. Chemical Properties. Determination of Carbon Black Content of Polyolefin Compound (BS 2782-4 : Method 452B : 1993)*. British Standards Institution, London.  
[Amd GG6/01/2017]  
[Amd GG6/01/2022]  
[Amd GG6/01/2017]  
[Amd GG6/01/2022]  
[Amd GG6/01/2017]  
[Amd GG6/01/2022]
- BSI (2004a). *Eurocode 2: Design of Concrete Structures - Part 1-1: General Rules and Rules for Buildings (BS EN 1992-1-1:2004)*. British Standards Institution, London, 230 p.  
[Amd GG6/01/2017]
- BSI (2004b). *Geotextiles and geotextile-related products - Determination of pullout resistance*

- in soil (BS EN 13738:2004)*. British Standards Institution, London, 18p. [Amd GG6/01/2022]
- BSI (2004c). *Hot Rolled Products of Structural Steels - Part 1: General Technical Delivery Conditions (BS EN 10025-1:2004)*. British Standards Institution, London, 36 p.  
[Amd GG6/01/2017]  
[Amd GG6/01/2022]  
[Amd GG6/01/2022]
- BSI (2005a). *Steel Fabric for the Reinforcement of Concrete - Specification (BS 4483:2005)*. British Standards Institution, London, 18 p. [Amd GG6/01/2017]
- BSI (2005b). *Steel Wire for the Reinforcement of Concrete Products - Specification (BS 4482:2005)*. British Standards Institution, London, 30 p. [Amd GG6/01/2017]
- BSI (2006). *Cold Rolled Low Carbon Steel Flat Products for Cold Forming – Technical Delivery Conditions (BS EN 10130:2006)*. British Standards Institution, London, 16 p.  
[Amd GG6/01/2017]  
[Amd GG6/01/2022]  
[Amd GG6/01/2017]  
[Amd GG6/01/2022]  
[Amd GG6/01/2022]
- BSI (2008). *Geosynthetics - Tensile Test for Joints/Seams by Wide-width Strip Method (ISO 10321:2008) (BS EN ISO 10321:2008)*. British Standards Institution, London, 20 p.  
[Amd GG6/01/2017]  
[Amd GG6/01/2022]
- BSI (2009). *Hot Dip Galvanized Coatings on Fabricated Iron and Steel Articles - Specifications and Test Methods (ISO 1461:2009) (BS EN ISO 1461:2009)*. British Standards Institution, London, 24 p.  
[Amd GG6/01/2017]  
[Amd GG6/01/2022]  
[Amd GG6/01/2022]
- BSI (2010). *Code of Practice for Strengthened/Reinforced Soils and Other Fills (BS 8006-1:2010)*. British Standards Institution, London, 260 p. [Amd GG6/01/2017]  
[Amd GG6/01/2022]
- BSI (2014a). *ISO Metric Precision Hexagon Bolts, Screws and Nuts. Specification (BS 3692 : 2014)*. British Standards Institution, London. [Amd GG6/01/2022]
- BSI (2014b). *ISO Metric Black Hexagon Bolts, Screws and Nuts. Specification (BS 4190 : 2014)*. British Standards Institution, London. [Amd GG6/01/2022]
- BSI (2015). *Geosynthetics - Wide-width Tensile Test (ISO 10319:2015) (BS EN ISO 10319: 2015)*. British Standards Institution, London, 18 p.  
[Amd GG6/01/2017]  
[Amd GG6/01/2022]

- BSI (2016a). *Steel for the Reinforcement of Concrete - Weldable Reinforcing Steel - Bar, Coil and Decoiled product - Specification (BS 4449: 2005+A3: 2016)*. British Standards Institution, London, 34 p. [Amd GG6/01/2017]  
[Amd GG6/01/2022]
- BSI (2016b). *Test Sieves. Technical Requirements and Testing. Test Sieves of Metal Wire Cloth (BS ISO 3310-1: 2016)*. British Standards Institution, London. [Amd GG6/01/2017]  
[Amd GG6/01/2022]
- BSI (2019a). *Concrete - Complementary British Standard to BS EN 206-1 - Part 1: Method of Specifying and Guidance for the Specifier (BS 8500-1: 2015 +A2: 2019)*. British Standards Institution, London, 66 p. [Amd GG6/01/2017]  
[Amd GG6/01/2022]
- BSI (2019b). *Concrete - Complementary British Standard to BS EN 206-1 - Part 2: Specification for Constituent Materials and Concrete (BS 8500-2: 2015 +A2: 2019)*. British Standards Institution, London, 52 p. [Amd GG6/01/2017]  
[Amd GG6/01/2022]
- BSI (2019c). *Hot Rolled Products of Structural Steels - Part 2: Technical Delivery Conditions for Non-alloy Structural Steels (BS EN 10025-2: 2019)*. British Standards Institution, London, 38 p. [Amd GG6/01/2017]  
[Amd GG6/01/2022]
- BSI (2019d). *Metallic Materials - Tensile Testing, Part 1: Method of Test at Ambient Temperature (BS EN ISO 6892-1: 2019)*. British Standards Institution, London, 76 p. [Amd GG6/01/2017]  
[Amd GG6/01/2022]
- BSI (2021a). *Concrete - Part 1: Specification, Performance, Production and Conformity (BS EN 206: 2013 + A2: 2021)*. British Standards Institution, London, 74 p. [Amd GG6/01/2017]  
[Amd GG6/01/2022]
- BSI (2021b). *Methods of Test for Soils for Civil Engineering Purposes. Chemical and Electro-Chemical Tests (BS 1377-3: 2018 + A1: 2021)*. British Standards Institution, London. [Amd GG6/01/2022]  
[Amd GG6/01/2017]
- Cassard, A., Kern, F. & Mathieu, G. (1979). *Use of Reinforcement Technique in Earth Dam*. C.R. Coll. Int. Reinforcement Des Sols, Paris.
- CIRIA (1996). *Soil Reinforcement with Geotextiles*. CIRIA Special Publication 123, p 332, Thomas Telford.
- Department of Transport (1977). *Reinforced Earth Retaining Walls for Embankments Including Abutments*. Tech. Mem. BE (Interim), Dept. of Environment, Highways Directorate.
- Duncan, W. (1855). *Caesar*. Harper Brothers, New York.

- ECGL (1989). *Designing for Soil Reinforcement*. Exxon Chemical Geopolymers Ltd, Design Manual, UK.
- Eyre, D. & Lewis, D.A. (1987). *Soil Corrosivity Assessment*. TRRL Contractor Report CR54, Crowthorne.
- Federal Highway Administration (FHWA) (1997). *Mechanically Stabilized Earth Walls and Reinforced Soil Slopes*. Design and Construction Guidelines, FHWA Demonstration Project 82, Publication No. FHWA-SA-96-071, 317 p, Washington DC.
- Findlay, T.W. (1978). Performance of a Reinforced Earth Structure at Ganton. *Ground Engg.*, vol. 2, no. 7, pp 42-44.
- Fraser, J.B. (1962). *A Steel-faced Rockfill Dam for Papua*. Trans. Inst. of Engrs., Australia, CE4.
- FSWJV (2013). *Report on the 22 May 2013 Distress at a Reinforced Earth Wall at a Construction Site above Shun On Road, Sau Mau Ping*. Fugro Scott Wilson Joint Venture, 86 p. [Amd GG6/01/2017]
- GEO (1984). *Geotechnical Manual for Slopes (Second edition)*. Geotechnical Engineering Office, Civil Engineering and Development Department, HKSAR Government, 302 p. [Amd GG6/01/2022]  
[Amd GG6/01/2022]  
[Amd GG6/01/2017]  
[Amd GG6/01/2022]
- GEO (2011). *Technical Guidelines on Landscape Treatment for Slopes (GEO Publication No. 1/2011)*. Geotechnical Engineering Office, Hong Kong, 217 p. [Amd GG6/01/2017]
- GEO (2017a). *Guide to Site Investigation (Geoguide 2) (Continuously Updated E-Version Released on 18 December 2017)*. Geotechnical Engineering Office, Civil Engineering and Development Department, HKSAR Government, 349 p. [Amd GG6/01/2022]
- GEO (2017b). *Model Specification for Soil Testing (Geospec 3) (Continuously Updated E-Version Released on 29 August 2017)*. Geotechnical Engineering Office, Civil Engineering and Development Department, HKSAR Government, 324 p. [Amd GG6/01/2017]  
[Amd GG6/01/2022]
- GEO (2020). *Guide to Retaining Wall Design (Geoguide 1) (Continuously Updated E-version Released on 1 June 2020)*. Geotechnical Engineering Office, Civil Engineering and Development Department, HKSAR Government, 245 p. [Amd GG6/01/2017]  
[Amd GG6/01/2022]
- GEO (2021). *Guide to Slope Maintenance (Geoguide 5, Third Edition) (Continuously Updated E-version Released on 25 November 2021)*. Geotechnical Engineering Office, Civil Engineering and Development Department, HKSAR Government, 122 p. [Amd GG6/01/2017]  
[Amd GG6/01/2022]

- Grassie, N. & Scott, G. (1985). *Polymer Degradation and Stabilisation*. Cambridge University Press.
- HKSARG (2018). *Construction Standard, Steel Reinforcing Bars for the Reinforcement of Concrete (CS2:2012) (Continuously Updated E-version Released on 26 September 2018)*. HKSAR Government, 53 p. [Amd GG6/01/2017]  
[Amd GG6/01/2022]
- Holloway, L. (1990). *Polymers and Polymer Composites in Construction*. Thomas Telford, London, p 275.
- Hong Kong Observatory (2002). *Soil Temperature Measurement at Hong Kong Observatory from 1978-2002*. Unpublished data.
- Jailloux, J.M. & Anderson, P. (1996). *Long Term Testing of Polyester Yarn and Product at 50°C and 23°C in Different Environments*. IS Kyushu 96, Balkema.
- Janbu, N. (1973). Slope stability computations. *Embankment Dam Engineering: Casagrande Volume* (eds. Hirshfield & Poulos), John Wiley & Sons, New York, pp 47-86.
- Jewell, R.A. (1980). *Some Effects of Reinforcement to the Mechanical Behaviour of Soils*. PhD Thesis, University of Cambridge.
- Jewell, R.A. (1985). Material Properties for the Design of Geotextile Reinforced Slopes. *Geotextiles and Geomembranes*, vol. 2, pp 83-109, Elsevier.
- Jewell, R.A. (1990). *Revised Design Charts for Steep Reinforced Slopes*. Theory and Practice in the British Isles, Thomas Telford, UK, pp 1-31.
- Jewell, R.A., Paine, N. & Woods, R.I. (1985). *Design Methods for Steep Reinforced Embankments*. Polymer Grid Reinforcements, Thomas Telford, London, pp 70-81.
- Jones, C.J.F.P. (1978). *The York Method of reinforced earth construction*. *ASCE Symposium on Earth Reinforcement*, pp 501-528, Pittsburg.
- Jones, C.J.F.P. (1979). *Lateral Earth Pressures Acting on the Facing Units of Reinforced Earth Structures*. C.R. Coll. Int. Reinforcement des Sols, pp 445-451, LCPC, Paris.
- Jones, C.J.F.P. (1996). *Earth Reinforcement and Soil Structures*. Thomas Telford, p 379.
- Jones, C.J.F.P., Cripwell, J.B. & Bush, D.I. (1990). Reinforced earth trial structure for Dewsbury Bypass. *Proc. Inst. Civ. Engrs.*, Part 1, April, vol. 88, pp 321-345.
- Jones, C.J.F.P., Fakher, A., Hamir, R. & Nettleton, I.M. (1997). Geosynthetic materials with improved reinforcement capabilities. *Earth Reinforcement* (eds. Ochiai, Yasufuku and Omine), vol. 2, pp 865-887, Balkema.
- Jones, C.J.F.P. & Sims, F.A. (1975). Earth pressures against the abutments and wingwalls of standard motorway bridges. *Geotechnique*, vol.23, no.4, pp 515-530.



- Jones, C.J.F.P. & Spencer, W.J. (1978). *The Implications of Mining Subsidence for Highway Structures*. In Large Ground Movement and Structures (ed. Geddes), Pentech Press, UK, pp 515-526.
- Jones, C.J.F.P. & Templeman, J. (1979). *Soil Structures Using High Tensile Plastic Grids (tailed gabions)*. UK Patent No. 794/627.
- Kempton, G.T., Jones, C.J.F.P., Jewell, R.A. & Naughton, P.J. (2000). Construction of Slopes Using Cohesion Fills and a New Innovative Geosynthetic Material. *2nd European Conference on Geosynthetics*, vol. 2, pp 825-828, Pation Editore, Bologna.
- King, R.A. & Nabizadeh, H. (1978). Corrosion in reinforced earth structures. *ASCE Symp. Earth Reinforcement*, p 595, Pittsburgh, USA.
- King, R.A. (1978). Corrosion in reinforced earth. *Proc. Symp Reinforced Earth and other Composite Soil Techniques. TRRL Supplementary Report 457*, pp 276-285.
- Koerner, R.M., Hsuan, Y. & Lord, A.E. (1992). *Remaining Technical Barriers to Obtain General Acceptance of Geosynthetics*. Mercer Lecture, ICE, London, p 48.
- Lam, A.Y.T., Lau, K.W.K. & Yim, K.P. (2001a). Reinforced fill applications in Hong Kong. *Conference Proceeding of International Conference on Construction*, vol. 1, pp 93-104.
- Lam, A.Y.T., Lau, K.W.K. & Lee, C.K.T. (2001b). Design and construction of a 16 m high reinforced fill retaining wall in Hong Kong. *Proceedings of the Fourteenth Southeast Asian Geotechnical Conference*, Hong Kong, Volume 1, pp 361-366.
- Lawson, C.R. (1991). Use of geotextiles in reinforced soil retaining structures. *Sydney Technological University Report*, Australia, p 44.
- Lee, K., Jones, C.J.F.P., Sullivan, W.R. & Trollinger, W. (1994). Failure and deformation of four reinforced soil walls in eastern Tennessee. *Geotechnique*, vol. 44, no. 3, pp 397-426.
- McGown, A., Murray, R.T. & Andrawes, K.Z. (1978). Influence of wall yielding on lateral stresses in unreinforced and reinforced fills. *TRRL, Research Report 113*, Crowthorne, p 14.
- Milligan, G.W.E. (1974). *The Behaviour of Rigid and Flexible Retaining Walls in Sand*. PhD Thesis, Cambridge University.
- Mitchell, J.K. & Villet, W.C.B. (1987). Reinforcement of earth slopes and embankments. *National Cooperative Highway Research Program Report 290*, Transportation Research Board, National Research Council, Washington DC, USA.
- Morgenstern, N.R. & Price, V.E. (1965). The analysis of the stability of general slip surfaces. *Geotechnique*, vol. 15, pp 79-93.
- Moulton, L.K., Gangorao, H.V.S. & Halvorsen, G.T. (1982). Tolerable movement criteria for

- highway bridges. *Report No. FHWA/RD-81/162, Federal Highway Administration, Washington DC.*
- Murray, R.T. (1977). Research at TRRL to develop design criteria for reinforced earth. *Symp. Reinforced Earth and Other Composite Soil Techniques*, Heriot-Watt University, TRRL Supplementary Report 457.
- Naylor, D.J. (1978). A study of reinforced earth walls allowing slip strip. *Symp. on Earth Reinforcement, ASCE Speciality Conf.*, Pittsburgh, pp 618-643.
- NCMA (1997). *Design Manual for Segmental Retaining Walls. (Second edition)*. National Concrete Masonry Association, USA.
- Nicu, N.D., Antes, D.R. & Kessler, R.S. (1970). Field measurements on instrumented piles under an overpass abutment. *Report to the Committee for Foundations in Bridges and Other Structures*, New Jersey Dept. of Transportation, USA.
- O'Rourke, T.D. & Jones, C.J.F.P. (1990). An overview of earth retention systems 1970-1990. *ASCE Speciality Conf. on Earth Retaining Structures*, pp 22-51, Cornell Univ.
- Palmeira, E.M. & Milligan, G.W.E. (1989). Scale and other factors affecting the results of pullout tests of grids buried in sand. *Geotechnique*, vol. 39, no. 3, pp 511-524.
- Pasley, C.W. (1822). *Experiments on Revetments Vol.2*. Murray, London.
- Raybould, M. J., Hadley, D. & Boyd, M. (1996). Design, construction and performance of a 40 m high reinforced fill in Hong Kong. *Proceedings of the International Symposium on Earth Reinforcement*, Fukuoka, Kyushu, Japan, Special Volume, pp 21-26.
- Saran, S., Talevar, D.V. & Prakesh, S. (1979). Earth pressure distribution on retaining walls with Reinforced Earth backfill. *Int. Conf. Soil Reinforcement*, Paris, vol. 1.
- Schlosser, F. & Elias, V. (1978). Friction in reinforced earth. *Proc. ASCE Symposium on Earth Reinforcement*, pp 735-763, Pittsburgh.
- Schlosser, F. (1978). Experience on reinforced earth in France. *Symp. Reinforced Earth and Other Composite Soil Techniques*, Heriot-Watt University, TRRL Supplementary Report 457.
- Schmertmann, G.R., Gouery-Curtis, V.E., Johnson, R.D. & Bonaparte, R. (1987). Design charts for geogrid-reinforced soil slopes. *Geosynthetic 87 Conference*, New Orleans, USA, pp 108-120.
- Shi, Y.C. & Swann, L.H. (2001). Use of reinforced earth (RE) wall as an alternative to a bridge viaduct at Cyberport development, Hong Kong. *Proceedings of the Fourteenth Southeast Asian Geotechnical Conference*, Hong Kong, Volume 1, pp 419-424.
- Silvestri, V. (1983). The bearing capacity of dykes and fills founded on soft soils of limited thickness. *Canadian Geotechnical Journal*, vol. 20, no. 3, pp 428-436.

- Sims, F.A. & Bridle, R.J. (1966). Bridge designs in areas of mining subsidence. *Journ. Inst. Of High. Engineers*, vol. 13, November, pp 19-34.
- Sims, F.A. & Jones, C.J.F.P. (1974). Comparison between theoretical and measured earth pressures acting on a large motorway retaining wall. *J. Inst. High. Eng.*, December, pp 26-29.
- Smith, A.K.C.S. (1977). *Experimental and Computational Investigations of Model Reinforced Earth Retaining Walls*. PhD Thesis, Cambridge University.
- Tateyama, M., Tatsuoka, F., Koseki, J. & Harii, K. (1995). Damage to soil retaining walls for railway embankments during the Great Hanskui-Aweji Earthquake, Jan. 17 1995. *1<sup>st</sup> Int. Conf. on Earthquake Geot. Eng.*, IS-Tokyo '95, Tokyo.
- Teng, W.C. (1962). *Foundation Design*. Prentice-Hall, 466 p.
- Vidal, H. (1966). *La terre armée*. Annales de L'Institut Technique du Bâtiment et des Travaux Publics, Série Matériaux 30, Supplement No.223-4, July-August.
- Walkinshaw, J.L. (1975). *Reinforced Earth Construction*. Dept. of Transportation GHWA Region 15. Demonstration Project No.18.
- Westergaard, H.M. (1938). A problem of elasticity suggested by a problem in soil mechanics. Soft material reinforced by numerous strong horizontal sheets. *Mechanics of Solids, Timoshenko 60th Ann.*, vol. 268-277, Macmillan, New York.
- Wisse, J.D.M., Broos, C.J.H. & Bochs, W.H. (1990). Evaluation of the life expectancy of polypropylene geotextiles used in bottom protection structures around the Ooster Schelde storm surge barriers. *Proc. 4<sup>th</sup> Int. Conf. on Geotextiles, Geomembranes and Related Products*, The Hague, Vol. 2, pp 697-702, Balkema.
- Worrall, P.K. (1989). *Reinforced Earth Abutments and Approach Ramps on Compressible Soils at Burton-on-Trent*. Highways & Transportation, March, pp 5-8.

Tables

**List of Tables**

Table No.		Page No.
1	Comparison of Various Types of Reinforced Fill Systems	109
2	Sacrificial Thickness to be Allowed on Each Surface of Galvanised Steel Exposed to Corrosion in Selected Fill	110
3	Recommended Partial Consequence Factors for the Design of Reinforced Fill Structures and Slopes	110
4	Typical Examples of Failures in Each Consequence-to-life Category	111
5	Typical Examples of Failures in Each Economic Consequence Category	112
6	Recommended Partial Material Factors for the Design of Reinforced Fill Structures and Slopes	113
7	Recommended Partial Load Factors for the Design of Reinforced Fill Structures and Slopes	114
8	Recommended Partial Load Factors for Load Combinations for Reinforced Fill Retaining Walls and Bridge Abutments	114
9	Tolerance of Reinforced Fill Facing Systems to Differential Settlement	115
10	Minimum Vertical Movement Capacities Required for Facing Systems to Cope with Vertical Internal Settlement of Reinforced Fill	115

**Table 1 - Comparison of Various Types of Reinforced Fill Systems**

Type of Reinforced Fill System	Application Areas	Advantages	Limitations/Restrictions
Elemental System (Figure 8)	<ul style="list-style-type: none"> <li>▪ Bridge abutments</li> <li>▪ Retaining walls</li> <li>▪ Construction on slopes</li> <li>▪ Industrial structures</li> <li>▪ Containment dykes</li> <li>▪ Building platforms</li> </ul>	<ul style="list-style-type: none"> <li>▪ Proven technology</li> <li>▪ Can be used with a wide range of reinforcement (generic and proprietary)</li> <li>▪ Provides scope for architectural treatment</li> </ul>	<ul style="list-style-type: none"> <li>▪ Initial cost of shutters for new facing panels system can be high</li> <li>▪ Behaviour of new forms of facing panels needs to be established</li> </ul>
Full Height Facing System (Figure 9)	<ul style="list-style-type: none"> <li>▪ Bridge abutments</li> <li>▪ Retaining walls</li> <li>▪ River training works</li> <li>▪ Industrial structures</li> </ul>	<ul style="list-style-type: none"> <li>▪ Tilt up method provides very rapid construction</li> <li>▪ Full height rigid facing provides very robust structure and inhibits potential failure through the wall face</li> <li>▪ Provides good architectural appearance</li> </ul>	<ul style="list-style-type: none"> <li>▪ Generally limited to use for structures less than 10 m in height only</li> <li>▪ Facing has to be propped during the initial part of the construction</li> <li>▪ Suitable connection detail should be provided to account for differential settlement between facing and fill</li> <li>▪ Suitable fill material and compaction should be provided to mitigate effect of differential settlement</li> </ul>
Wrap-around System (Figure 10)	<ul style="list-style-type: none"> <li>▪ Steep slopes</li> <li>▪ Slope repairs</li> <li>▪ Tall embankments</li> <li>▪ Blast walls</li> <li>▪ Rock fall protection bunds</li> </ul>	<ul style="list-style-type: none"> <li>▪ Use of indigenous fill leads to very economic structures</li> <li>▪ Used to produce “green” structures</li> <li>▪ Can accommodate major distortion without loss of serviceability</li> <li>▪ Composite reinforcement/drainage materials can be used with fine grained fill</li> </ul>	<ul style="list-style-type: none"> <li>▪ Polymeric material used to form the facing are susceptible to vandalism and fire</li> <li>▪ Facing must be protected against ultra violet light</li> </ul>
Segmental Block System (Figure 11)	<ul style="list-style-type: none"> <li>▪ Housing</li> <li>▪ Low to medium height retaining walls</li> <li>▪ Bridge abutments</li> <li>▪ Superimposed structures</li> </ul>	<ul style="list-style-type: none"> <li>▪ Proven technology</li> <li>▪ Rapid construction</li> <li>▪ Requires minimal construction plant</li> <li>▪ Suitable for use with indigenous fill</li> <li>▪ A wide range of segmental block systems permit different architectural treatments</li> </ul>	<ul style="list-style-type: none"> <li>▪ No provision for differential settlement between the fill and the facing</li> <li>▪ Suitable fill material and compaction should be provided to mitigate effect of differential settlement</li> <li>▪ Blockwalls have little adaptability to longitudinal differential settlements</li> </ul>
Anchored Earth System (Figure 12)	<ul style="list-style-type: none"> <li>▪ Suitable for elemental, full height facing and segmental block systems</li> <li>▪ Slope repairs</li> <li>▪ Noise bunds</li> <li>▪ Blast barriers</li> </ul>	<ul style="list-style-type: none"> <li>▪ Anchors produce improved resistance to reinforcement pullout, particularly advantageous at the top of the structures where the fill/reinforcement interaction is critical</li> <li>▪ Anchors formed from used tyres linked by polymeric reinforcing tapes are very economic structures formed using waste materials and indigenous fill</li> </ul>	<ul style="list-style-type: none"> <li>▪ Not used with wrap-around system</li> </ul>

**Table 2 - Sacrificial Thickness to be Allowed on Each Surface of Galvanised Steel Exposed to Corrosion in Selected Fill**

Design Life (years)	Sacrificial Thickness (mm)	
	Non-submerged Structure	Submerged Structure
10	0	0
50	0.30	0.55
60	0.38	0.63
70	0.45	0.70
120	0.75	1.00

- Notes:
- (1) Values based on BS 8006-1 (BSI, 2010). [Amd GG6/01/2017]
  - (2) Galvanised steel shall comply with Section 4.1.5(4).
  - (3) These sacrificial thicknesses apply to steels embedded in selected fill complying with the requirements stated in Clause A.15 of the Model Specification in Appendix A. Sites or fill materials of special aggressiveness should be assessed separately.
  - (4) A sacrificial thickness of 0.5 times the values quoted should be deducted from each internal face of all component parts in close metal-to-metal contact or wholly enclosed within the connection.
  - (5) Submerged structure means structure that is periodically submerged in water but excluding marine conditions and contaminated or saline water.

**Table 3 - Recommended Partial Consequence Factors for the Design of Reinforced Fill Structures and Slopes**

Consequence-to-life	Category 1	Category 2	Category 3
	Economic Consequence		
Category A	1.1	1.1	1.1
Category B	1.1	1.0	1.0
Category C	1.1	1.0	1.0

**Table 4 - Typical Examples of Failures in Each Consequence-to-life Category**

Examples	Consequence-to-life		
	Category 1	Category 2	Category 3
(1) Failures affecting occupied buildings (e.g. residential educational, commercial or industrial buildings, bus shelters <sup>#</sup> , railway platforms).	√		
(2) Failures affecting buildings storing dangerous goods.	√		
(3) Failures affecting heavily used open spaces and recreational facilities (e.g. sitting-out areas, playgrounds, car parks).		√	
(4) Failures affecting roads with high vehicular or pedestrian traffic density.		√	
(5) Failures affecting public waiting areas (e.g. bus stops <sup>#</sup> , petrol stations).		√	
(6) Failures affecting country parks and lightly used open-air recreation areas.			√
(7) Failures affecting roads with low traffic density.			√
(8) Failures affecting storage compounds (non-dangerous goods).			√

**Legend:**

# In the context of this Table, bus shelters are those with a cover that shelters people waiting there from direct sunlight or rainfall, while bus stops are those without such a cover.

Note: Table based on Works Bureau Technical Circular No. 13/99 and Geotechnical Manual for Slopes (GEO, 1984).



**Table 5 - Typical Examples of Failures in Each Economic Consequence Category**

Examples	Economic Consequence		
	Category A	Category B	Category C
(1) Failures affecting buildings, which could cause excessive structural damage.	√		
(3) Failures affecting essential services <sup>#</sup> which could cause loss of that service for an extended period.	√		
(3) Failures affecting rural or urban trunk roads or roads of strategic importance.	√		
(4) Failures affecting essential services <sup>#</sup> which could cause loss of that service for a short period.		√	
(5) Failures affecting rural (A) or primary distributor roads which are not sole accesses.		√	
(6) Failures affecting open-air car parks.			√
(7) Failures affecting rural (B), feeder, district distributor and local distributor roads which are not sole accesses.			√
(8) Failures affecting country parks.			√

**Legend:**

# Essential services are those that serve a district and are with no or very inferior alternatives. Examples are mass transit facilities and trunk utility services.

Note: Table based on Works Bureau Technical Circular No. 13/99 and Geotechnical Manual for Slopes (GEO, 1984).

**Table 6 - Recommended Partial Material Factors for the Design of Reinforced Fill Structures and Slopes**

Material Parameter	Partial Material Factor, $\gamma_m$	
	Ultimate Limit State	Serviceability Limit State
Fill: unit weight, $\gamma$	1.0	1.0
effective shear strength, $\tan \phi'$	1.2	1.0
Ground: effective shear strength <sup>(2)</sup>	1.2	1.0
base friction, $\tan \delta_b$	1.2	1.0
Granular fill and drainage materials:		
Permeability, k	10.0	-
Structural elements:		
Reinforcement tensile strength	1.5 <sup>(3)</sup>	-
facing strength	as per relevant structural code	-
Fill-to-reinforcement interaction:		
sliding resistance	1.2 <sup>(4)</sup>	-
pullout resistance	1.2 <sup>(4)</sup>	-
Facing units interaction:		
unit-to-unit resistance	1.2	-
unit-to-reinforcement resistance	1.2	-

- Notes :
- (1) Fill refers to the fill, both reinforced and unreinforced, placed and compacted according to the specification for the construction of a reinforced fill structure or slope.
  - (2) For a  $c' - \phi'$  (Mohr-Coulomb) strength model, the value of  $\gamma_m$  should be applied to the selected values of shear strength parameters  $c' - \tan \phi'$ .
  - (3) For steel reinforcement,  $\gamma_m$  can be taken as 1.5. Values of  $\gamma_m$  for proprietary polymeric reinforcement are specified in the relevant reinforced fill product design data sheet issued by the Civil Engineering and Development Department of the Hong Kong SAR Government. [Amd GG6/01/2022]
  - (4) For steel reinforcement,  $\gamma_m$  can be taken as 1.2. Values of  $\gamma_m$  for proprietary polymeric reinforcement are specified in the relevant reinforced fill product design data sheet issued by the Civil Engineering and Development Department of the Hong Kong SAR Government. [Amd GG6/01/2022]

**Table 7 - Recommended Partial Load Factors for the Design of Reinforced Fill Structures and Slopes**

Loading	Partial Load Factor, $\gamma_f$	
	Ultimate Limit State	Serviceability Limit State
Dead load due to weight of the reinforced fill	1.0	1.0
Dead load due to weight of the facing	1.0	1.0
External dead load (e.g. line or point loads)	1.5	1.0
External live load (e.g. traffic loading)	1.5	1.0
Seismic load	1.0	1.0
Water pressure	1.0	1.0

- Notes :
- (1)  $\gamma_f$  should be set to zero for those external or surcharge loads which produce a favourable effect.
  - (2) The external loads to which the partial load factors are associated should be the characteristic values in their original unfactored state.
  - (3) The worst credible water pressure loading should be considered when designing reinforced fill structures and slopes.

**Table 8 - Recommended Partial Load Factors for Load Combinations for Reinforced Fill Retaining Walls and Bridge Abutments**

Loading	Load Combination Partial Load Factors $\gamma_f$		
	A <sup>(1)</sup>	B <sup>(2)</sup>	C <sup>(3)</sup>
Dead load due to weight of reinforced fill	1.0	1.0	1.0
Dead load due to weight of facing	1.0	1.0	1.0
External dead load on top of structure	1.5	1.0	1.0
External earth loading generated behind the structure	1.0	1.0	1.0
External live loads:			
(i) on reinforced fill block	1.5	0	0
(ii) behind reinforced fill block	1.5	1.5	0
Temperature effects on external loads (e.g. thermal expansion)	1.5	1.5	–

- Notes :
- (1) Load combination A: considers the maximum values of all loads and normally generates the maximum reinforcement tension and foundation bearing pressure.
  - (2) Load combination B: considers the maximum overturning loads from the retained ground together with the minimum self weight of the structure and superimposed traffic load. This combination usually dictates the reinforcement requirement for pullout resistance and is usually the worst case for sliding along the base.
  - (3) Load combination C: considers dead load only with unit partial load factors. This combination is used to determine foundation settlements and reinforcement tension for checking the serviceability limit state.

**Table 9 - Tolerance of Reinforced Fill Facing Systems to Differential Settlement**

Maximum Differential Settlement	Comment
1 in 1000	Not normally significantly
1 in 200	Full-height panels may be affected by joints closing or opening
1 in 100	Normal safe limit for discrete concrete panel facings without special precautions
1 in 50	Normal safe limit for semi-elliptical steel facings or geosynthetic facings
1 in < 50	Distortion may affect retaining ability of soft facings

Notes : (1) Table based on BS 8006-1 (BSI, 2010). [Amd GG6/01/2017]  
(2) Details of tolerance of reinforced fill to differential settlement can be found in TRRL Report 123 (Jones, 1989).

**Table 10 - Minimum Vertical Movement Capacities Required for Facing Systems to Cope with Vertical Internal Settlement of Reinforced Fill**

Structural Form	Minimum Vertical Movement Capacity of System
Discrete panels	Joint closure of 1 in 150 relative to panel height
Full-height panels	Vertical movement capacity of connections 1 in 150 relative to panel height
Semi-elliptical steel facings	Vertical distortion of 1 in 150 relative to panel height
Geosynthetic wraparound facings	No specific limit except for appearance or serviceability consideration

Note : Values based on BS 8006-1 (BSI, 2010). [Amd GG6/01/2017]

Figures

**List of Figures**

Figure No.		Page No.
1	Locations and Statistics of Reinforced Fill Features in Hong Kong	121
2	The Use of Reinforced Fill in Highway and Railway Application	122
3	The Use of Reinforced Fill in Housing Development	123
4	The Use of Reinforced Fill in Slope Stabilization and Landslide Mitigation	124
5	Other Common Usage	125
6	Examples of Economic and Technical Advantages of Reinforced Fill	126
7	Ecological Parameters for a 6 m High Reinforced Fill Structure and an Equivalent Reinforced Concrete Structure	127
8	Elemental System	128
9	Full Height System	129
10	Wrap-around System	130
11	Segmental Block System	131
12	Anchored Earth System	132
13	Classification of Common Earth Retention Systems	133
14	Forms of Reinforcement and Mechanism of Reinforced Fill	134
15	Effects of Reinforcement on Equilibrium and Action in Direct Shear	135
16	Condition of Strain Compatibility	136
17	Potential Slip Planes in Walls and Slopes	137

Figure No.		Page No.
18	Influence of Foundation Condition on Reinforced Fill Structures	138
19	Interactions between Fill and Reinforcement	139
20	Pullout Resistance of Grid Reinforcement	140
21	Pullout Resistance of Anchor Reinforcement	141
22	Effect of Friction Angle and Particle Size on Pullout Resistance	142
23	Polymeric Reinforcement	143
24	Typical Tensile Strength and Extension Characteristics of Polymeric Reinforcement	144
25	Typical Creep Curves of Different Polymeric Reinforcement	145
26	Connections in Geotextiles and Polymeric Reinforcement	146
27	Design Considerations for Reinforced Fill Structures and Slopes	147
28	Ultimate Limit States – External Instability	148
29	Ultimate Limit States – Internal Instability	149
30	Ultimate Limit States – Compound Instability	150
31	Serviceability Limit States	151
32	Construction Sequence of Earth Retaining Structures	152
33	Design Procedure for Reinforced Fill Structures	153
34	Initial Sizing and Embedment	154
35	Stresses Imposed due to Self Weight, Surcharge and Retained Backfill	155
36	Design Methods for Internal Stability Analysis of Reinforced Fill Structures	156

Figure No.		Page No.
37	Tensile Force due to Vertical Load $P_L$ on Top of the Structure	157
38	Tensile Force due to Horizontal Load $F_P$ on Top of the Structure	158
39	Internal Wedge Stability Analysis	159
40	Compound Wedge Stability Analysis using Two-part Wedge Method	160
41	Geometry and Maximum Tension Lines for Bridge Abutments and Piled Bank Seat	161
42	Compound Stability Analysis	162
43	Typical Drainage Layouts for Reinforced Fill Structures and Slopes	163
44	Typical Drainage Layouts for Highway and River Training Application	164
45	Definition and Location of Maximum Tension Lines of Superimposed Walls	165
46	Additional Vertical Stress on Reinforcement for Superimposed Wall	166
47	Geometry and Earth Pressure Distribution of Segmental Block Wall	167
48	Hinge Height for Segmental Block Wall Design	168
49	Analysis of Block Sliding Failure of Segmental Block Wall	169
50	Walls with a Stepped Base	170
51	Back-to-Back Walls	171
52	Typical Corner Details of Reinforced Fill Structures	172
53	Typical Joint Details of Reinforced Fill Structures	173
54	Design Procedure for Reinforced Fill Slopes	174



Figure No.		Page No.
55	Pullout of Reinforcement from the Reinforced Block	175
56	Determination of Overall Slope Stability	176
57	Simplified Method of the Evaluation of Compaction-induced Stress	177
58	Determination of the Design Tension in Reinforcement by Rigorous Method of Limit Equilibrium Analysis	178
59	Estimation of the Design Tension by Two-part Wedge Method	179

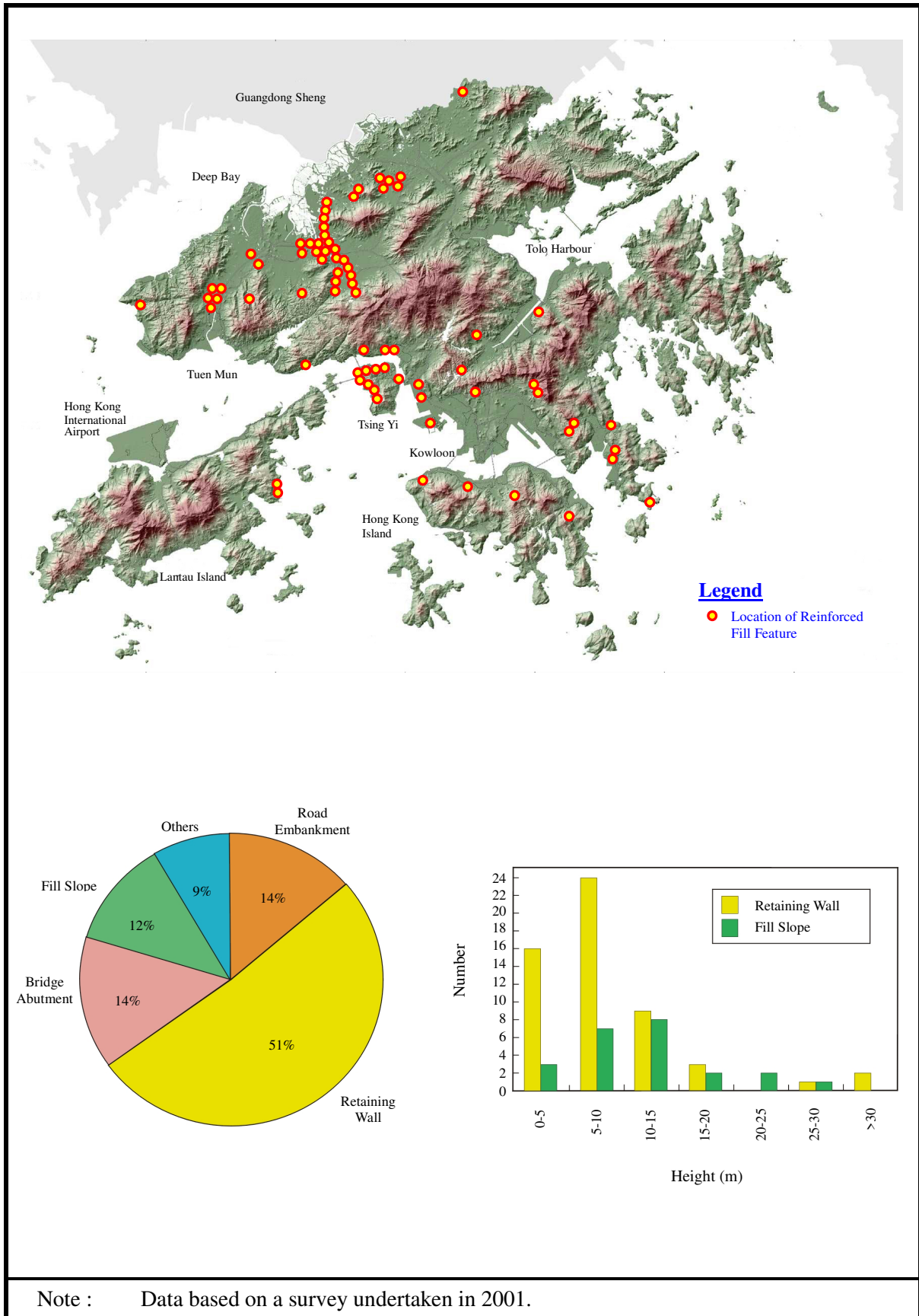


Figure 1 – Locations and Statistics of Reinforced Fill Features in Hong Kong

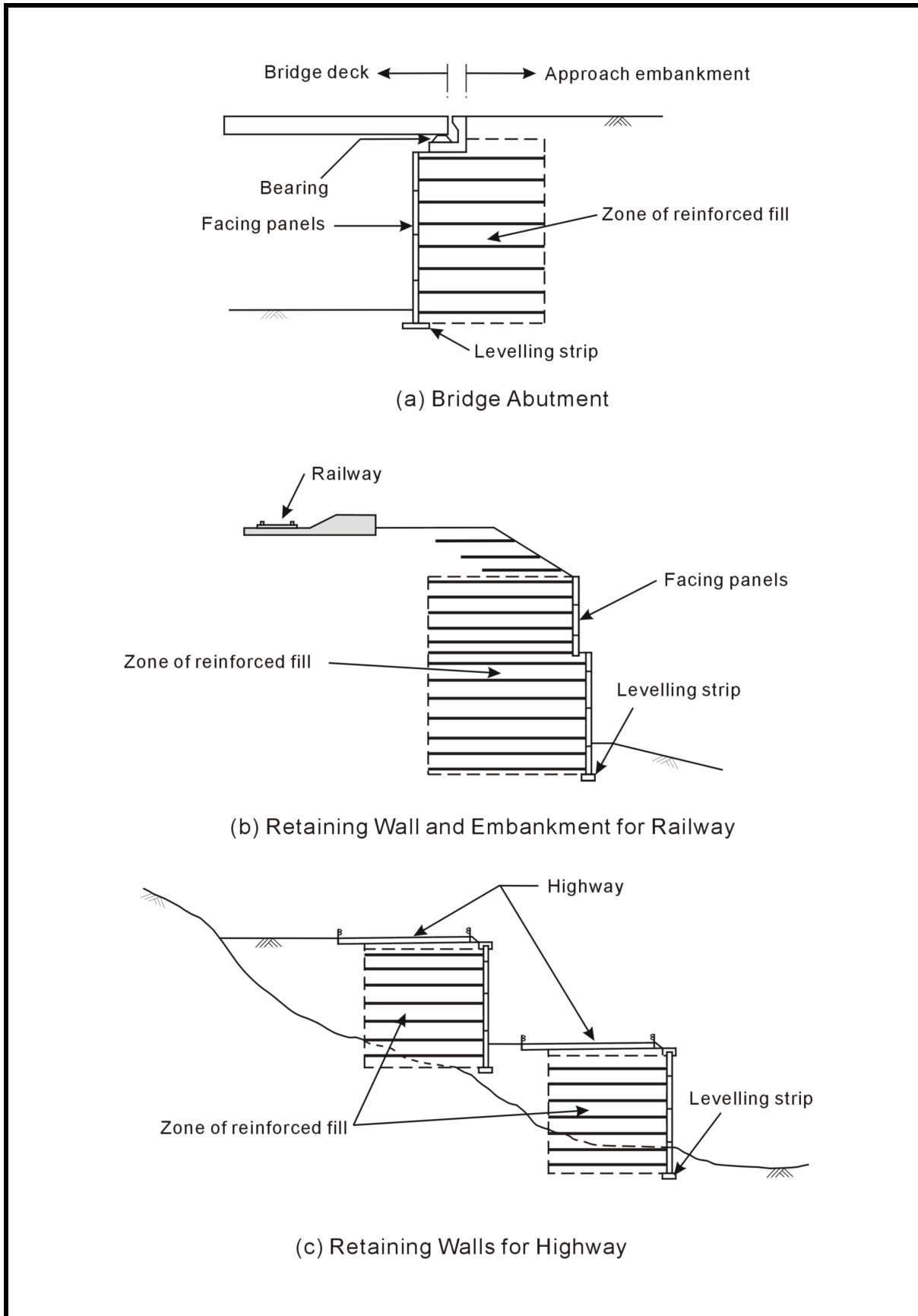
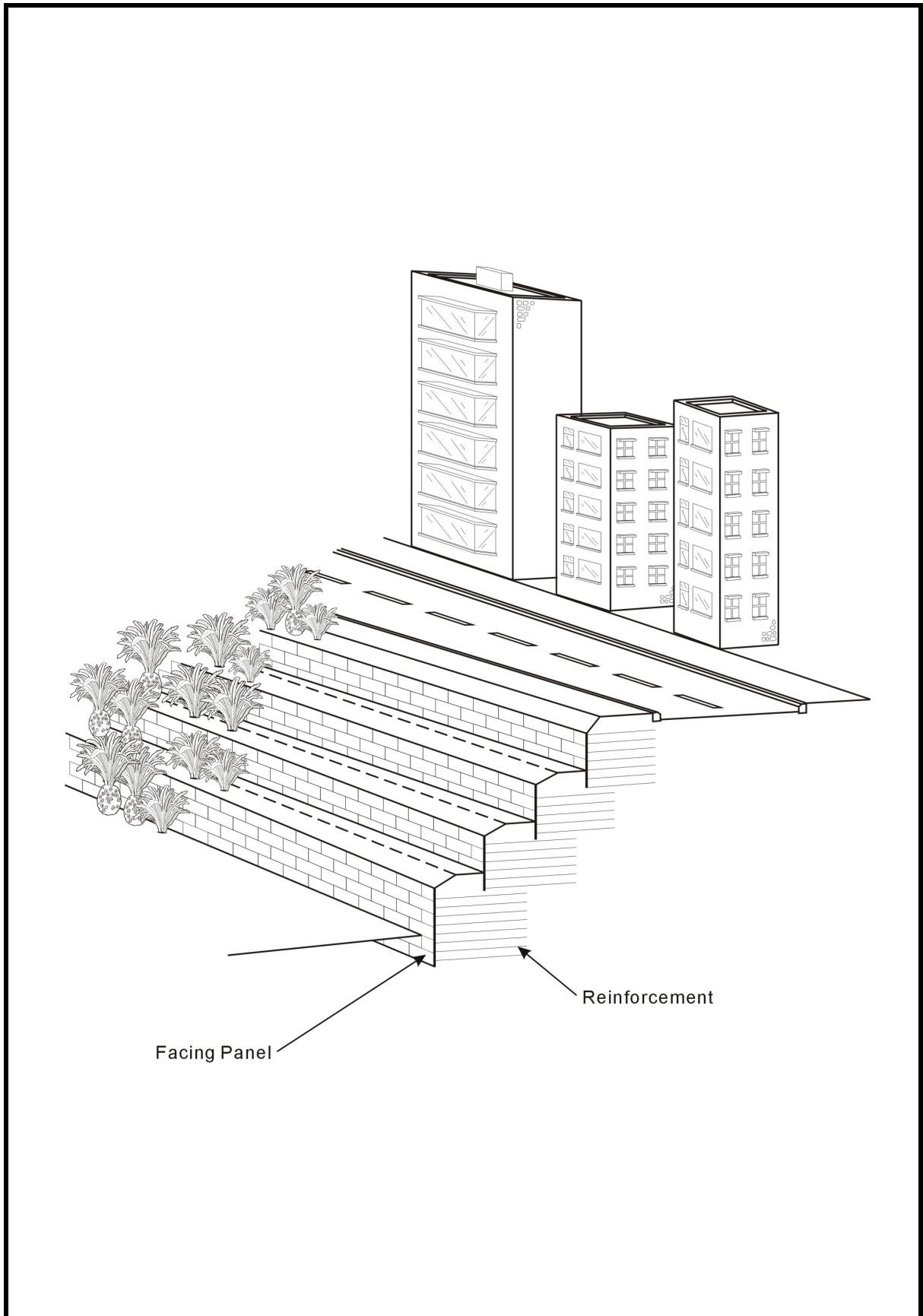
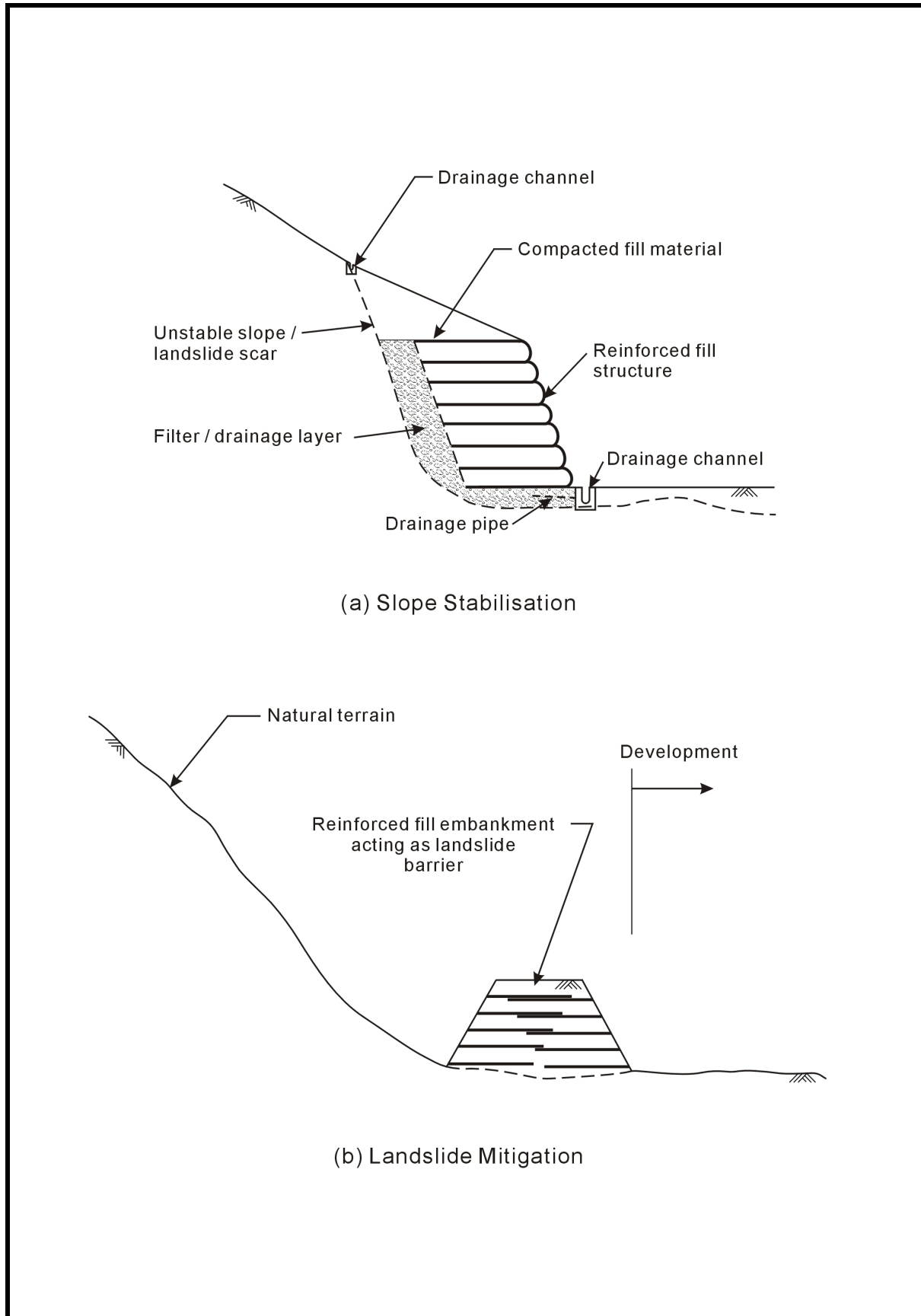


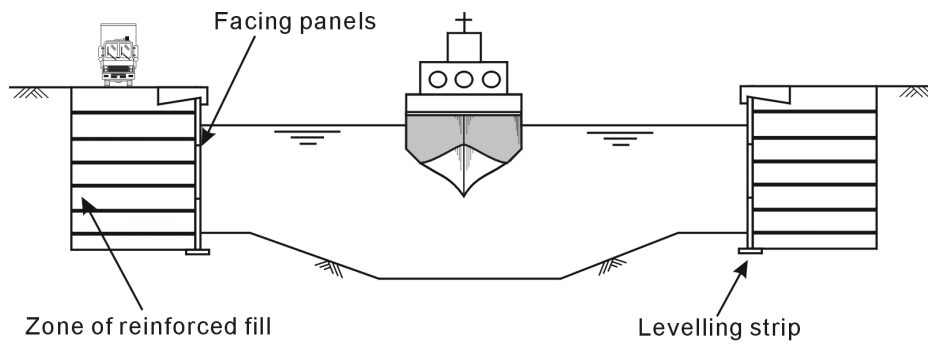
Figure 2 – The Use of Reinforced Fill in Highway and Railway Application



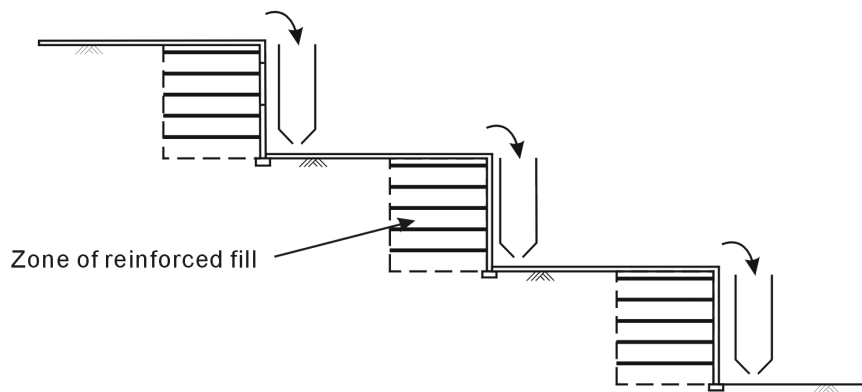
**Figure 3 – The Use of Reinforced Fill in Housing Development**



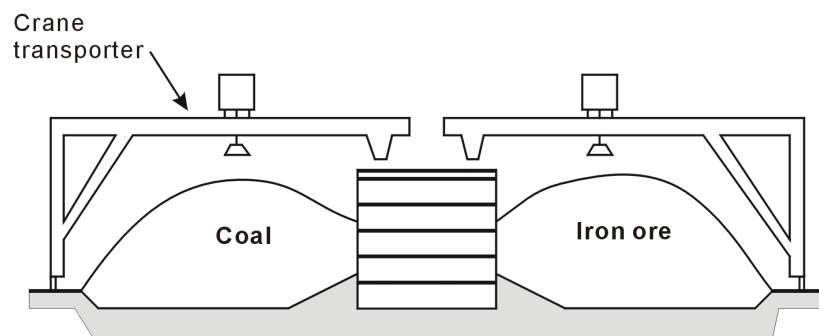
**Figure 4 – The Use of Reinforced Fill in Slope Stabilization and Landslide Mitigation**



(a) River Training Structures

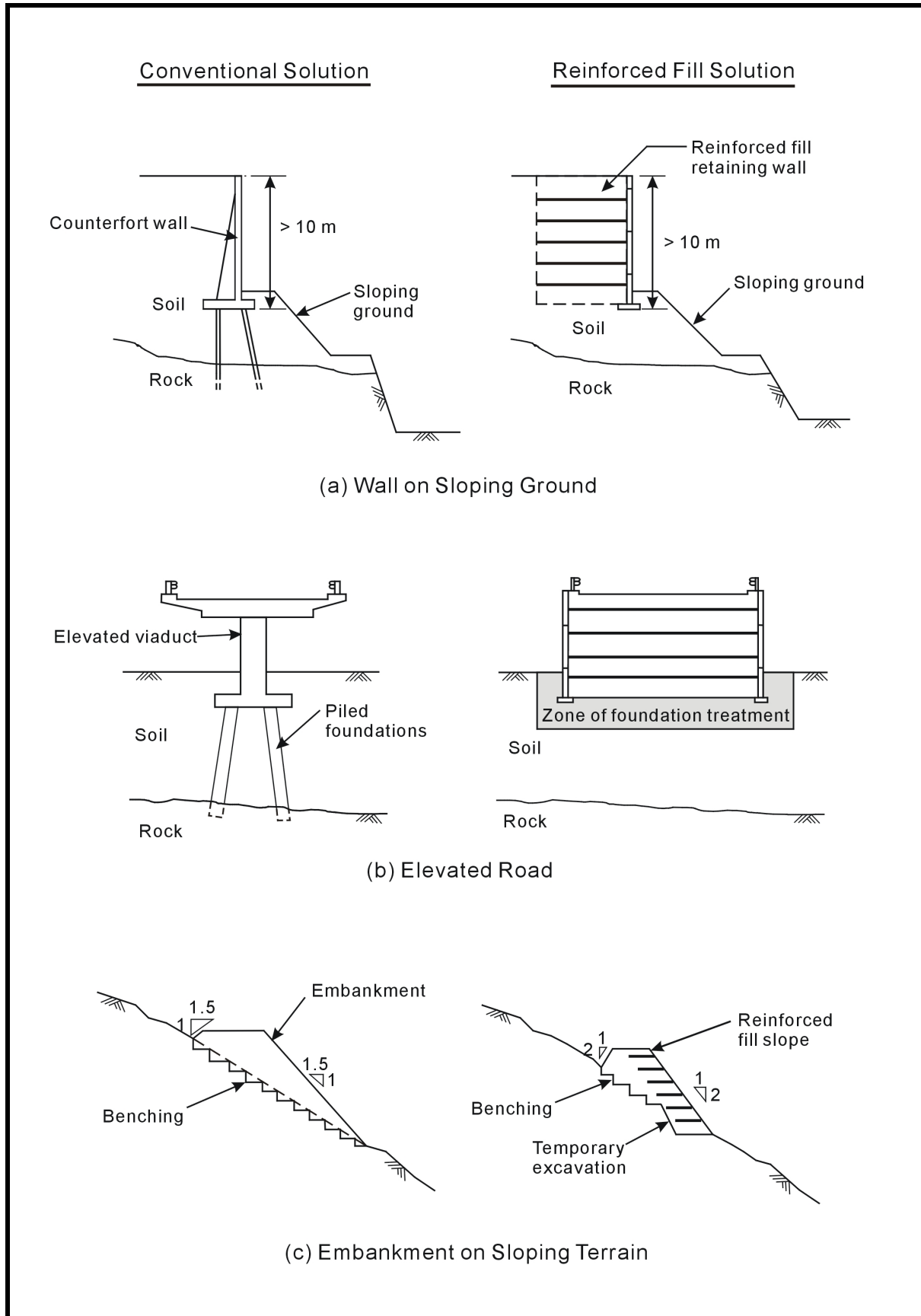


(b) Rock Crushing Plant

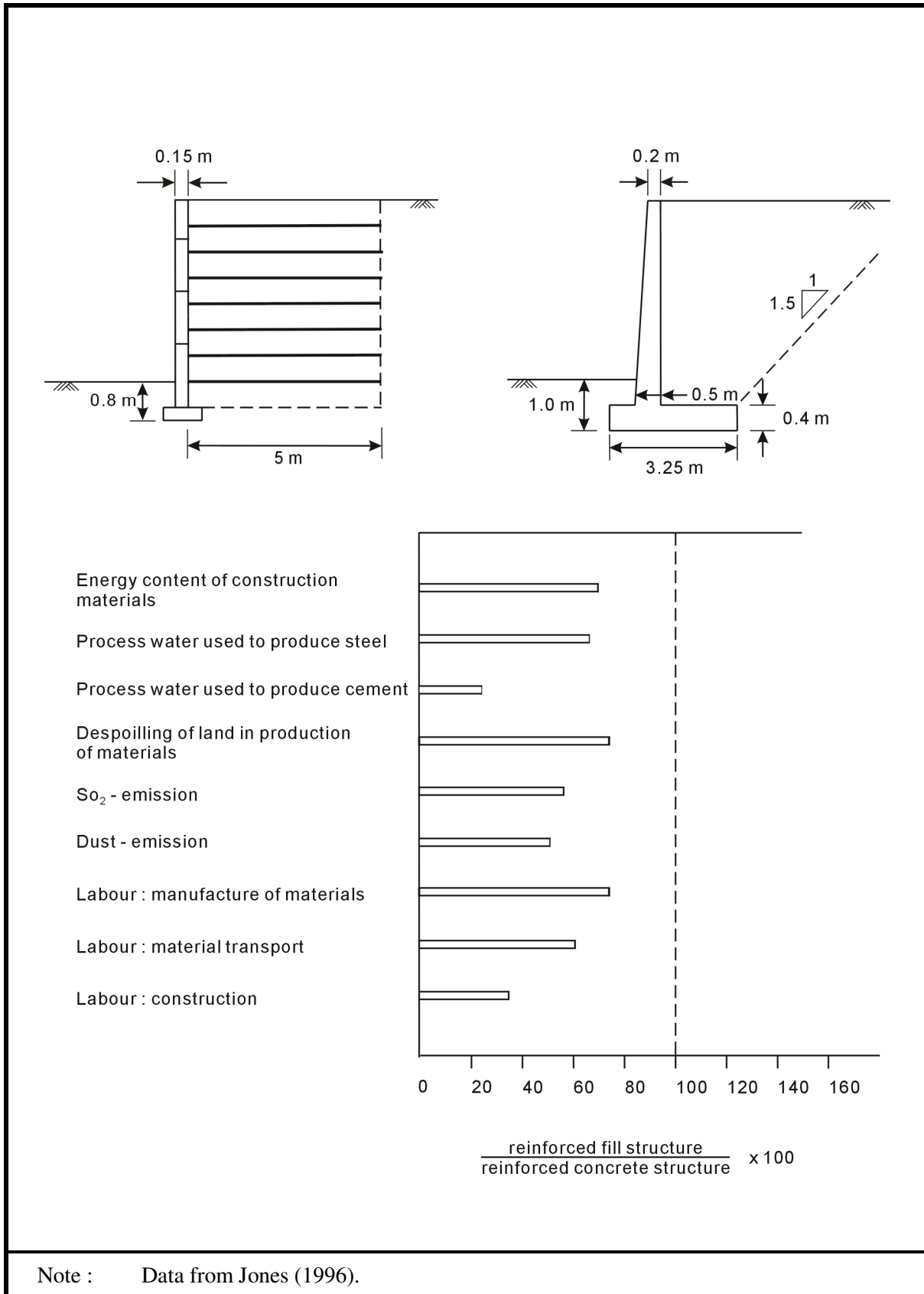


(c) Material Storage Facility

**Figure 5 – Other Common Usage**

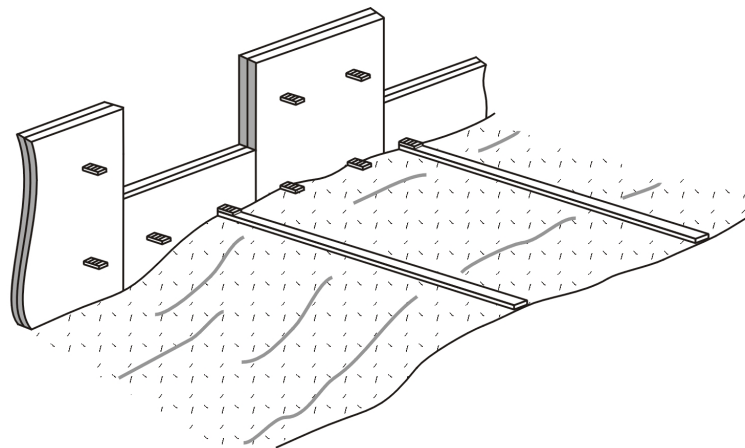


**Figure 6 – Examples of Economic and Technical Advantages of Reinforced Fill**

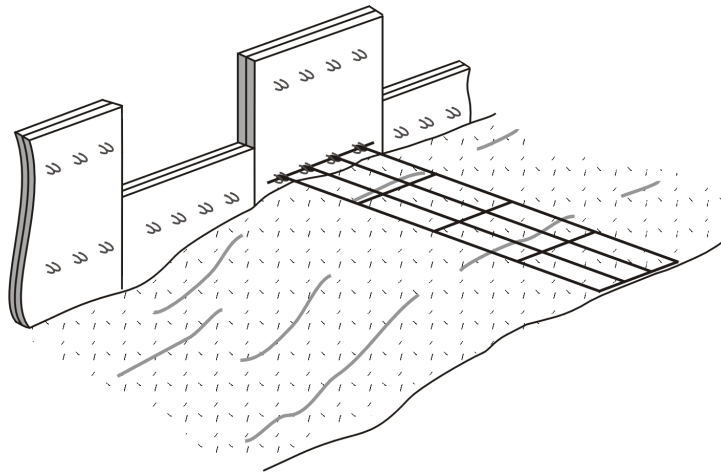


**Figure 7 – Ecological Parameters for a 6 m High Reinforced Fill Structure and an Equivalent Reinforced Concrete Structure**

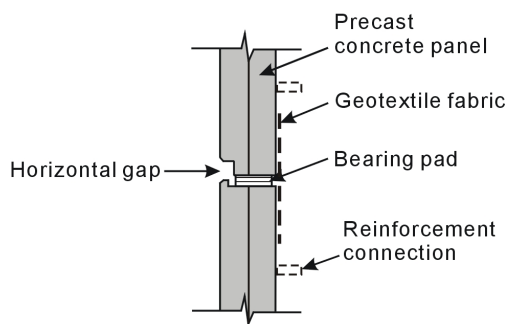




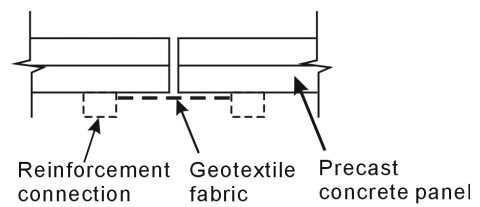
(a) Schematic View of Elemental Facing with Strip Reinforcement



(b) Schematic View of Elemental Facing with Grid Reinforcement

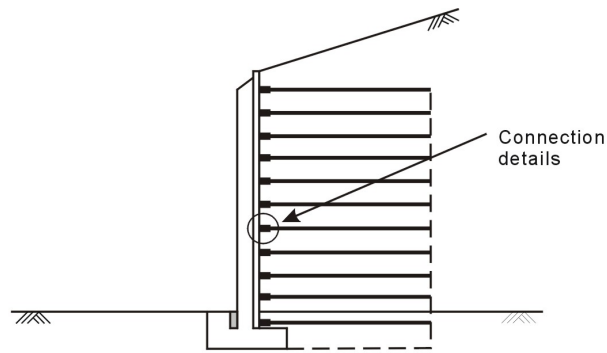


(c) Typical Horizontal Joint between Facing Panel (Side Elevation)

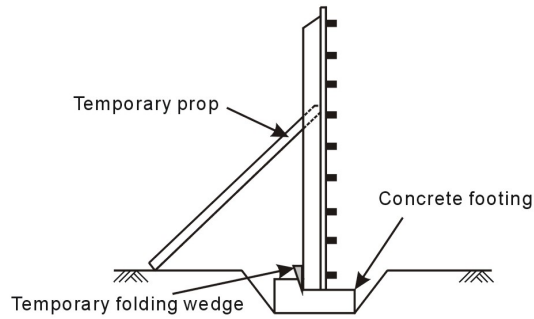


(d) Typical Vertical Joint between Facing Panel (Plan)

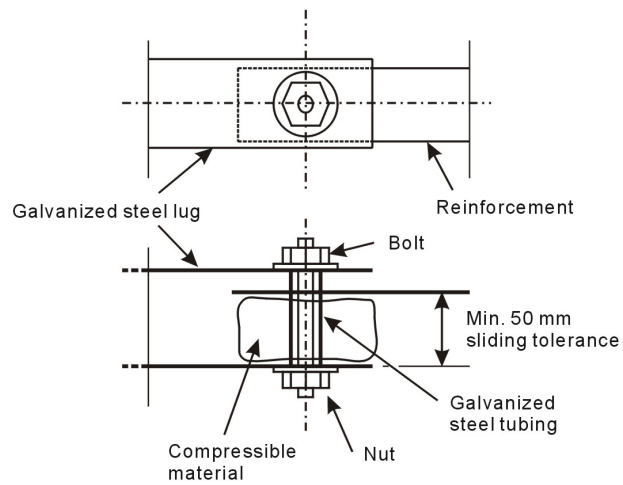
**Figure 8 – Elemental System**



(a) Wall with Full Height Facing



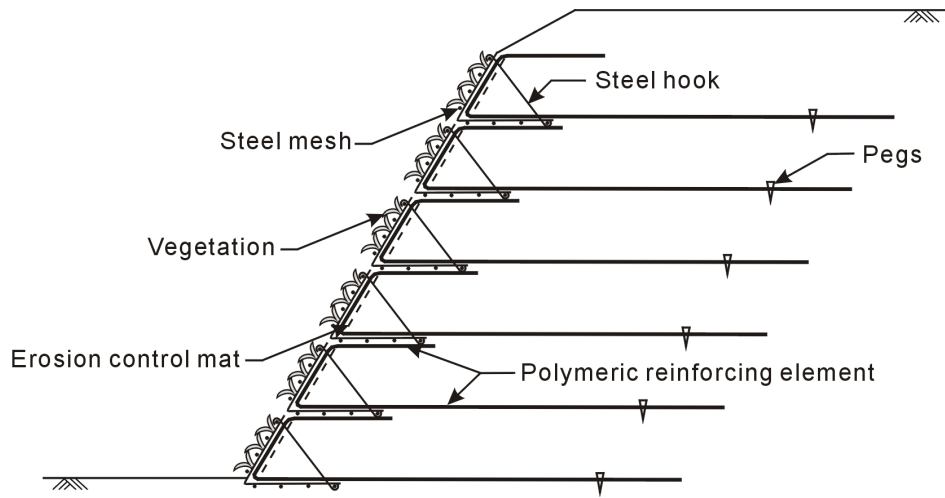
(b) Erection of Prop



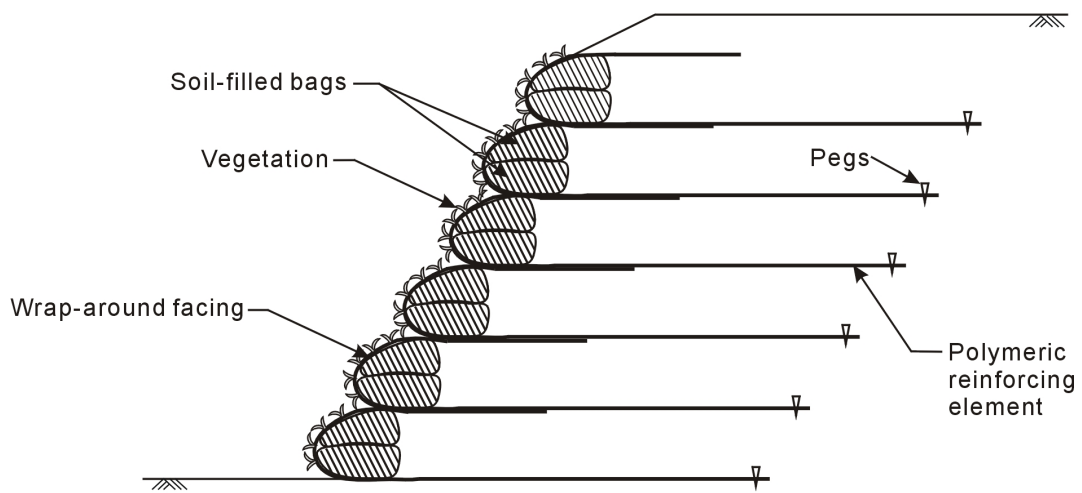
(c) Connection Details

Note : Figure based on Jones (1996).

**Figure 9 – Full Height System**



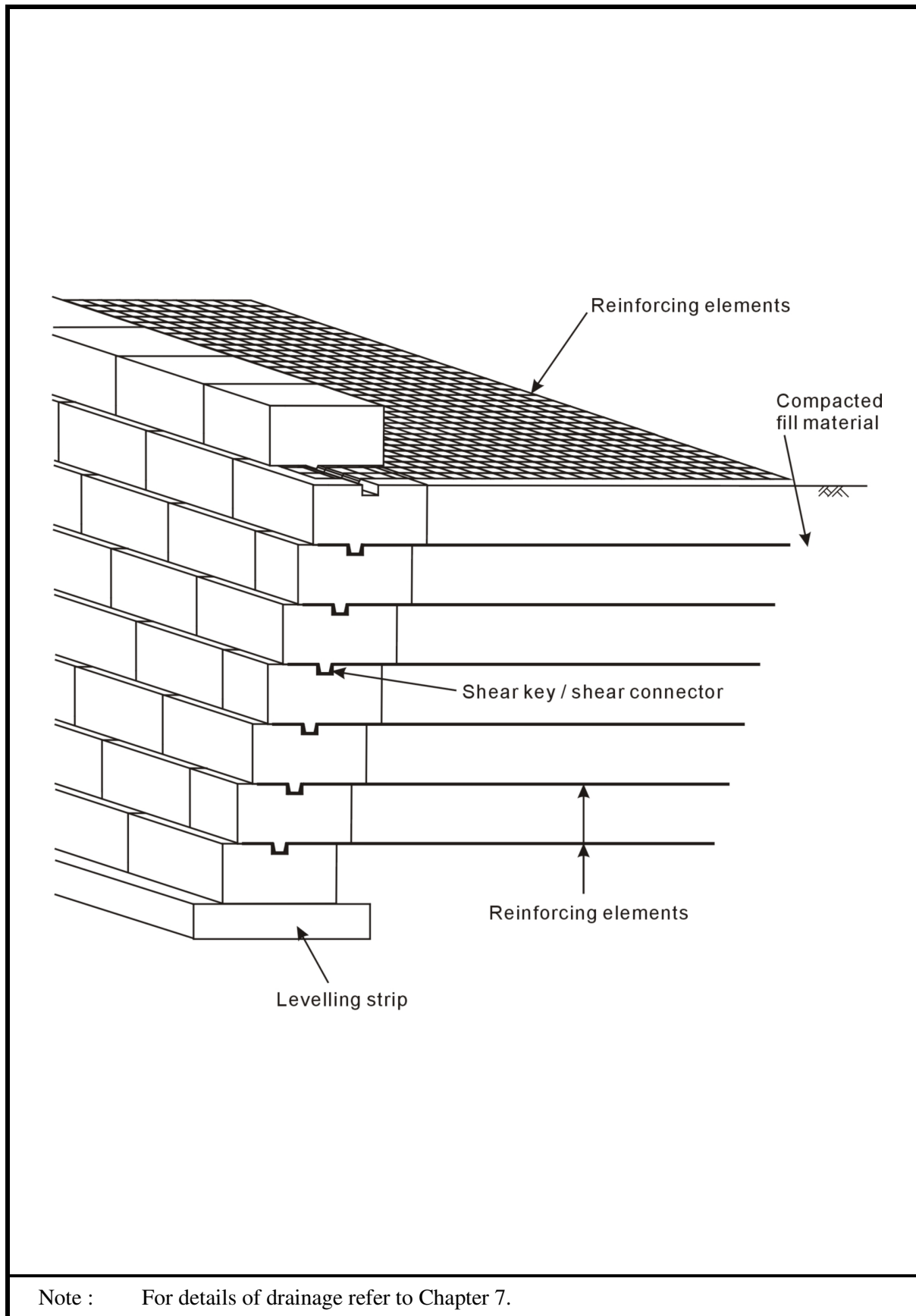
(a) Wrap-around Facing with Steel Meshes

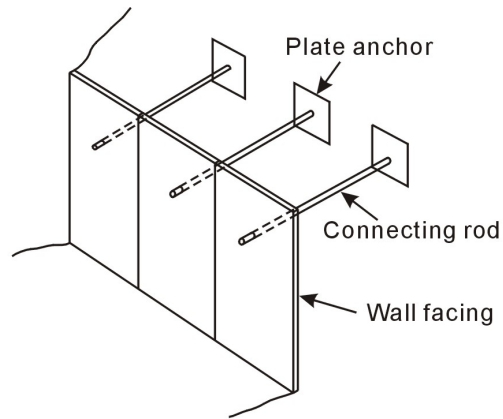


(b) Wrap-around Facing with Soil Filled Bags

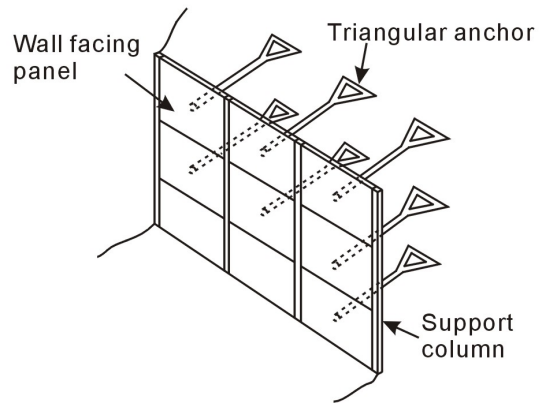
Note : For details of drainage refer to Chapter 7.

**Figure 10 – Wrap-around System**

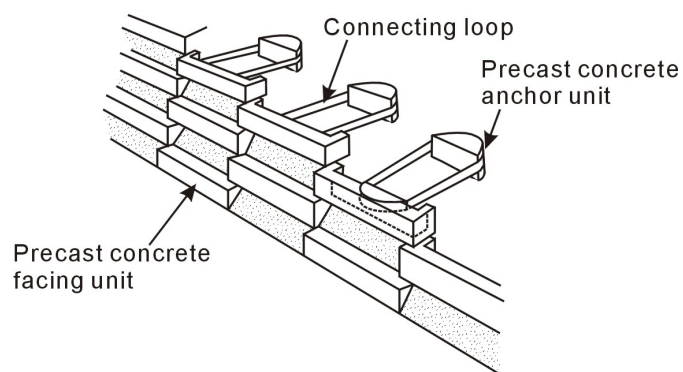
**Figure 11 – Segmental Block System**



(a) Use of Plate Anchors



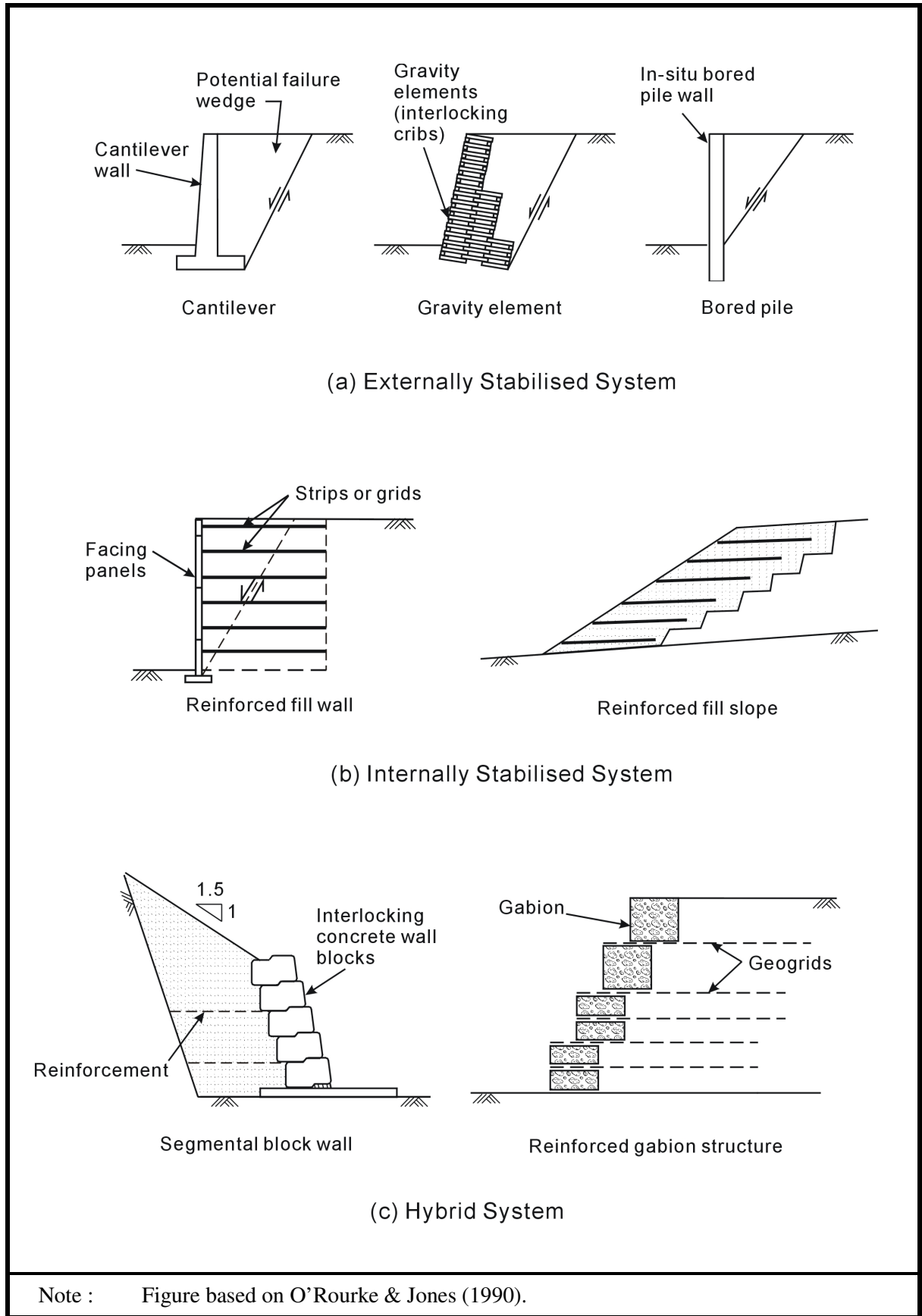
(b) Use of Hollow Triangular Anchors



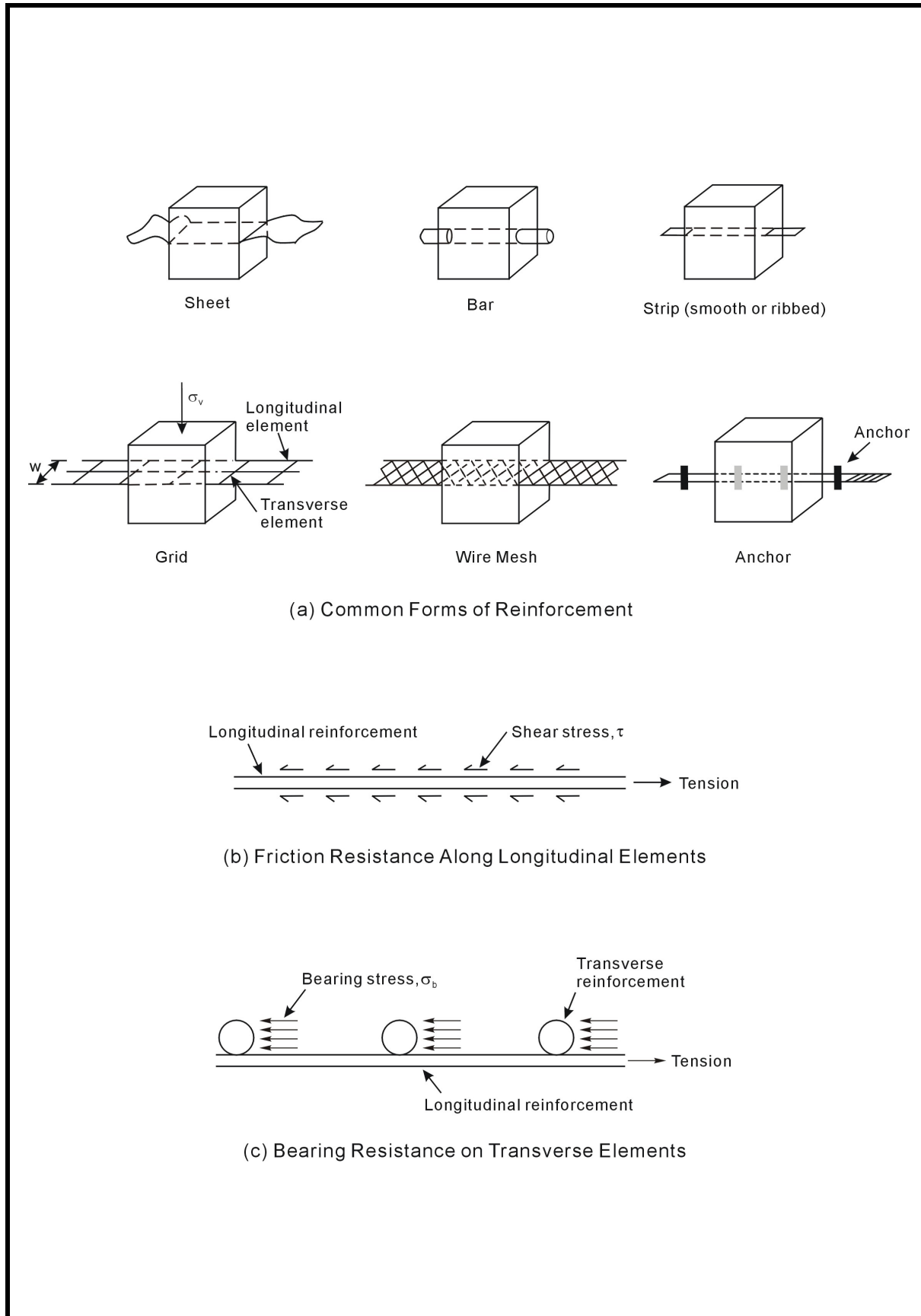
(c) Use of Loop Anchors

Note : Figures based on Jones (1996).

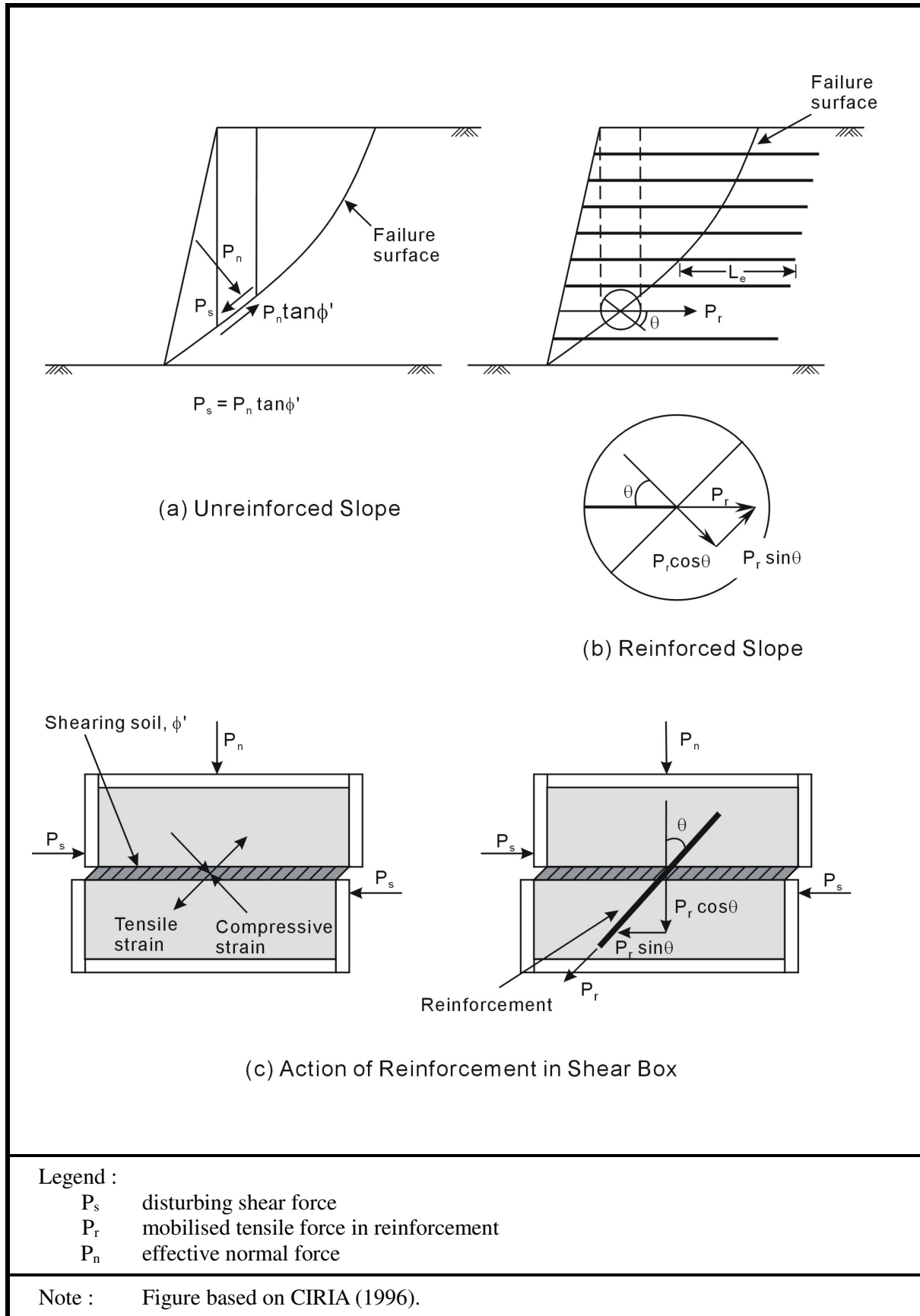
**Figure 12 – Anchored Earth System**



**Figure 13 – Classification of Common Earth Retention Systems**

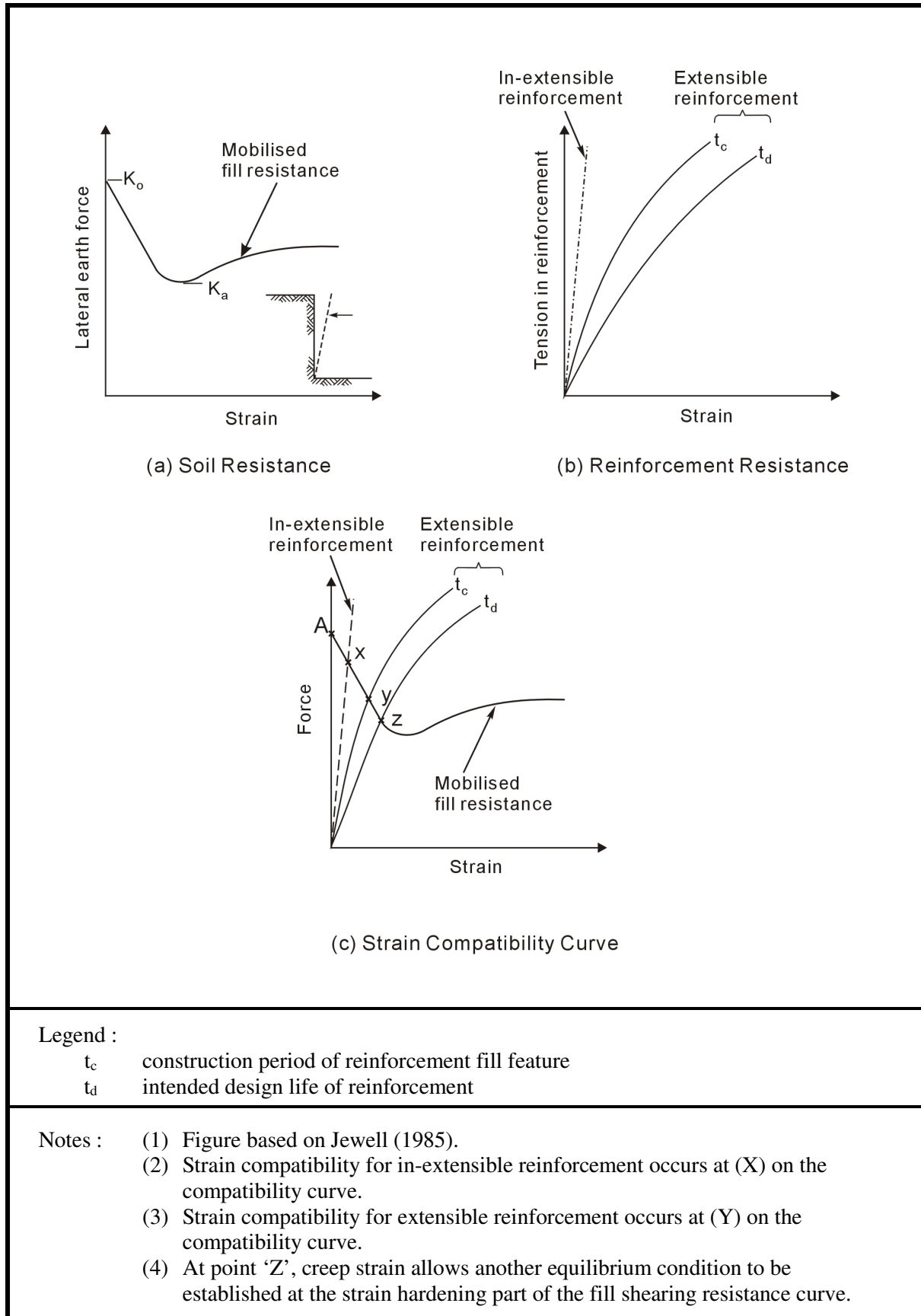


**Figure 14 – Forms of Reinforcement and Mechanism of Reinforced Fill**

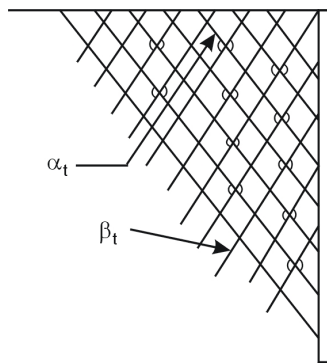


**Figure 15 – Effects of Reinforcement on Equilibrium and Action in Direct Shear**

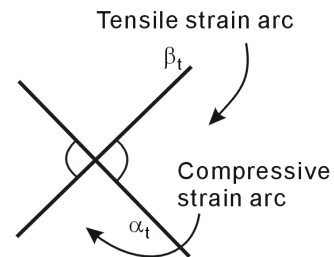




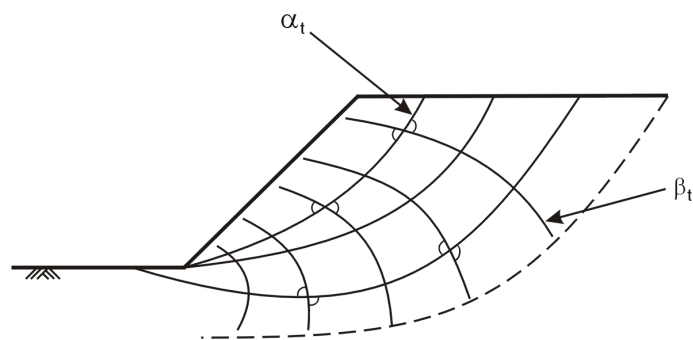
**Figure 16 – Condition of Strain Compatibility**



(a) Strain Field for Wall



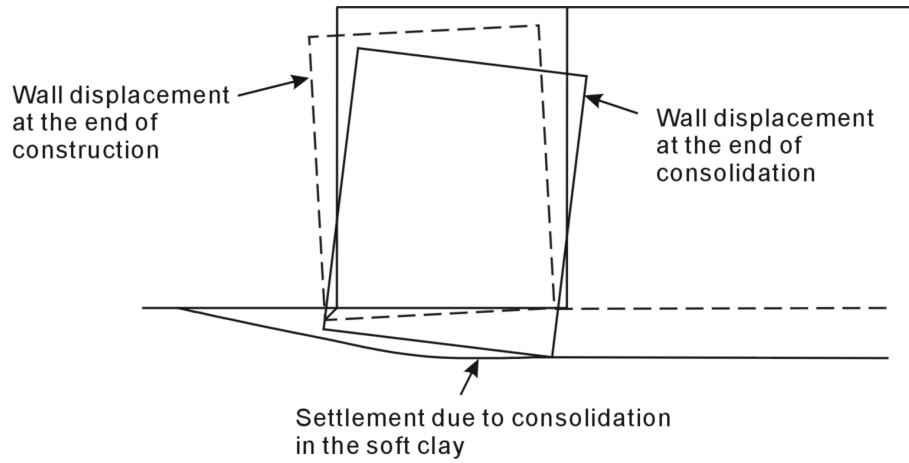
(b) Location of Compressive And Tensile Strain Arcs



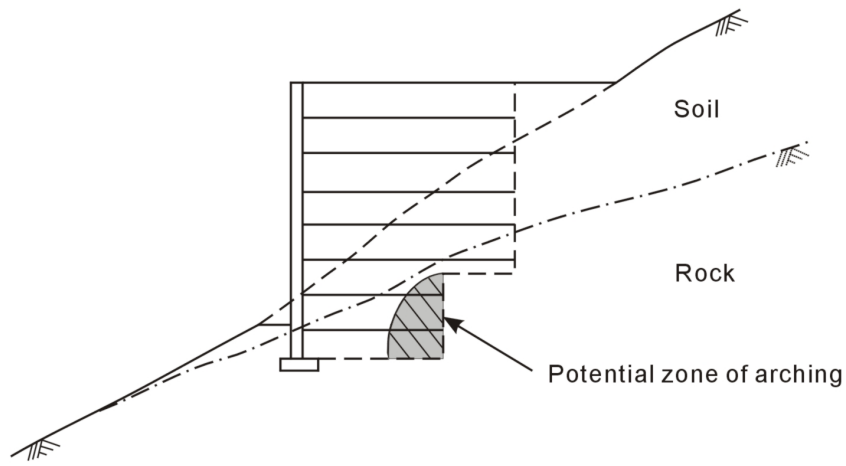
(c) Strain Field Through and Beneath an Embankment

- Notes :
- (1) Figure based on Milligan (1974), Jones (1996), Bassett & Last (1978).
  - (2) Reinforcement orientated in a plane within the tensile strain arc will act in tension.
  - (3) Reinforcement orientated in a plane within the compressive strain arc will act in compression.
  - (4) Reinforcement orientated along an  $\alpha$  trajectory will lubricate the failure plane.

**Figure 17 – Potential Slip Planes in Walls and Slopes**



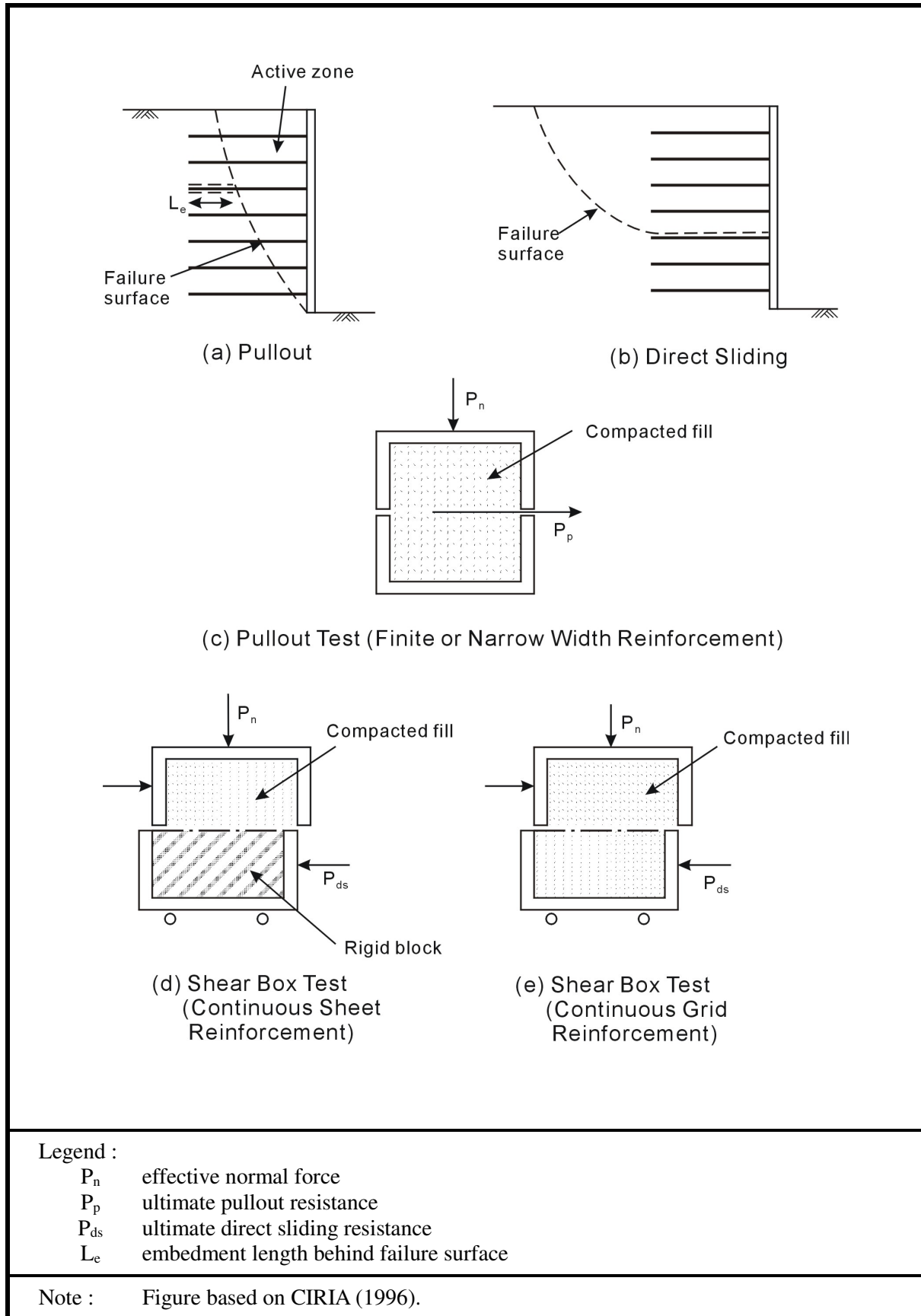
(a) Wall Displacement on a Weak Foundation



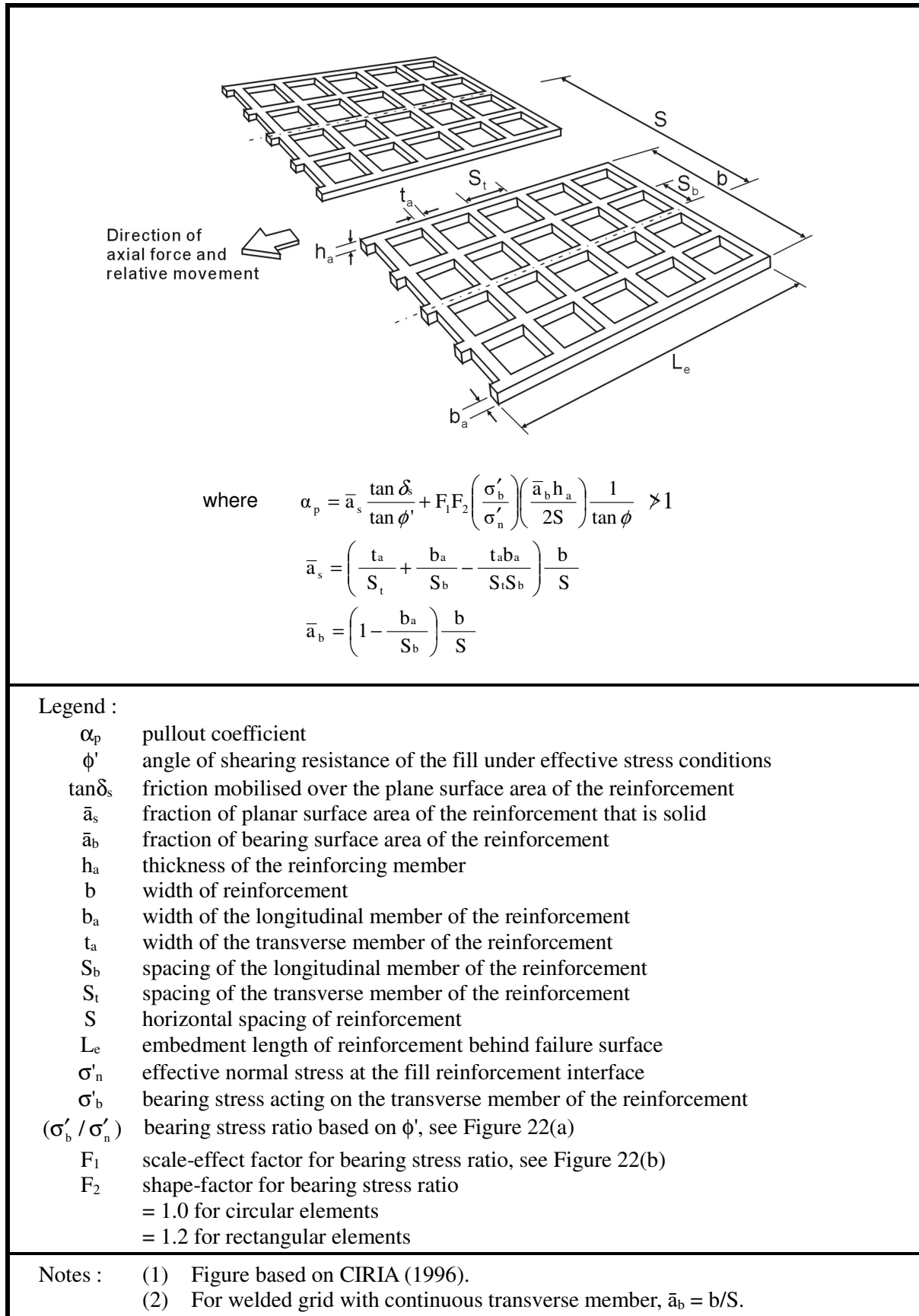
(b) Potential for Arching on Stepped Foundation

Note : Figure based on Jones (1996) and Nicu et al (1970).

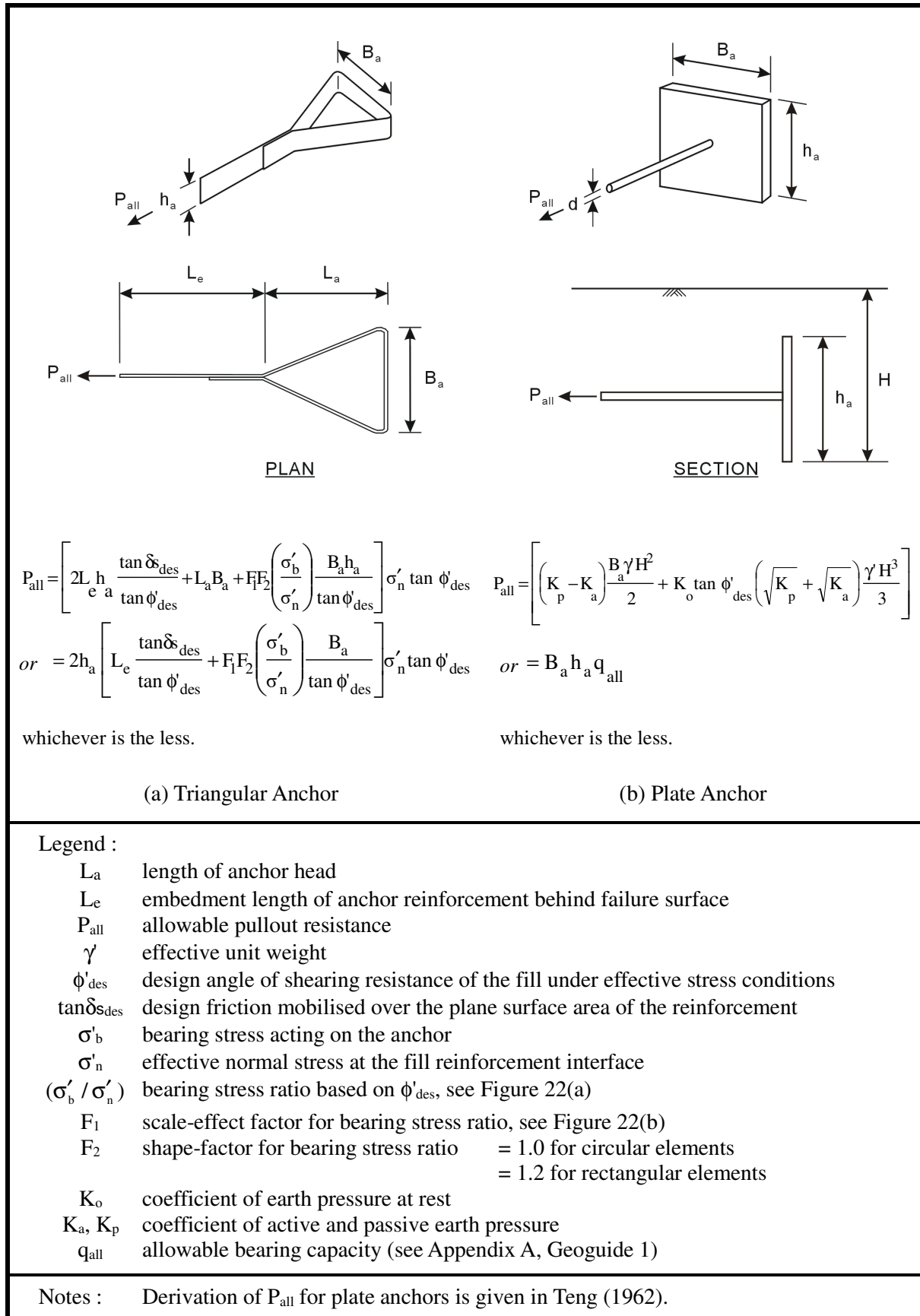
**Figure 18 – Influence of Foundation Condition on Reinforced Fill Structures**



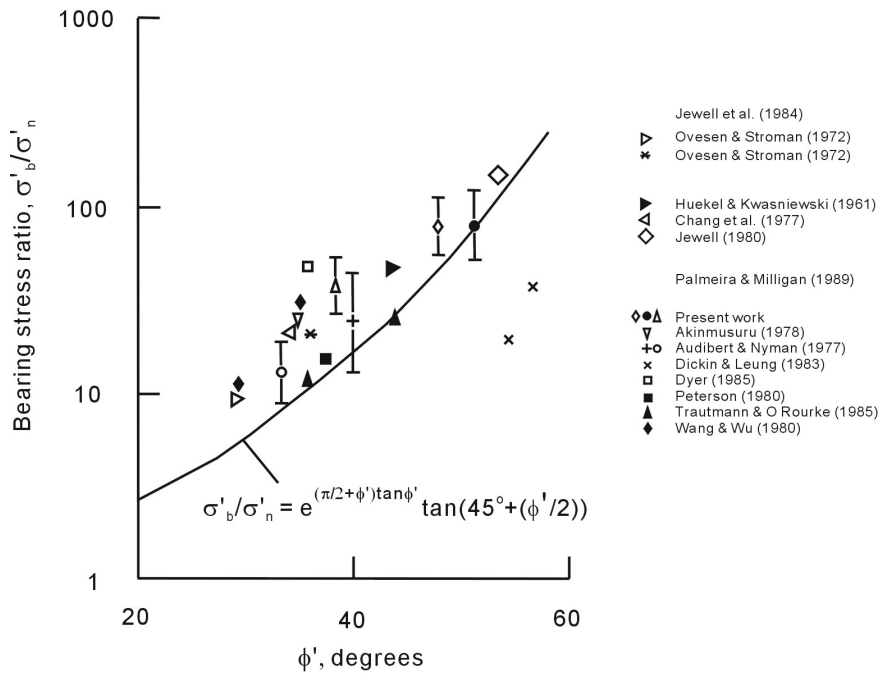
**Figure 19 – Interactions between Fill and Reinforcement**



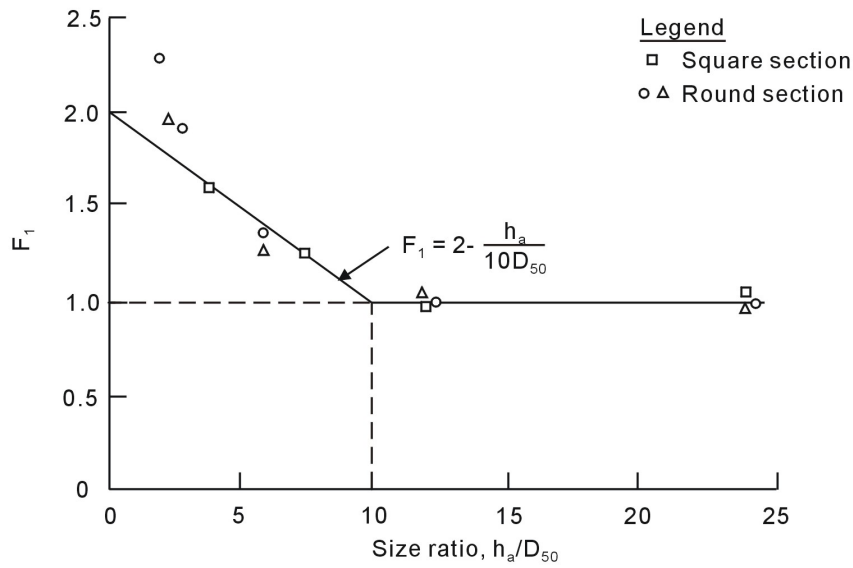
**Figure 20 – Pullout Resistance of Grid Reinforcement**



**Figure 21 – Pullout Resistance of Anchor Reinforcement**



(a) Bearing stress ratio



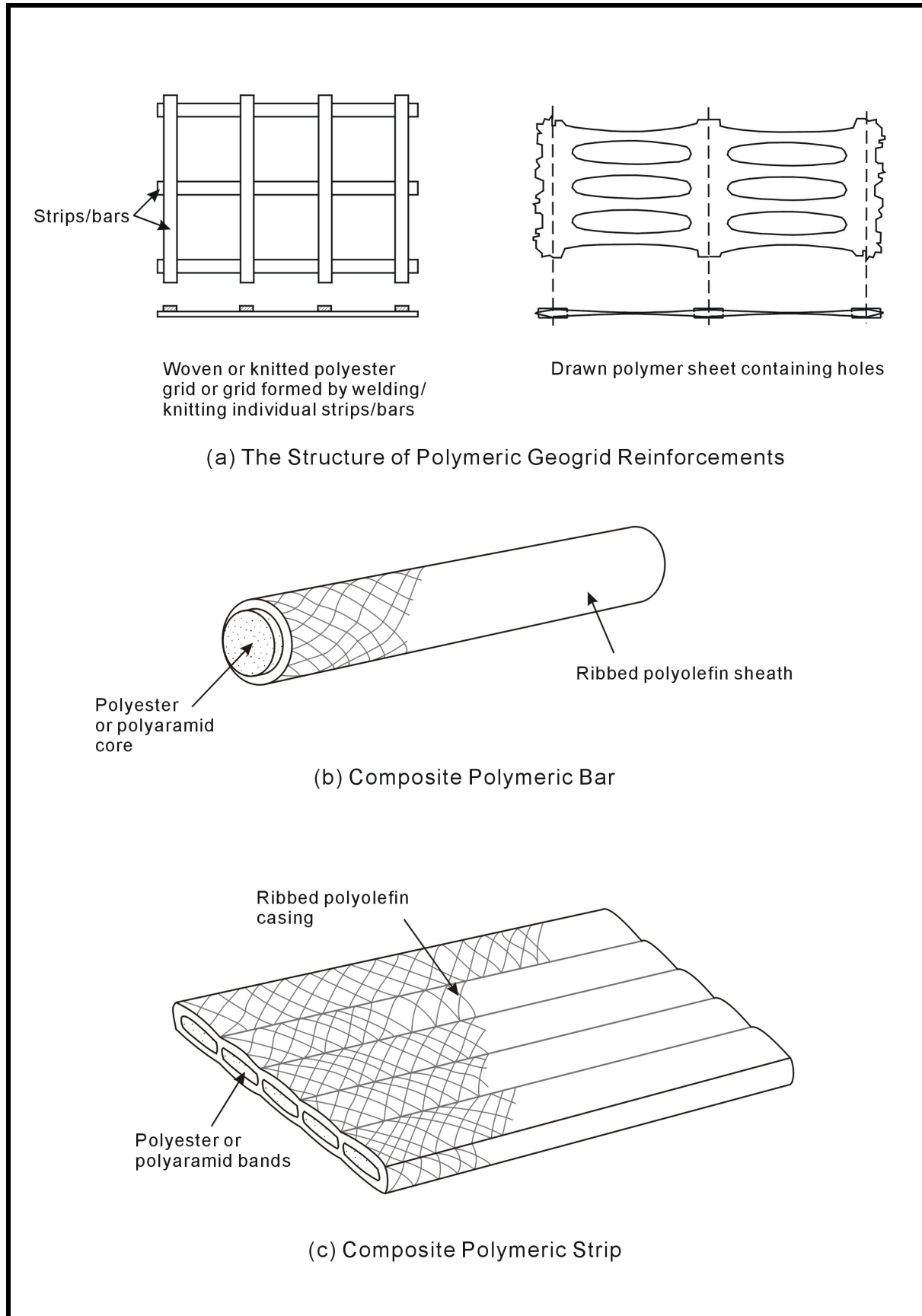
(b) Value of  $F_1$

Legend :

- $D_{50}$  particle size corresponding to 50% finer on the cumulative particle size distribution curve
- $F_1$  scale-effect factor for bearing ratio
- $h_a$  thickness of the reinforcing member
- $(\sigma'_b / \sigma'_n)$  bearing stress ratio

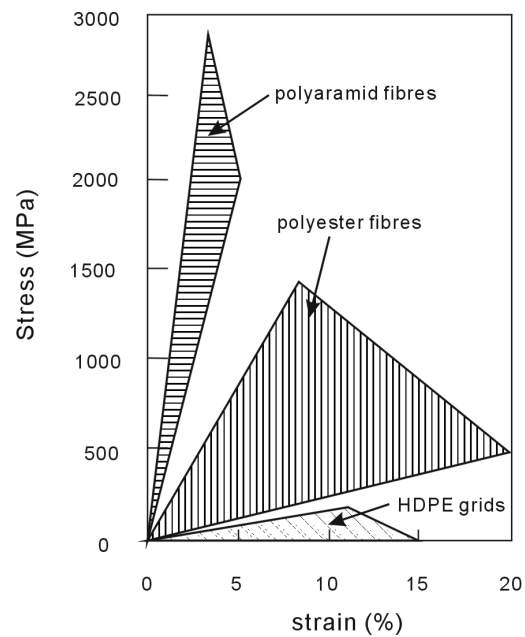
Note : Figure based on Palmeira & Milligan (1989) and Jewell (1990).

Figure 22 – Effect of Friction Angle and Particle Size on Pullout Resistance

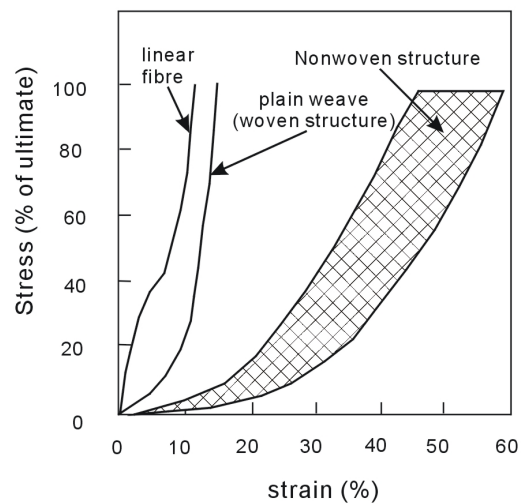


**Figure 23 – Polymeric Reinforcement**





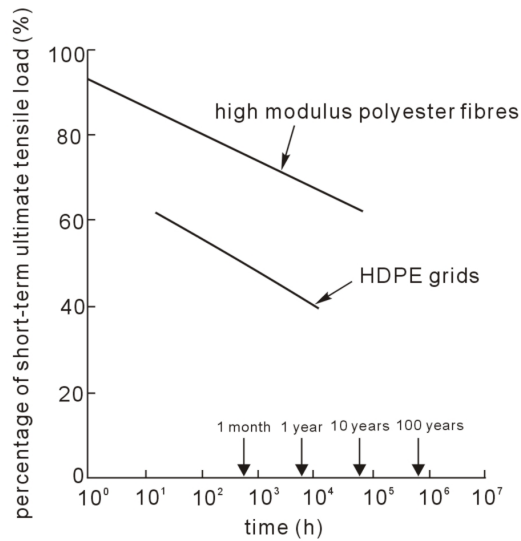
(a) Short-term Stress / Strain Characteristics of Different Polymeric Materials



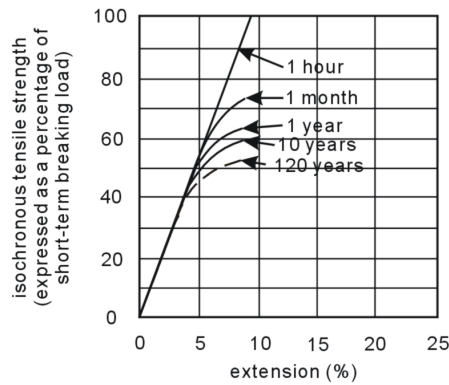
(b) Effect of Geometrical Structure on Stress / Strain Characteristics of Polyester Fibres

Note : Figure based on Lawson (1991).

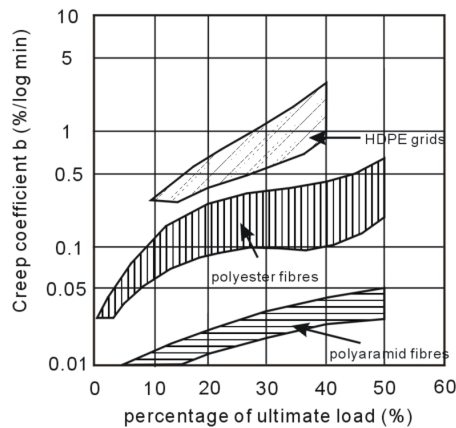
**Figure 24 – Typical Tensile Strength and Extension Characteristics of Polymeric Reinforcement**



(a) Stress-rupture Behaviour of Different Forms of Polymeric Reinforcement



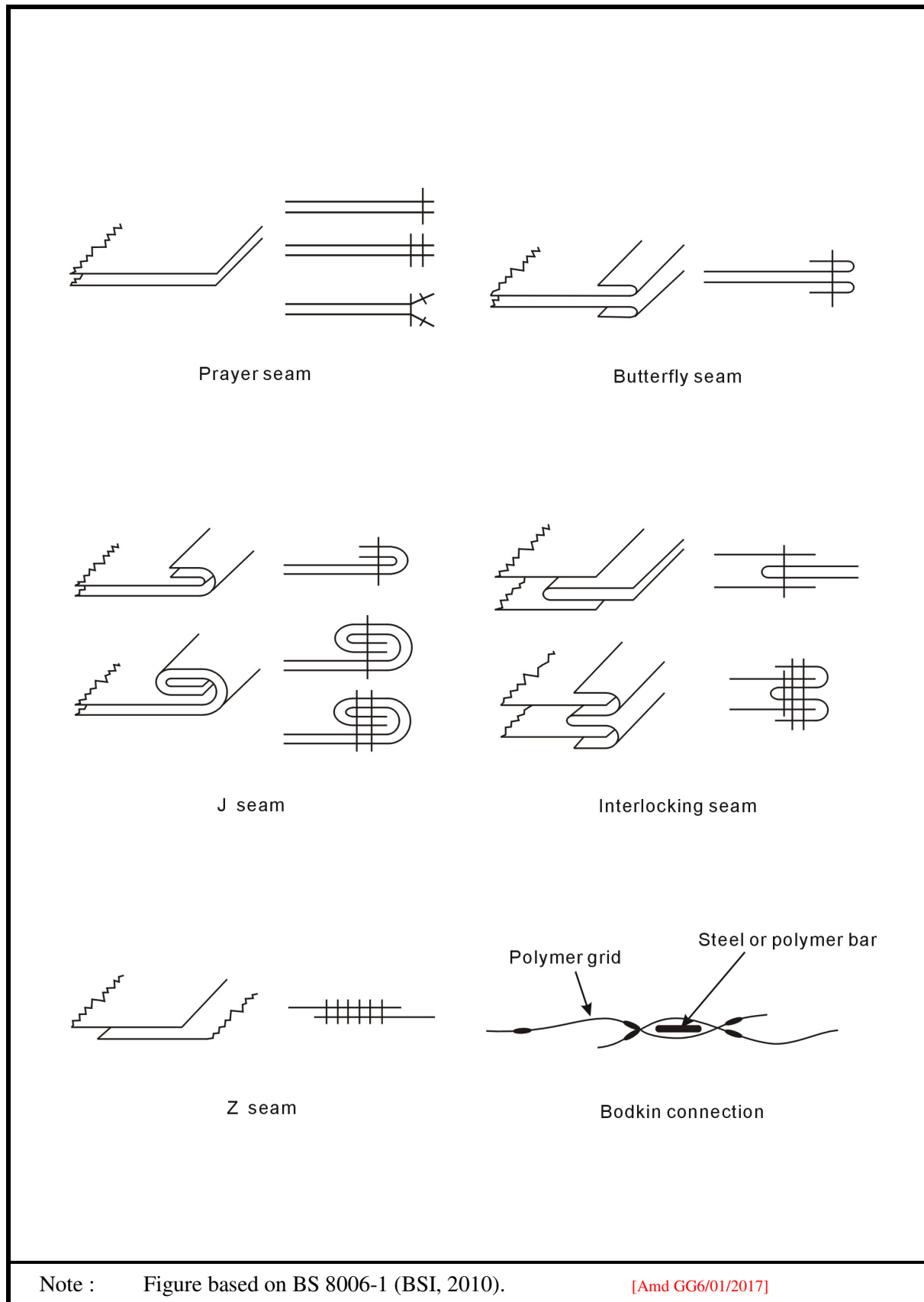
(b) Typical Isochronous Creep Curves for Polyester Strip Reinforcement



(c) Creep Coefficients Versus Percentage Applied Load for Various Polymeric Reinforcing Materials

Notes : (1) Figure based on ECGL (1989) and Hollaway (1990).  
 (2) All diagrams represent conditions at 23°C.

**Figure 25 – Typical Creep Curves of Different Polymeric Reinforcement**



**Figure 26 – Connections in Geotextiles and Polymeric Reinforcement**

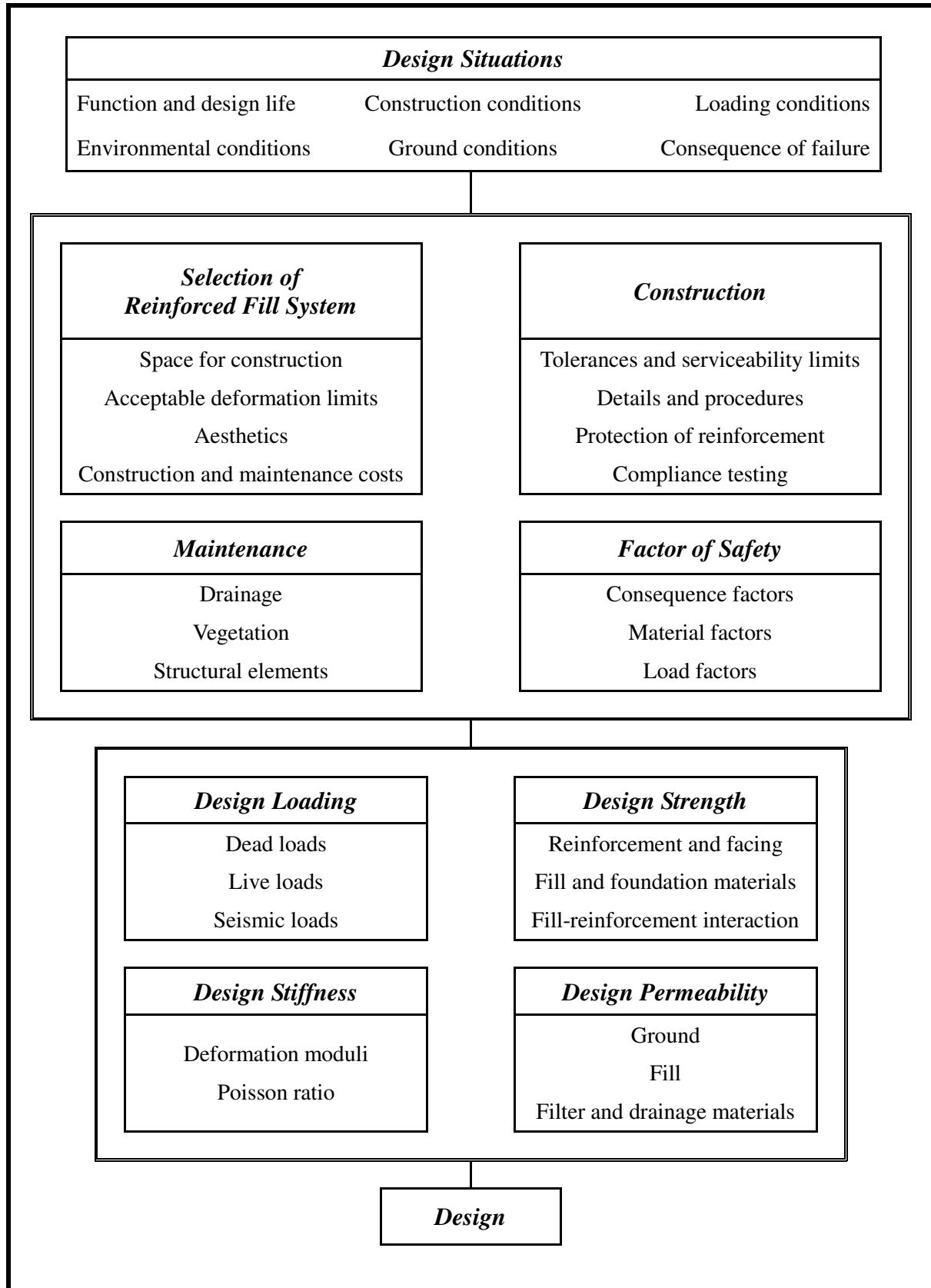
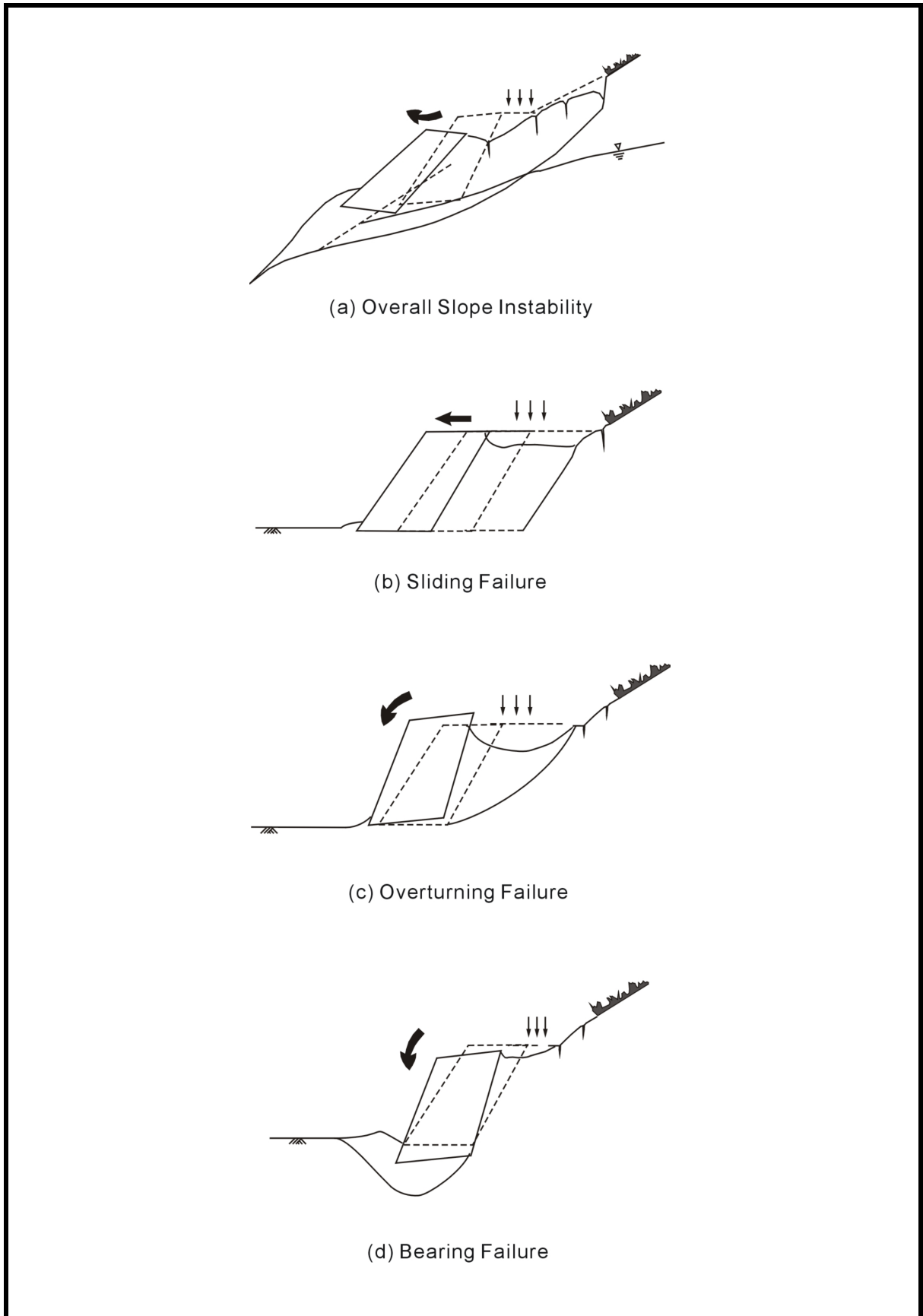
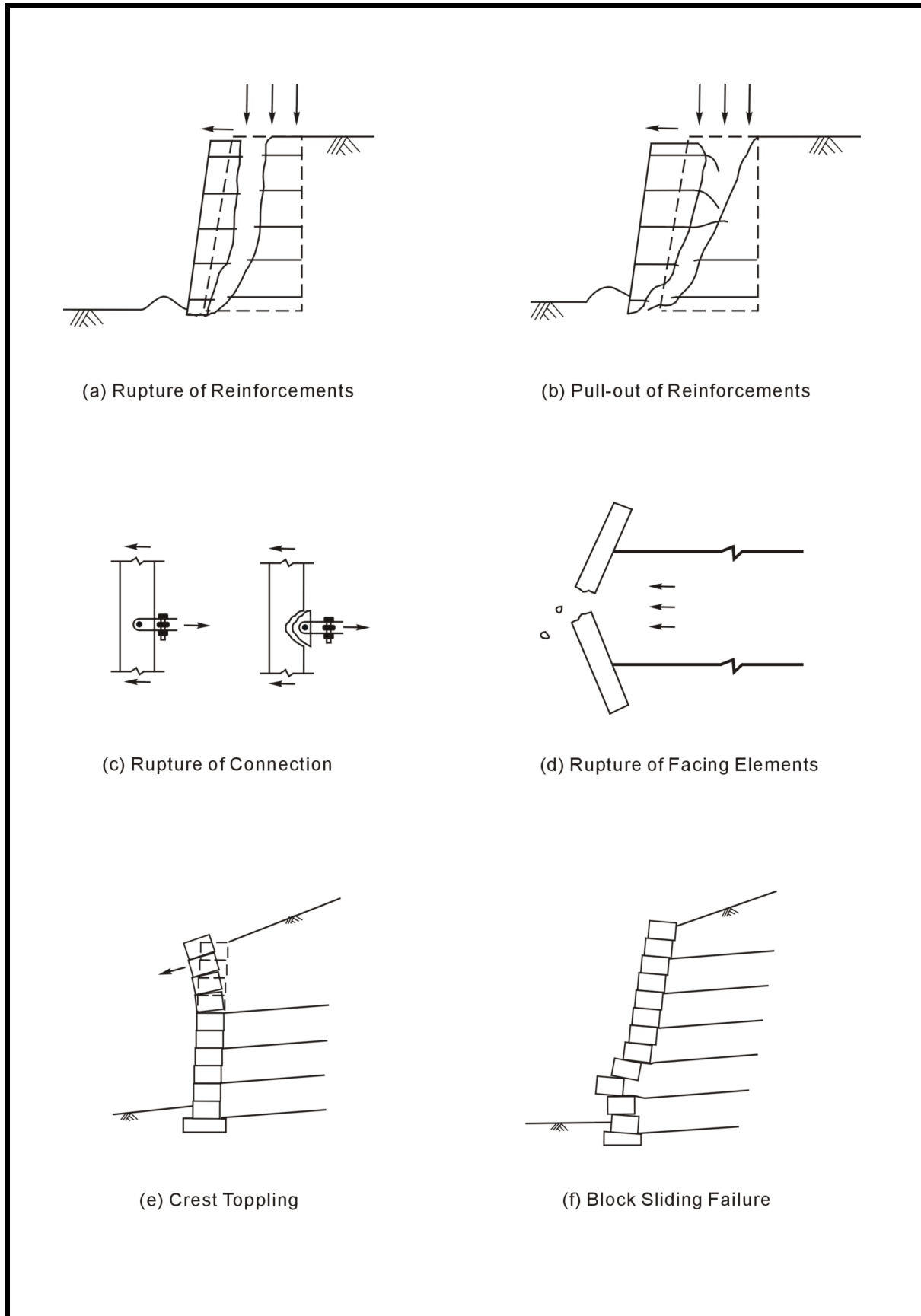


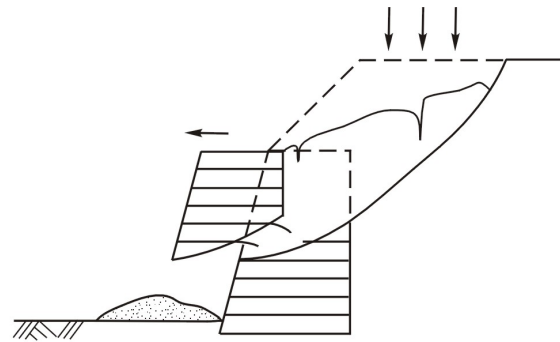
Figure 27 – Design Considerations for Reinforced Fill Structures and Slopes



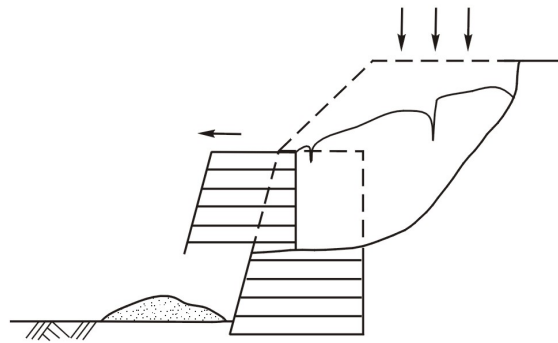
**Figure 28 – Ultimate Limit States - External Instability**



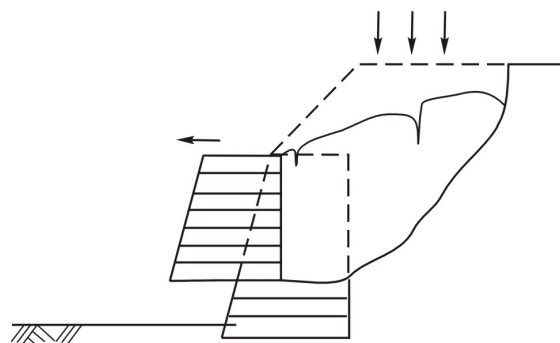
**Figure 29 – Ultimate Limit States - Internal Instability**



(a) Rupture / Pullout of Reinforcement

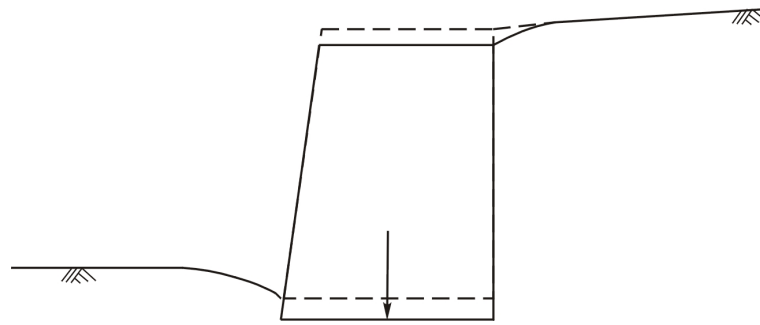


(b) Sliding on Planes between Reinforcement

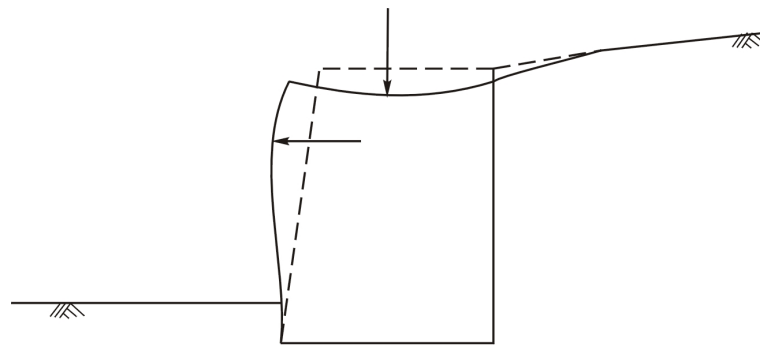


(c) Sliding along Reinforcement

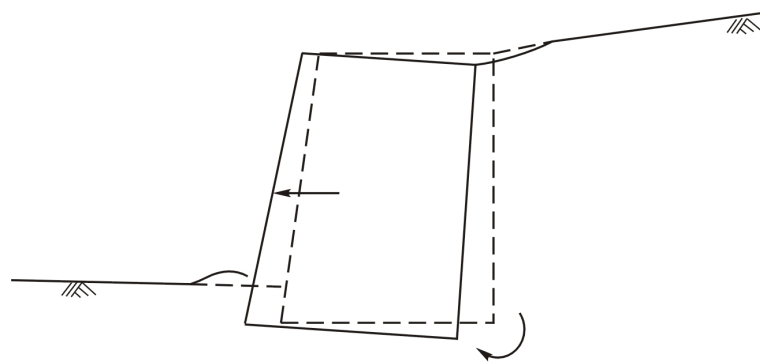
**Figure 30 – Ultimate Limit States - Compound Instability**



(a) Settlement



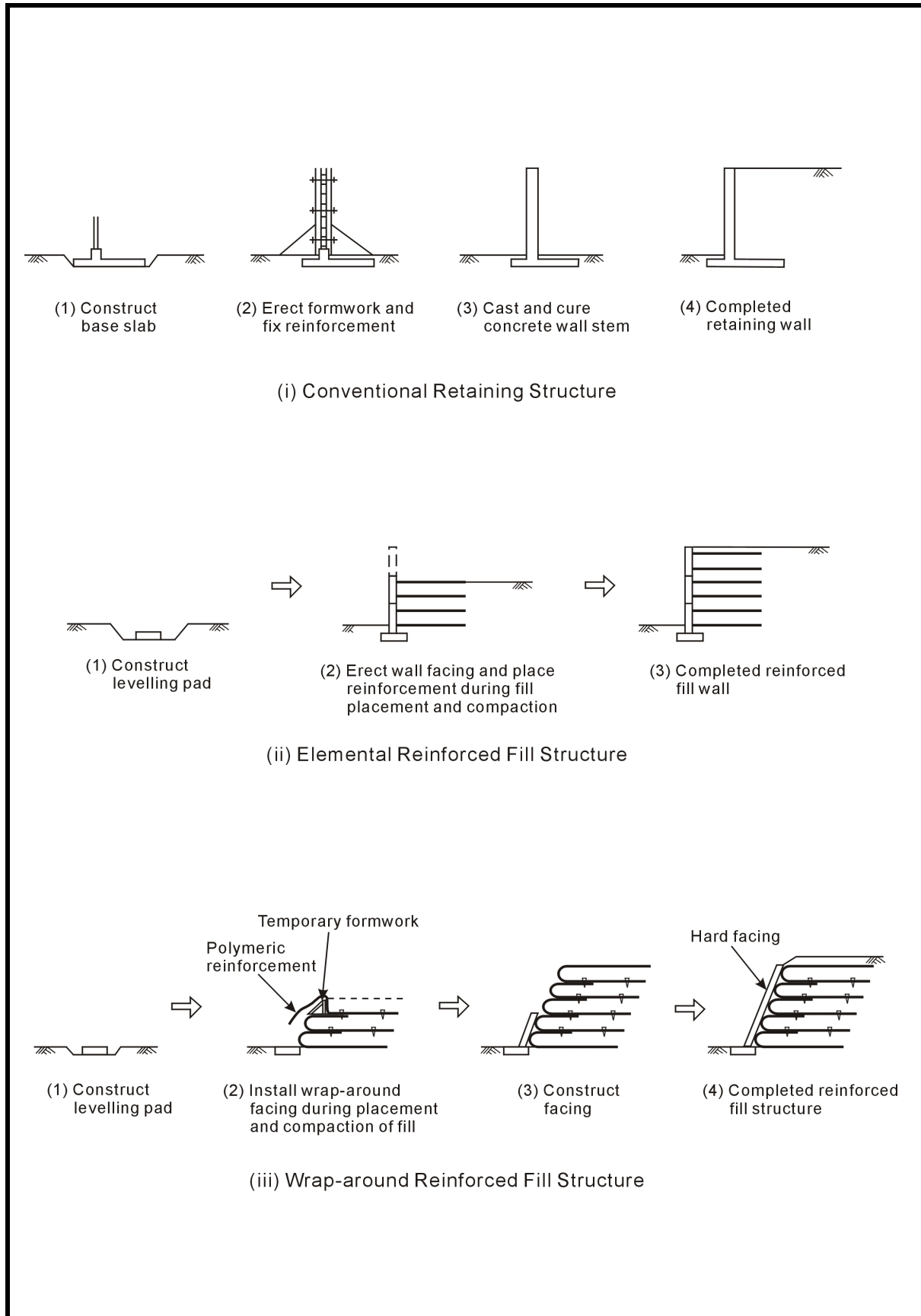
(b) Deformation of Reinforced Block



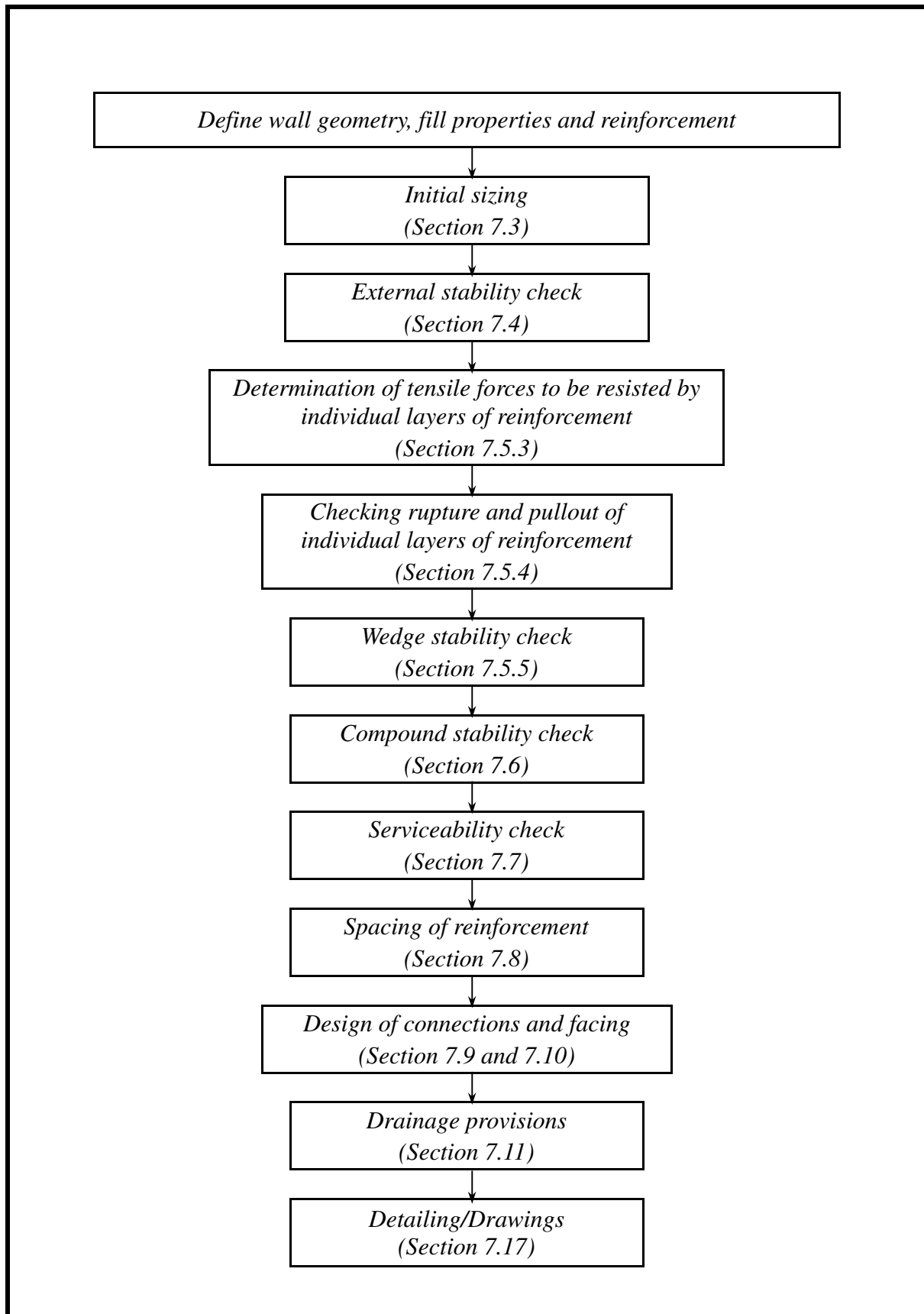
(c) Translation and Rotation

**Figure 31 – Serviceability Limit States**

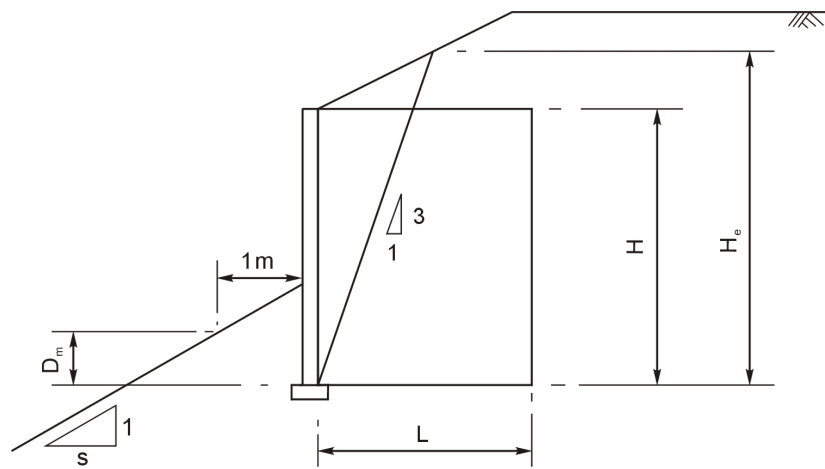




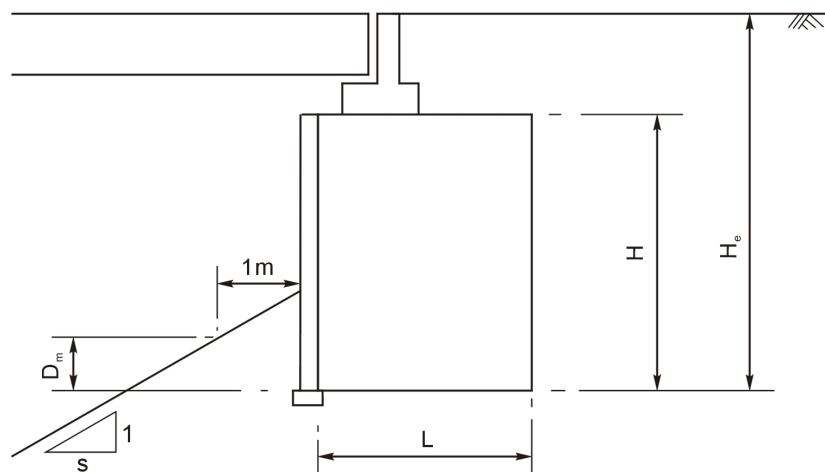
**Figure 32 – Construction Sequence of Earth Retaining Structures**



**Figure 33 – Design Procedure for Reinforced Fill Structures**



(a) Wall Supporting an Embankment



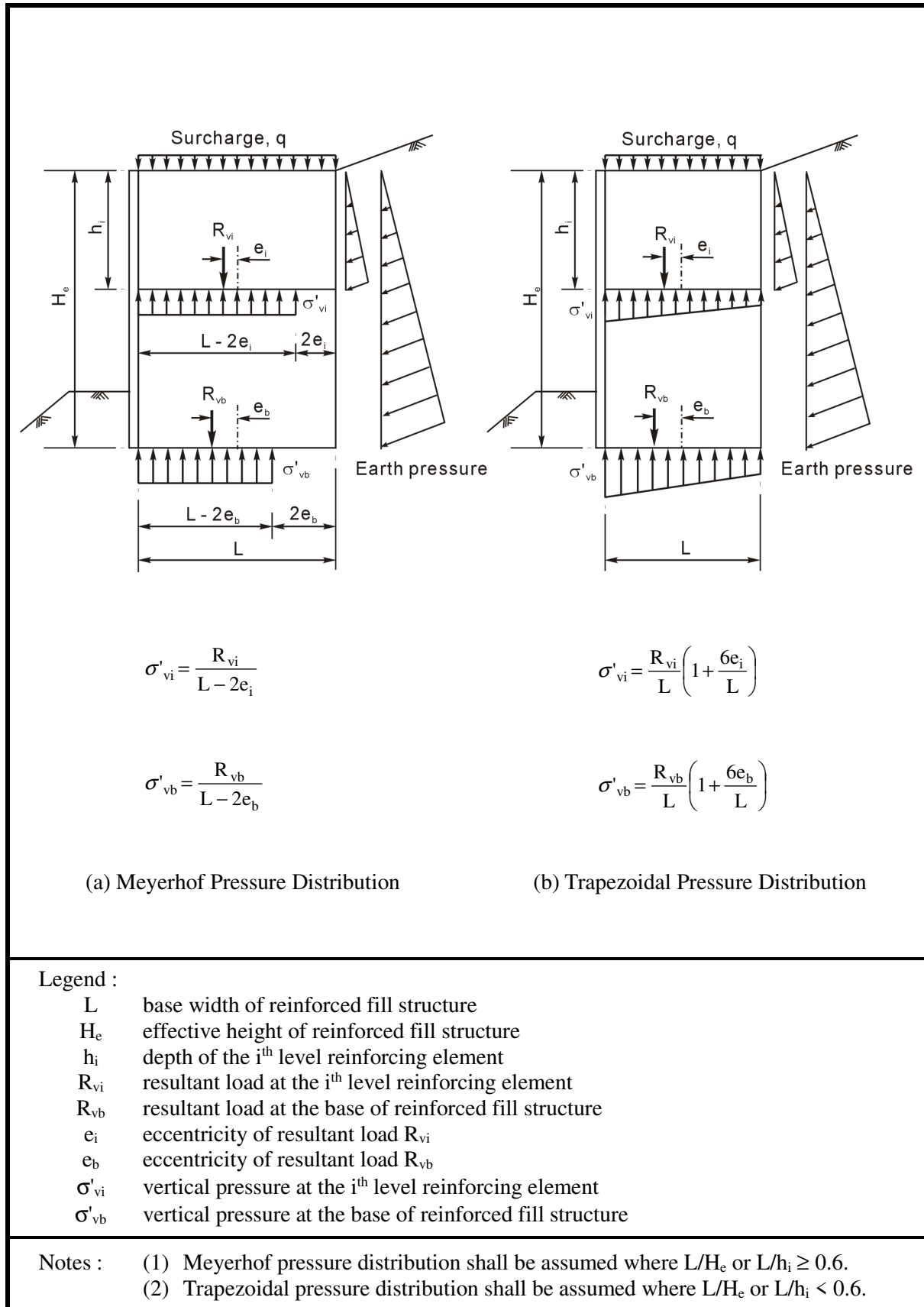
(b) Wall Supporting a Bridge Abutment

Legend :

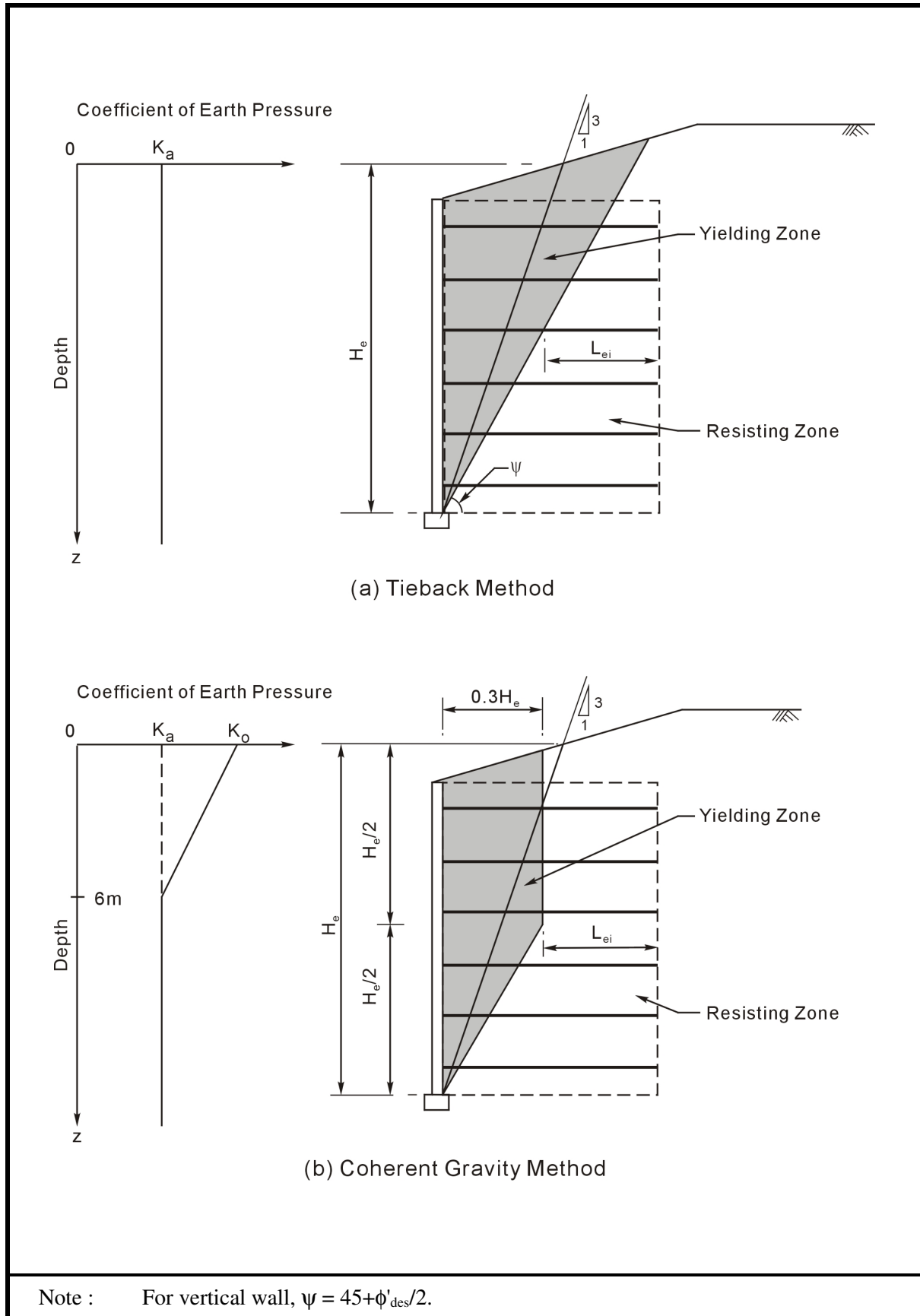
- $H_e$  effective wall height
- $D_m$  embedment depth
- $s$  slope gradient

- Notes :
- |                          |                                     |
|--------------------------|-------------------------------------|
| (1) For Initial Sizing,  | $L \geq 0.7H_e$ for walls           |
|                          | $L \geq (0.6H_e + 2)$ for abutments |
| (2) For Embedment depth, | $s = 3, \quad D_m \geq H_e / 10$    |
|                          | $s = 2, \quad D_m \geq H_e / 7$     |
|                          | $s = 1.5 \quad D_m \geq H_e / 5$    |

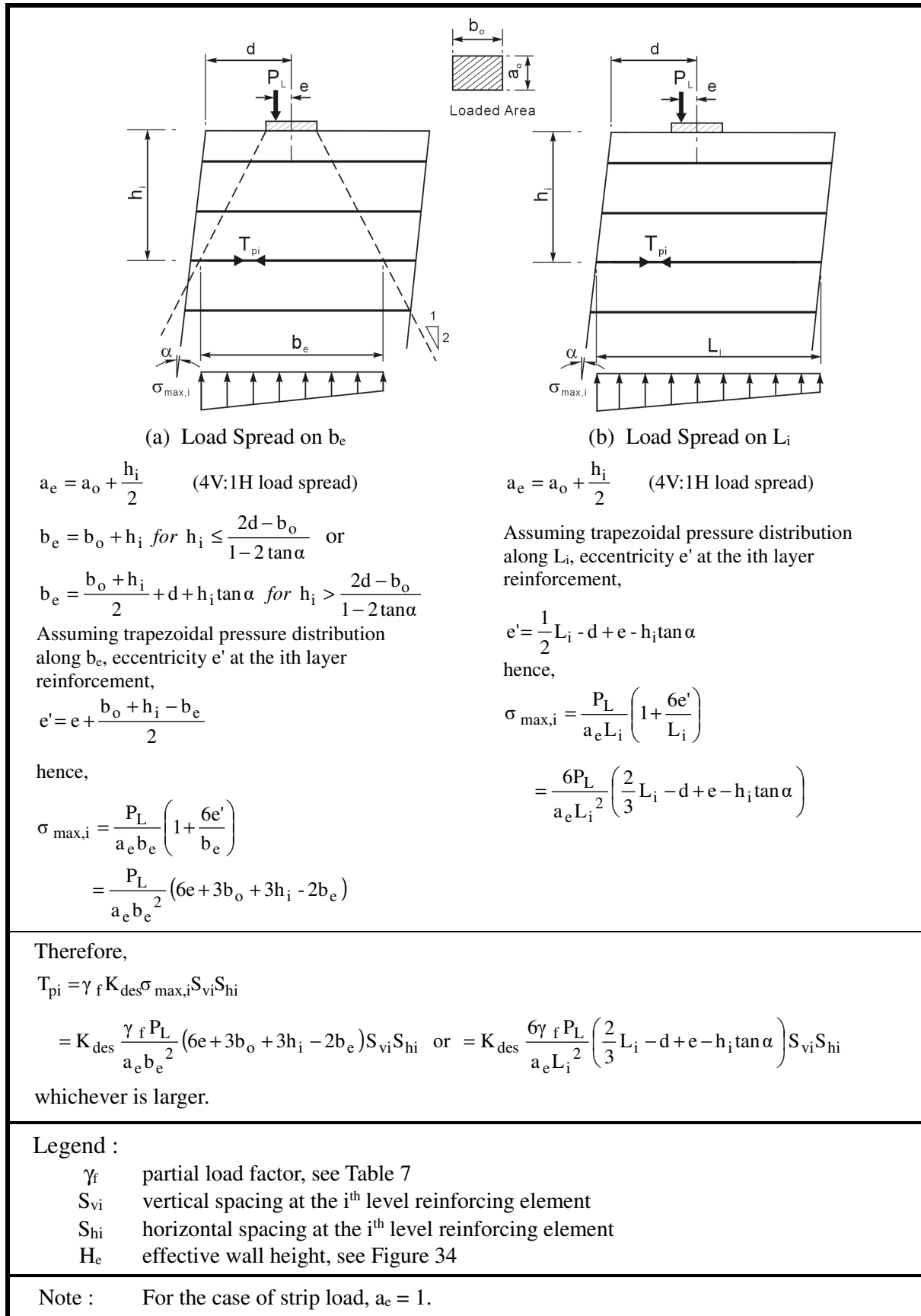
**Figure 34 – Initial Sizing and Embedment**



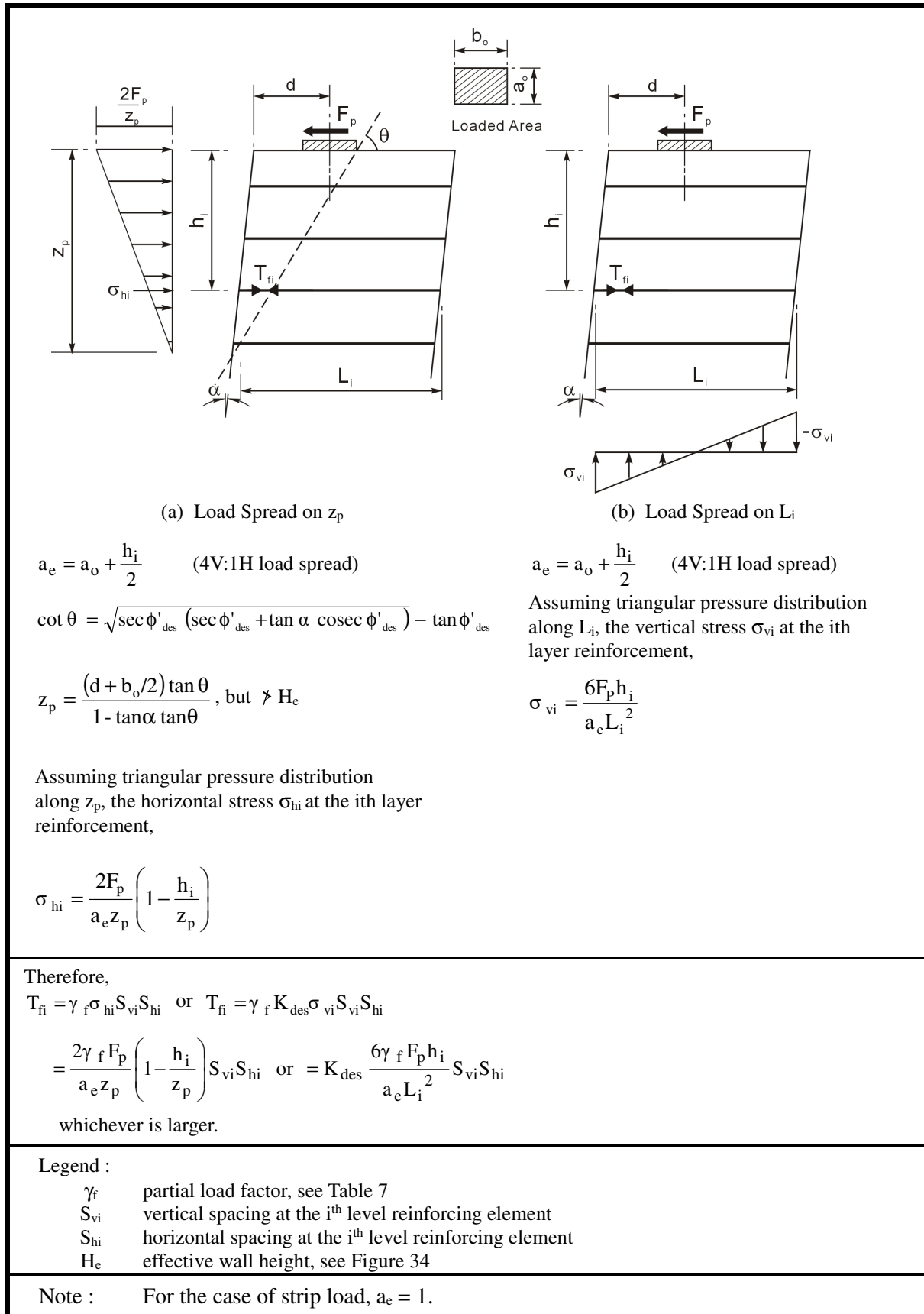
**Figure 35 – Stresses Imposed due to Self Weight, Surcharge and Retained Backfill**



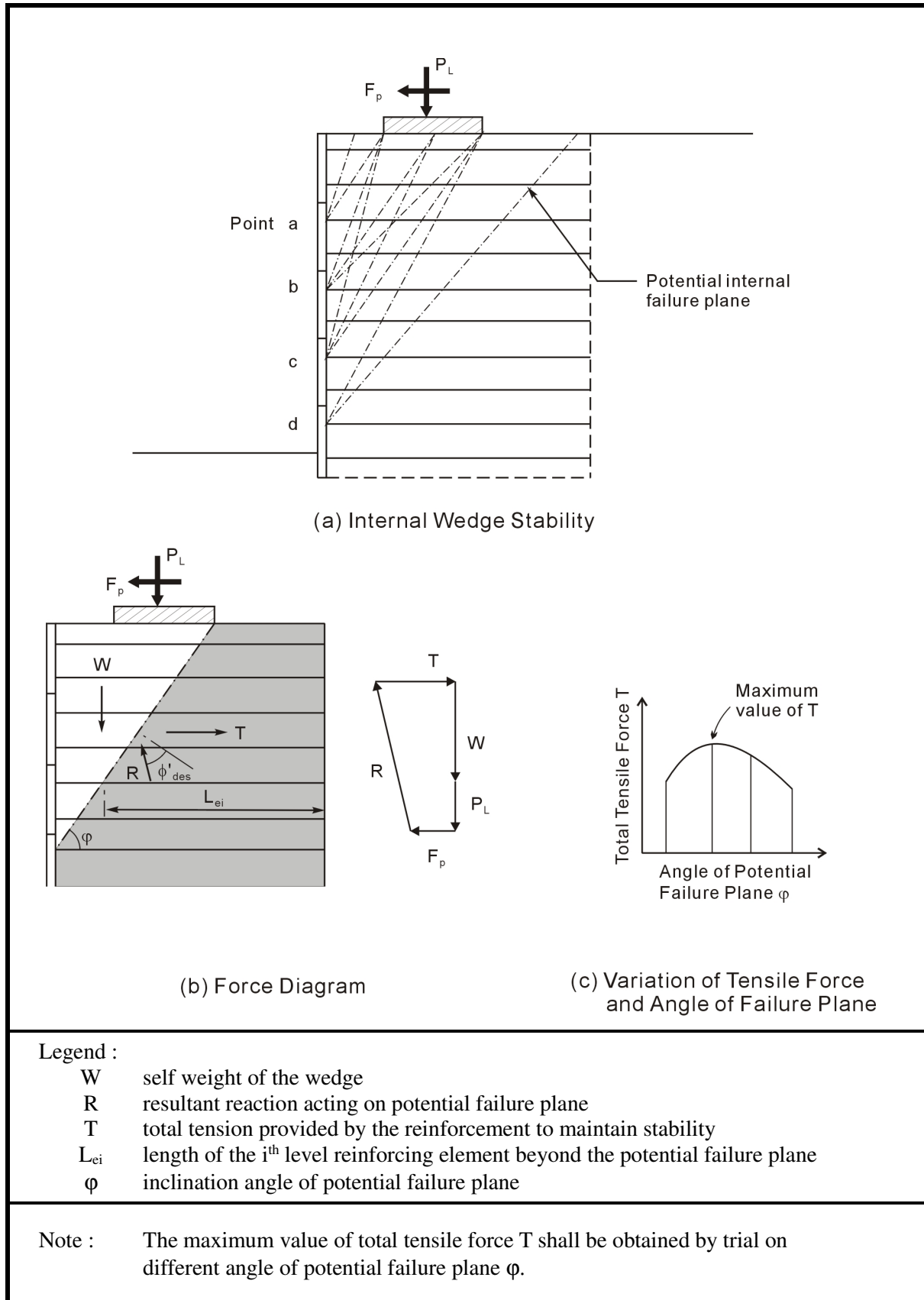
**Figure 36 – Design Methods for Internal Stability Analysis of Reinforced Fill Structures**



**Figure 37 – Tensile Force due to Vertical Load  $P_L$  on Top of the Structure**

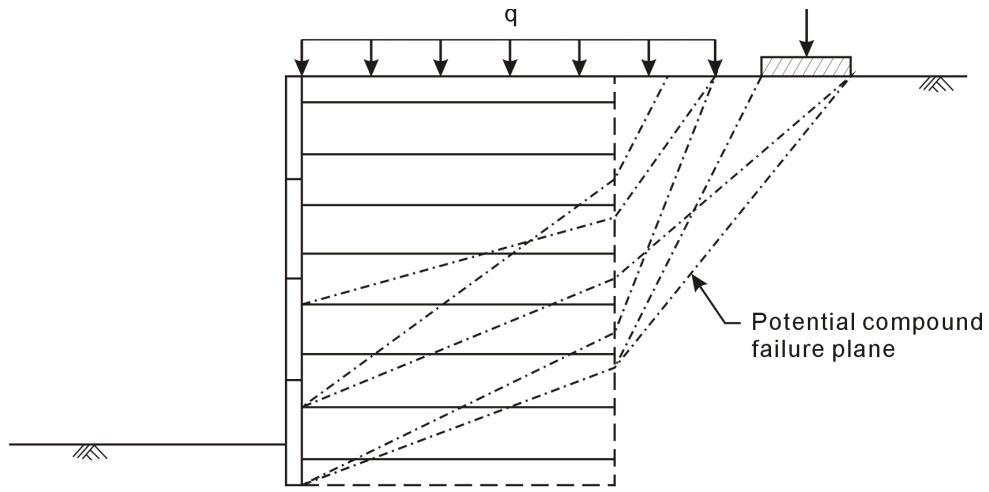


**Figure 38 – Tensile Force due to Horizontal Load  $F_p$  on Top of the Structure**

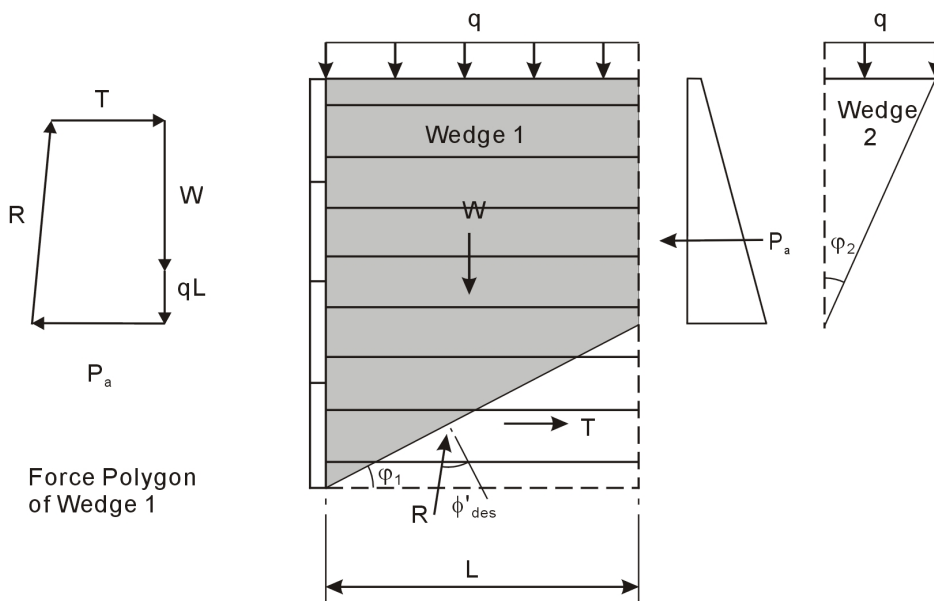


**Figure 39 – Internal Wedge Stability Analysis**





(a) Two Part Wedge Failure Mechanism



(b) Force Diagram

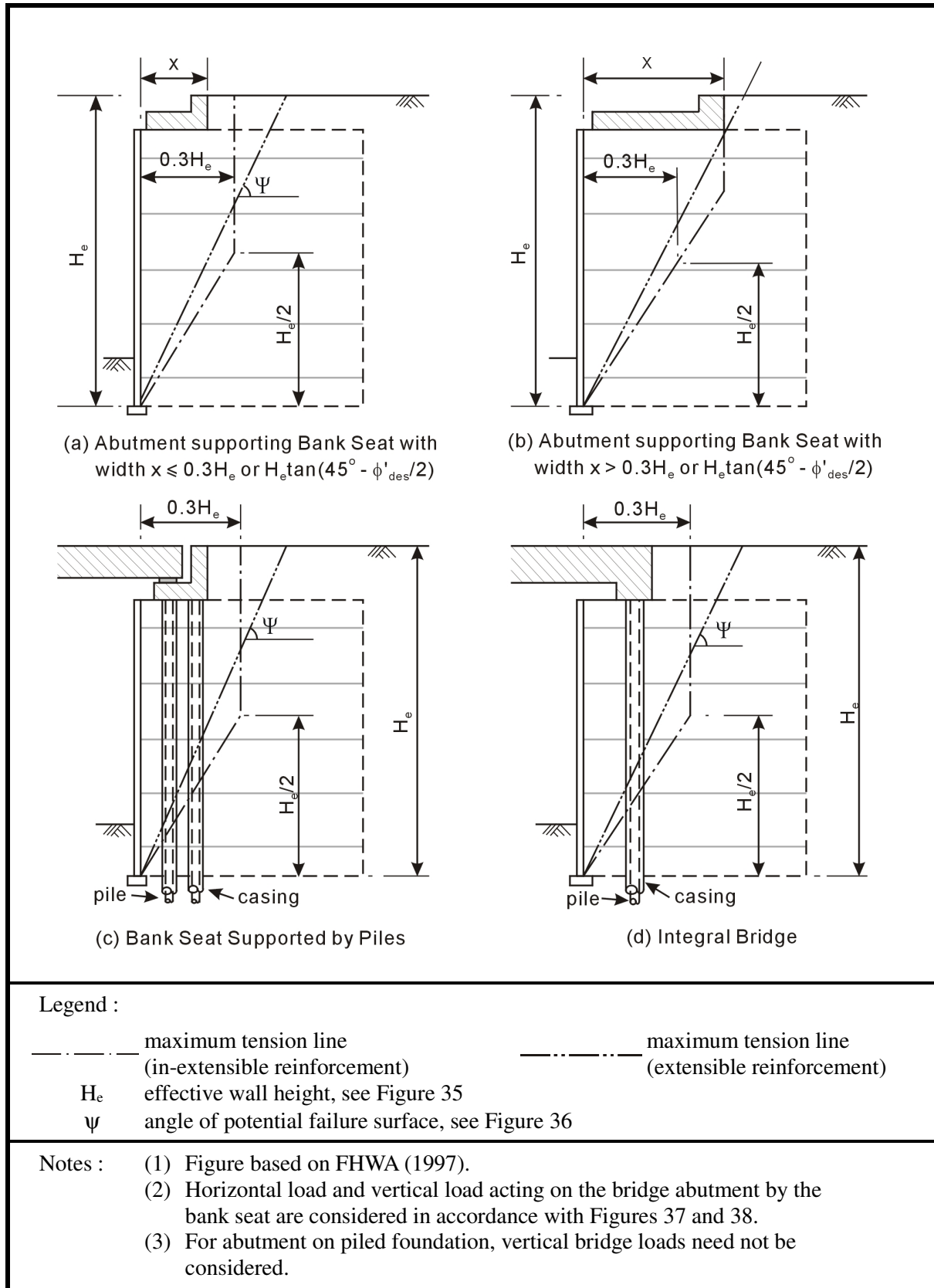
Legend :

$P_a$  resultant active force acting on Wedge 1 due to Wedge 2

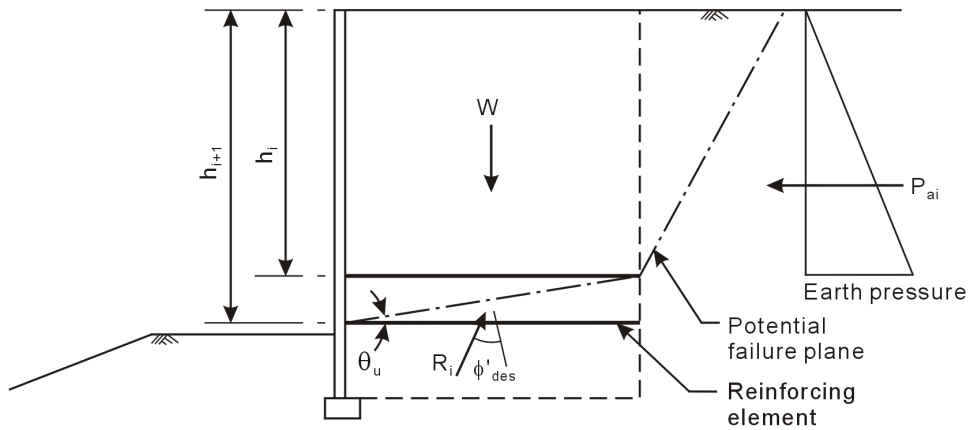
$\phi$  inclination angle of potential failure wedge

- Notes :
- (1) The maximum value of total tensile force T shall be obtained by trial on different combination in angle of potential failure plane  $\phi_1$  and  $\phi_2$ .
  - (2) Inter-wedge shear force between Wedge 1 and Wedge 2 may be a stabilising force or a destabilising force, see Section 7.6.2.

**Figure 40 – Compound Wedge Stability Analysis using Two-part Wedge Method**

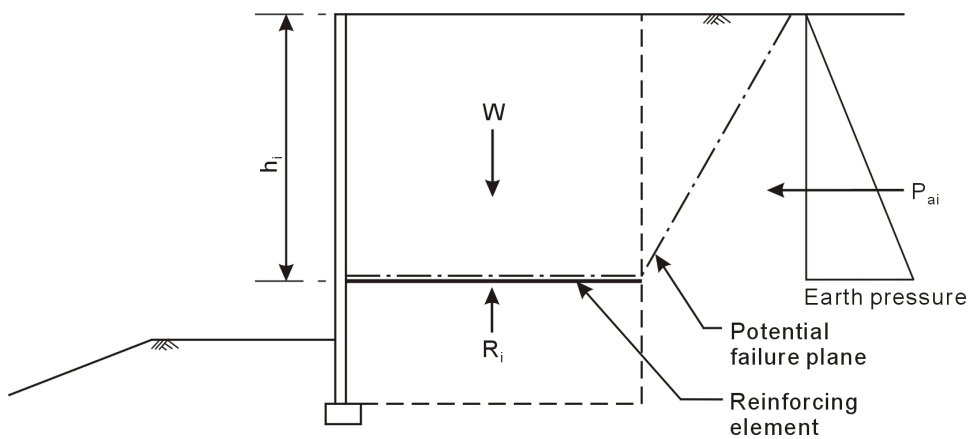


**Figure 41 – Geometry and Maximum Tension Lines for Bridge Abutments and Piled Bank Seat**



Stability requirement:  $W \tan(\phi'_{des} - \theta_u) \geq P_{ai}$

(a) Slide on Plane between Reinforcement



Stability requirement:  $W \mu_{dsD} \geq P_{ai}$

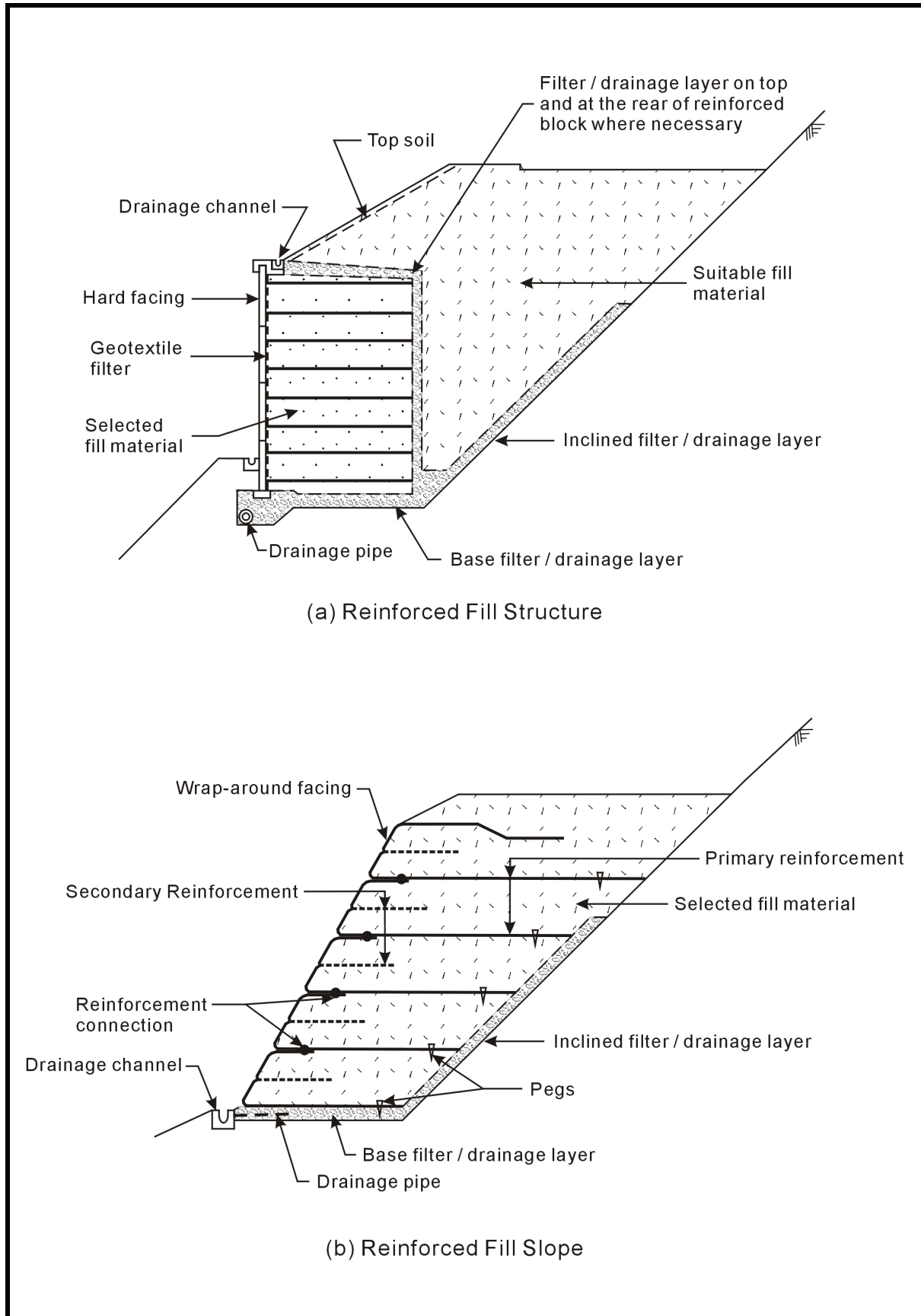
(b) Slide Along Reinforcement

Legend :

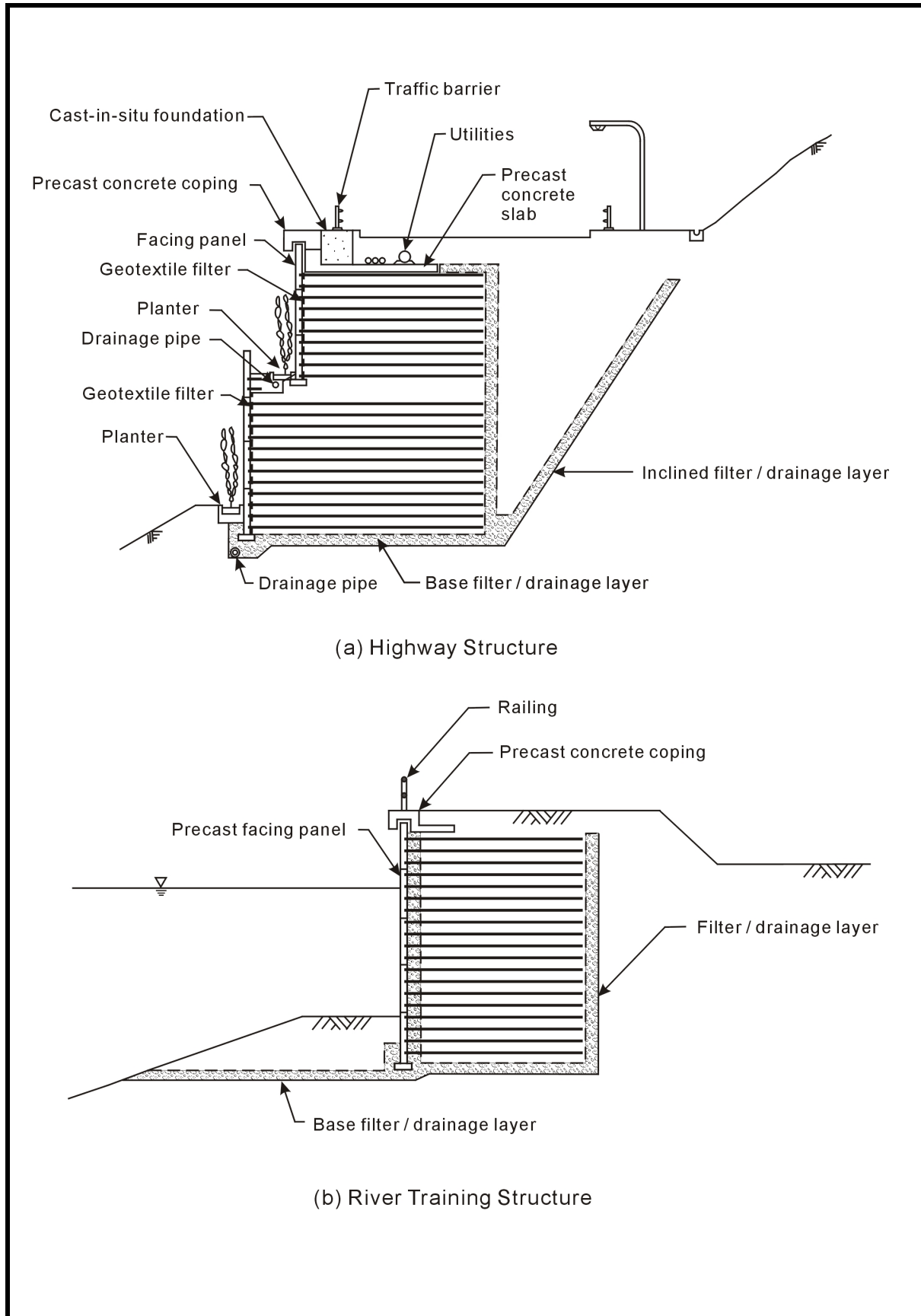
- $h_i, h_{j+1}$  depth of the  $i^{th}$  and  $i+1^{th}$  level reinforcing elements
- $P_{ai}$  resultant active force acting on the reinforced block due to retained backfill
- $R_i$  resultant reaction force acting on the potential failure plane
- $\mu_{dsD}$  design coefficient of friction against sliding between reinforcement and fill
- $\theta_u$  angle of the steepest plane between any two layer of reinforcement

- Notes :
- (1) The effect of groundwater shall be considered in the analysis.
  - (2) Inter-wedge shear force between Wedge 1 and Wedge 2 may be a stabilising force or a destabilising force, see Section 7.6.2.

Figure 42 – Compound Stability Analysis



**Figure 43 – Typical Drainage Layouts for Reinforced Fill Structures and Slopes**



**Figure 44 – Typical Drainage Layouts for Highway and River Training Applications**

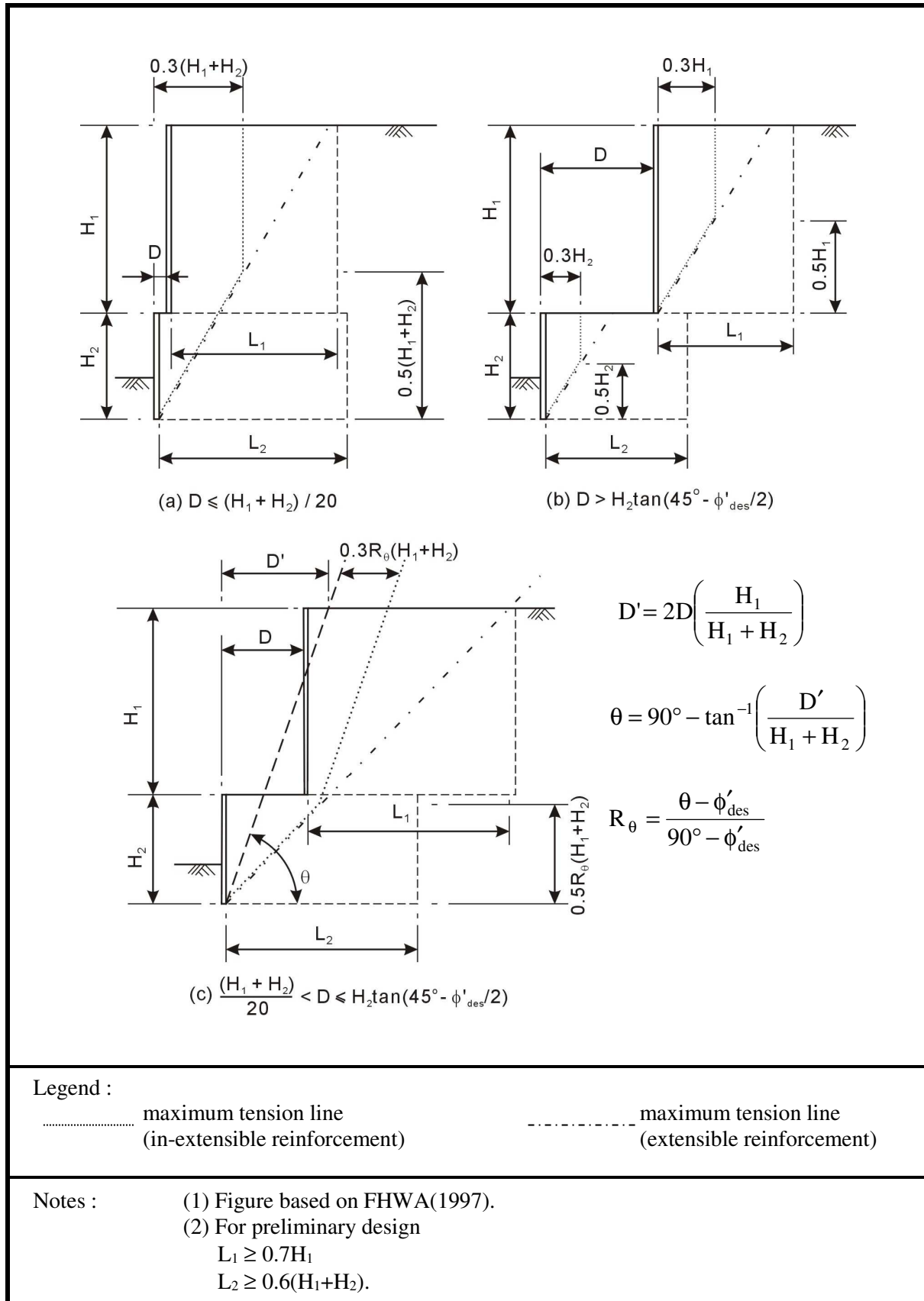
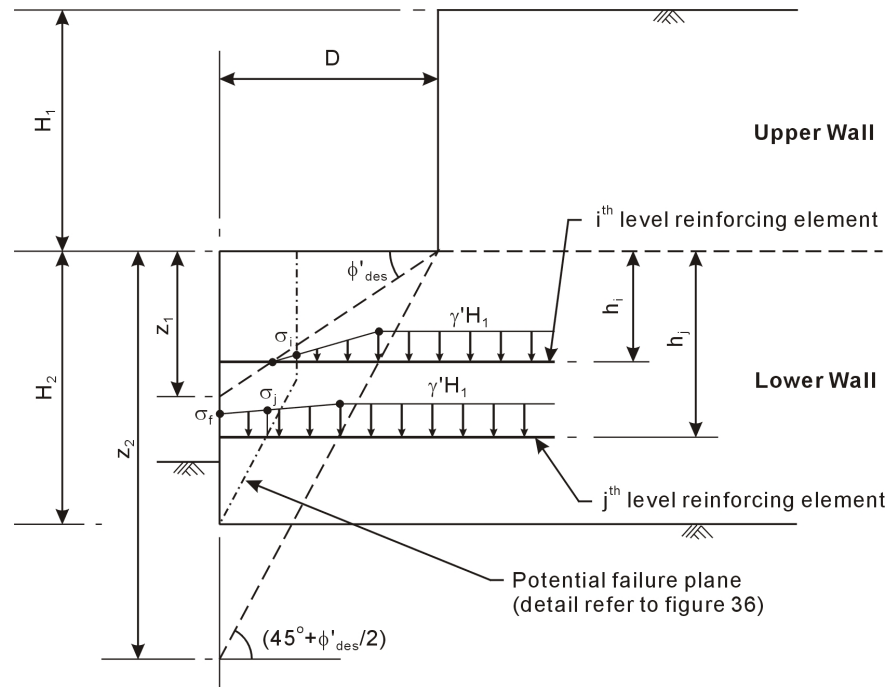


Figure 45 – Definition and Location of Maximum Tension Lines of Superimposed Walls

Case 1 :  $H_2 \tan(45^\circ - \frac{\phi'_{des}}{2}) < D \leq H_2 \tan(90^\circ - \phi'_{des})$



where  $z_1 = D \tan \phi'_{des}$   
 $z_2 = D \tan(45^\circ + \frac{\phi'_{des}}{2})$   
 $\sigma_f = \frac{h_j - z_1}{z_2 - z_1} \gamma' H_1$

Case 2 :  $D \leq H_2 \tan(45^\circ - \frac{\phi'_{des}}{2})$

$$\sigma_i = \sigma_j = \gamma' H_1$$

Case 3 :  $D > H_2 \tan(90^\circ - \phi'_{des})$

$$\sigma_i = \sigma_j = 0$$

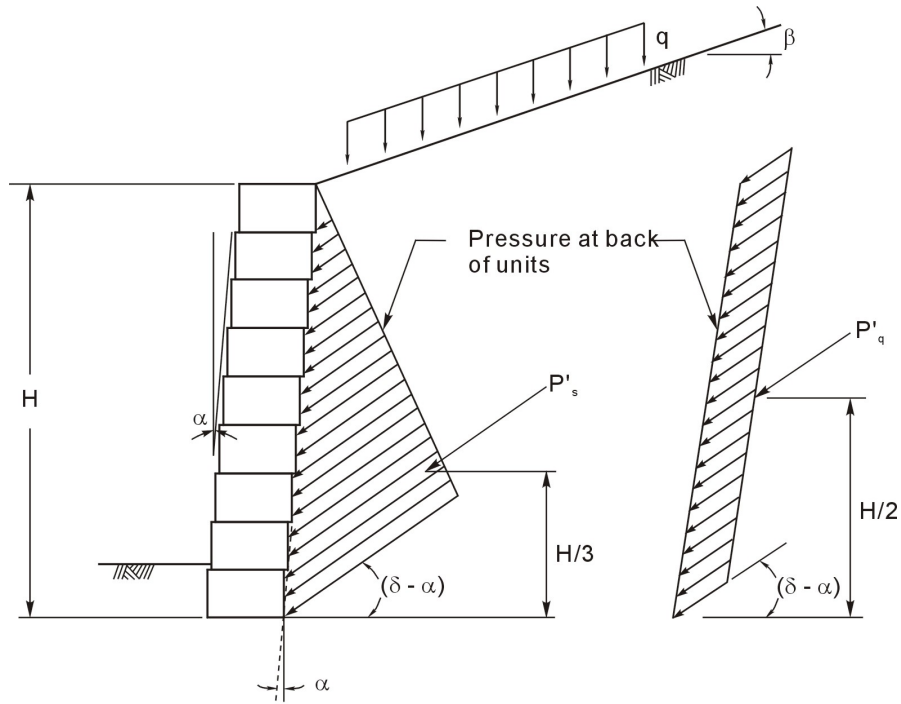
Legend :

$h_i, h_j$  depth of the  $i^{\text{th}}$  and  $j^{\text{th}}$  level reinforcing elements

$\sigma_i, \sigma_j$  additional vertical stress on the  $i^{\text{th}}$  and  $j^{\text{th}}$  level reinforcing elements

Note : Figure based on FHWA (1997).

**Figure 46 – Additional Vertical Stress on Reinforcement for Superimposed Wall**



$$P'_s = 0.5K_a\gamma'H$$

$$P'_q = K_aqH$$

$$K_a = \frac{\cos^2(\phi' + \alpha)}{\cos^2\alpha \cos(\delta - \alpha) \left[ 1 + \sqrt{\frac{\sin(\phi' + \delta)\sin(\phi' - \beta)}{\cos(\delta - \alpha)\cos(\beta + \alpha)}} \right]^2}$$

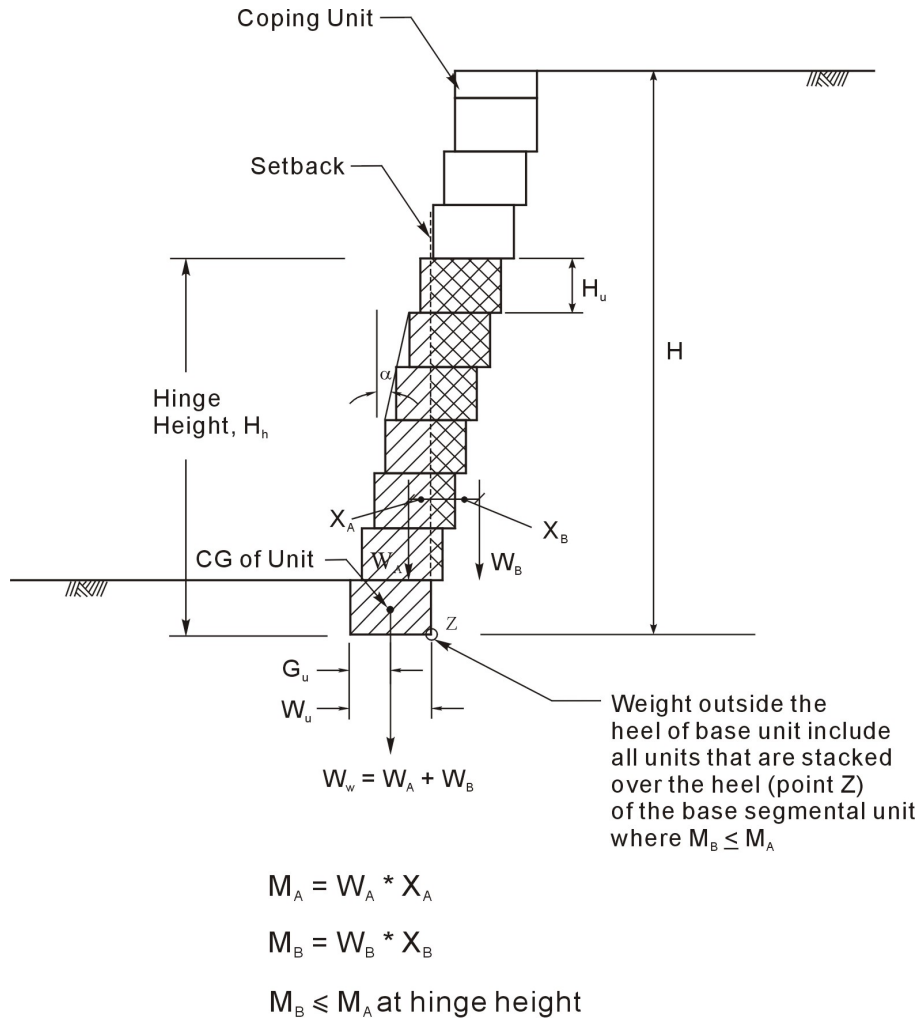
Legend :

- $\alpha$  wall batter
- $\delta$  interface friction angle
- $\beta$  backslope angle

Note : Reinforcement not shown on drawing for clarity.

Figure 47 – Geometry and Earth Pressure Distribution of Segmental Block Wall



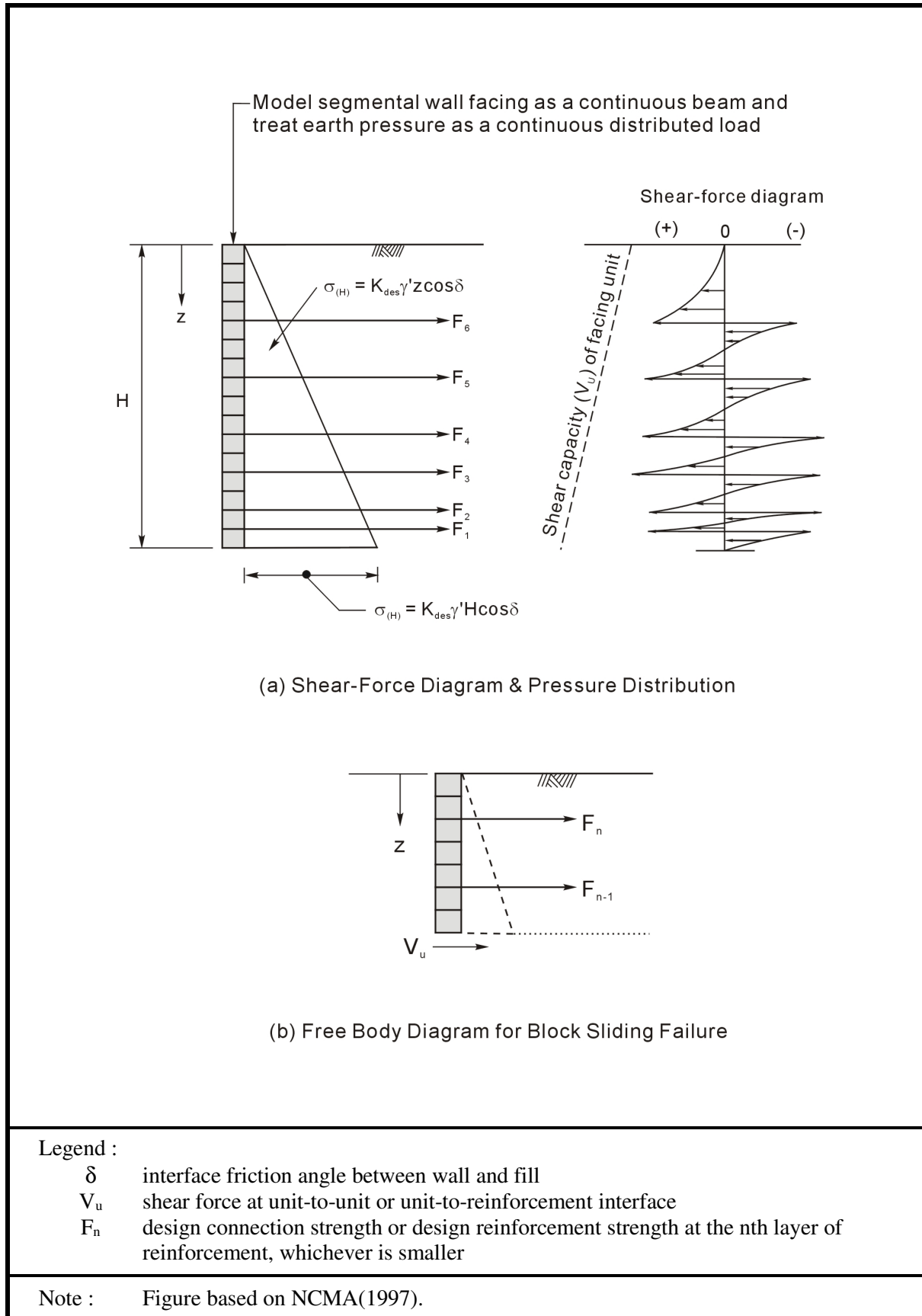


Legend :

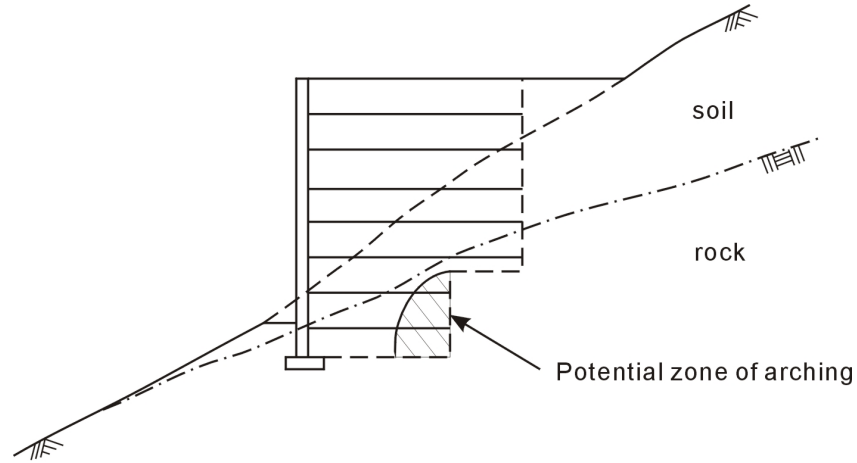
- H height of segmental block wall
- $H_u$  height of segmental block unit
- $H_h$  hinge height
- $W_u$  width of segmental block unit

- Notes :
- (1) Figure based on NCMA(1997).
  - (2) The full weight of all units within  $H_h$  will be considered to act at the base of the lowermost unit.

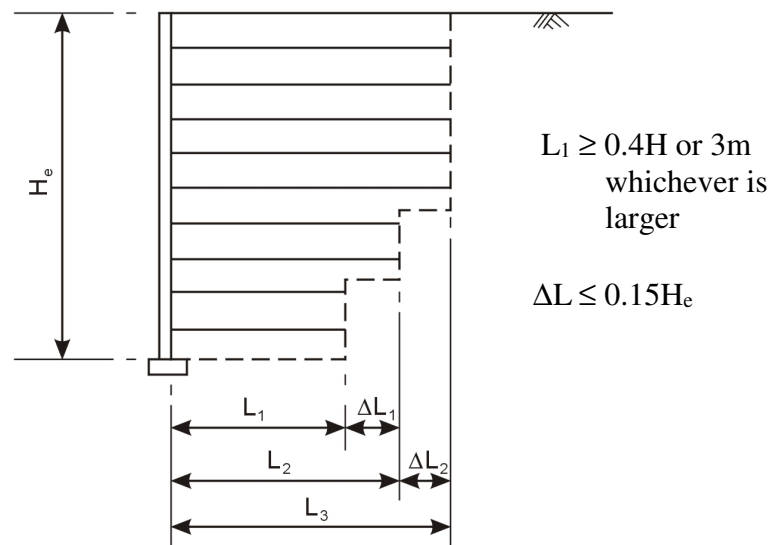
Figure 48 – Hinge Height for Segmental Block Wall Design



**Figure 49 – Analysis of Block Sliding Failure of Segmental Block Wall**



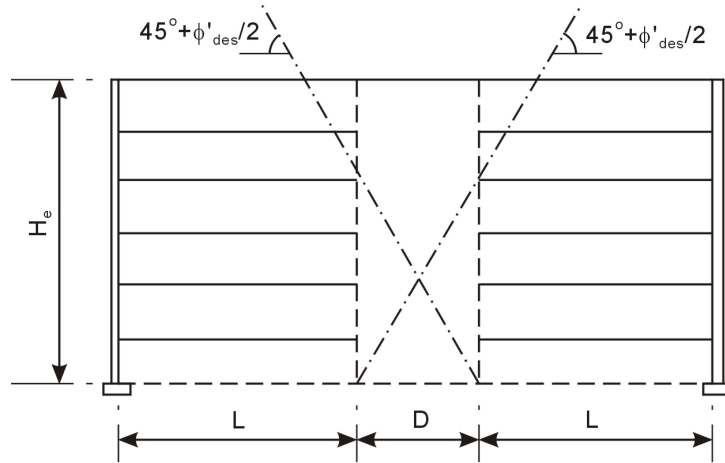
(a) Arching in Reinforced Fill Wall



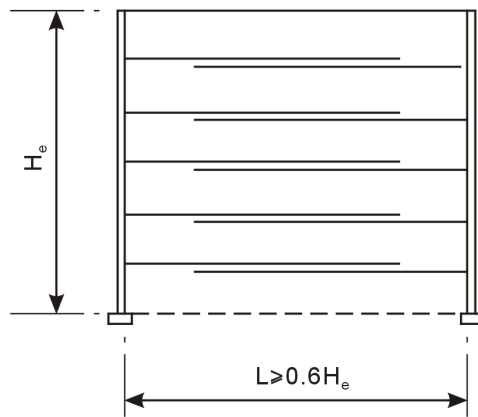
(b) Initial Sizing of Trapezoidal Wall

- Notes :
- (1) The presence of drainage layers at the back wall steps may reduce vertical loading on the reinforcement.
  - (2) Compaction at the edge of steps is critical.

**Figure 50 – Walls with a Stepped Base**



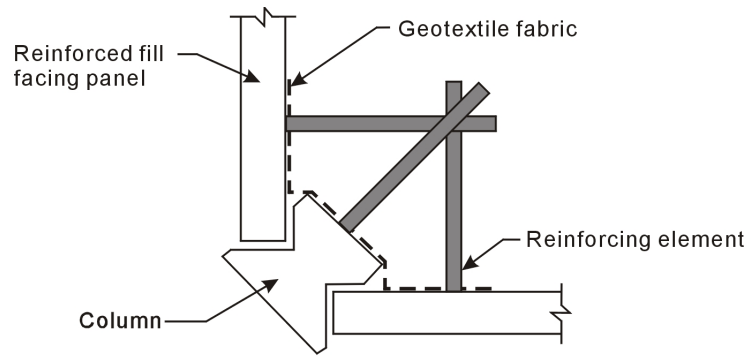
(a) Back-to-Back Wall with No Overlapping of Reinforcement



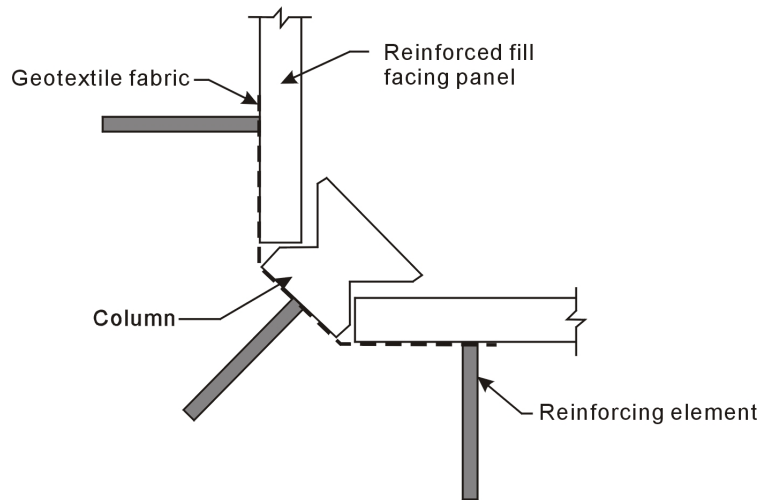
(b) Back-to-Back Wall with Overlapping of Reinforcement

- Notes :
- (1) For Back-to-Back Wall with no overlapping of reinforcement, the reduction in active thrust could be ignore to simplify the calculation.
  - (2) For Back-to-Back Wall with overlapping of reinforcement, the walls should be considered as a single structure for external stability. For internal stability, no active thrust in the backfill is assumed.

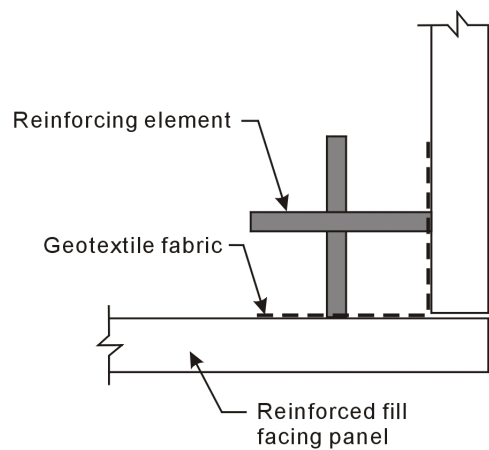
**Figure 51 – Back-to-Back Walls**



(a) External Corner with Column

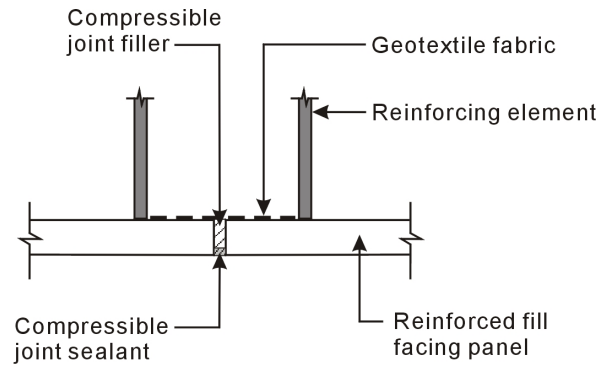


(b) Internal Corner with Column

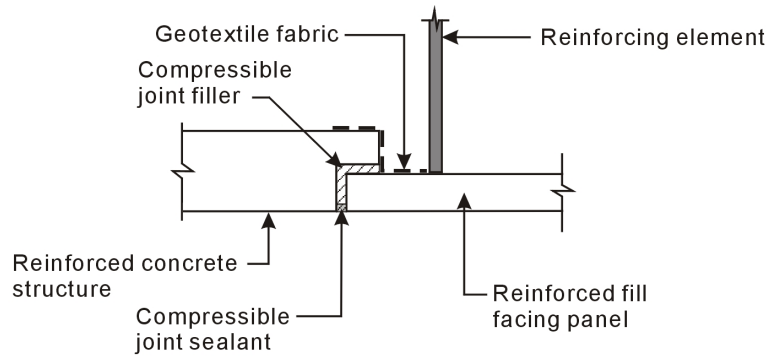


(c) Corner without Column

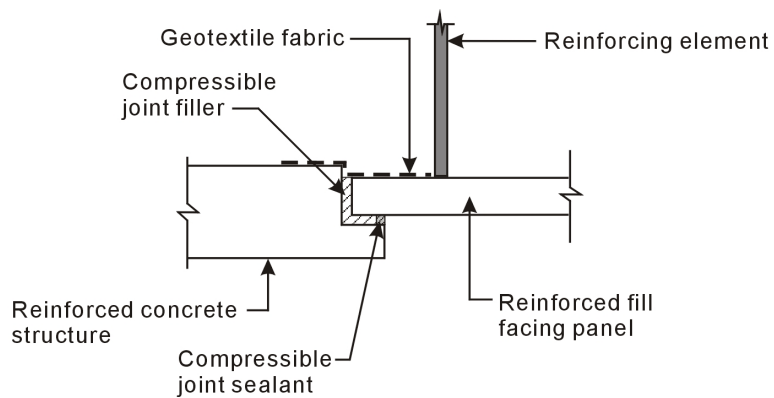
**Figure 52 – Typical Corner Details of Reinforced Fill Structures**



(a) Movement Joint

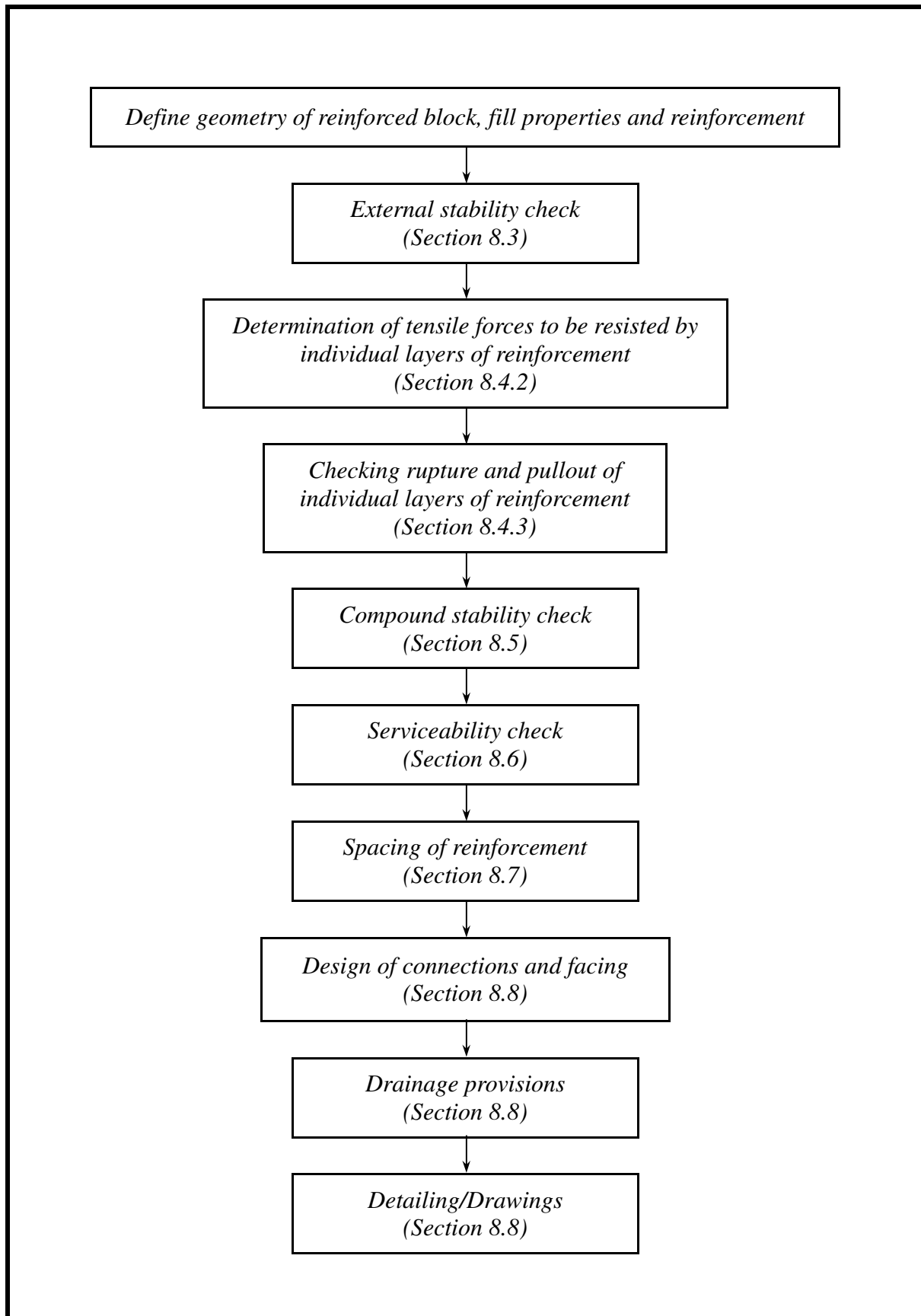


(b) Movement Joint abutting Reinforced Concrete Structure

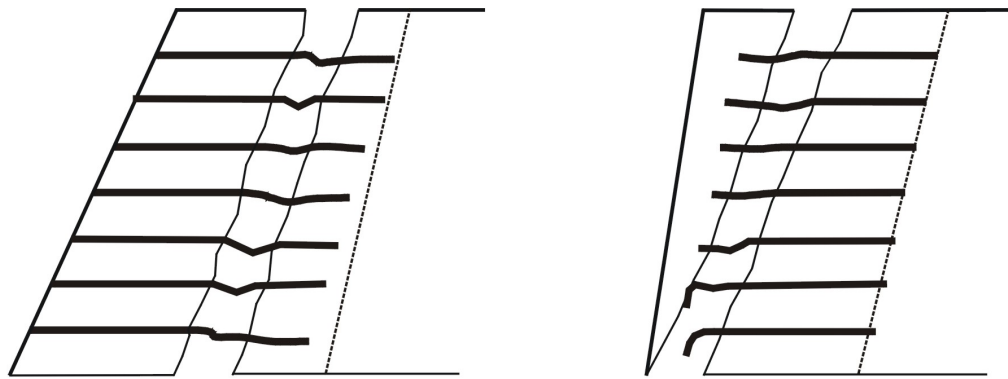


(c) Movement Joint (with overlapping) abutting Reinforced Concrete Structure

**Figure 53 – Typical Joint Details of Reinforced Fill Structures**

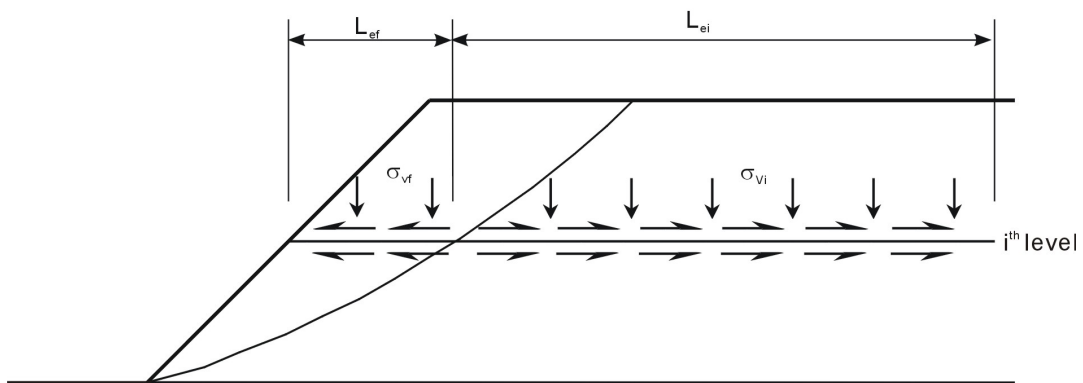


**Figure 54 – Design Procedure for Reinforced Fill Slopes**



(a) Pullout of Reinforcement from the Resisting Mass (Standard Pullout)

(b) Pullout of Reinforcement from the Yielding Fill Mass (Front Face Pullout)



Stability requirements :

Standard pullout  $2bL_{ei}\mu_{PD}\sigma'_{vi} > T_i$   
 Front face pullout  $2bL_{ef}\mu_{PD}\sigma'_{vf} > T_i$

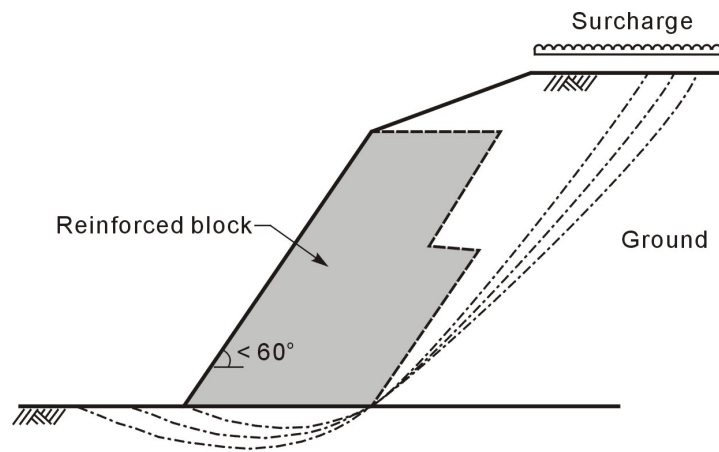
(c) Assessment of Pullout

Legend :

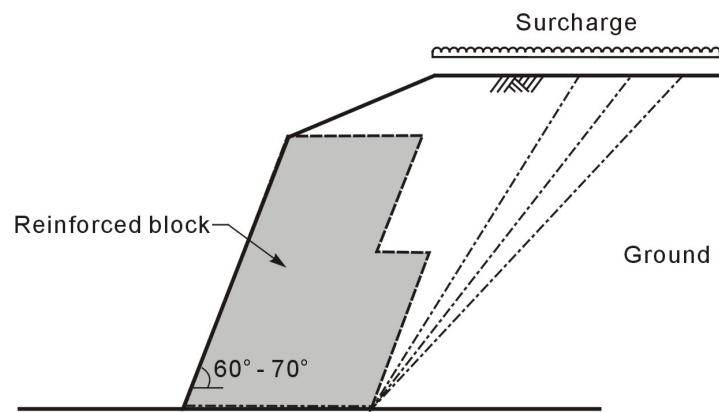
- $\mu_{PD}$  design coefficient of interaction against pullout
- $T_i$  design tension in the  $i^{th}$  level reinforcement
- $b$  width of reinforcement

**Figure 55 – Pullout of Reinforcement from the Reinforced Block**



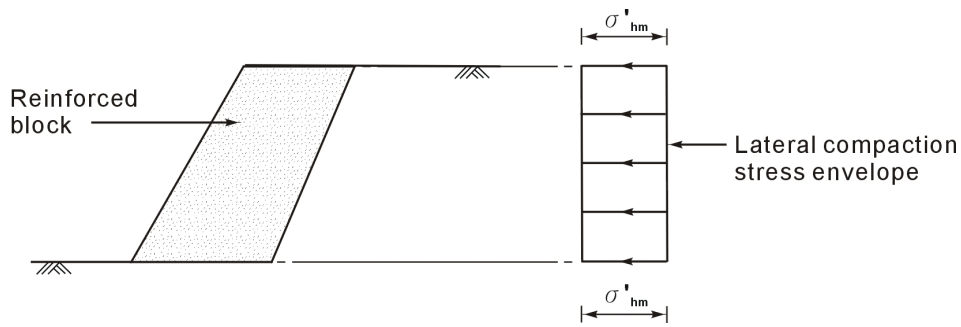


(a) Determination of Overall Slope Stability based on Curvilinear Failure Mechanism



(b) Determination of Overall Slope Stability based on Two-Part Wedge Failure Mechanism

**Figure 56 – Determination of Overall Slope Stability**



Design value of compaction induced stress  $\sigma'_{hm} = r\sqrt{\gamma_f Q\gamma}$

Where  $\gamma_f$  = partial factor as defined in Table 7  
 = 1.5 for ultimate limit state check

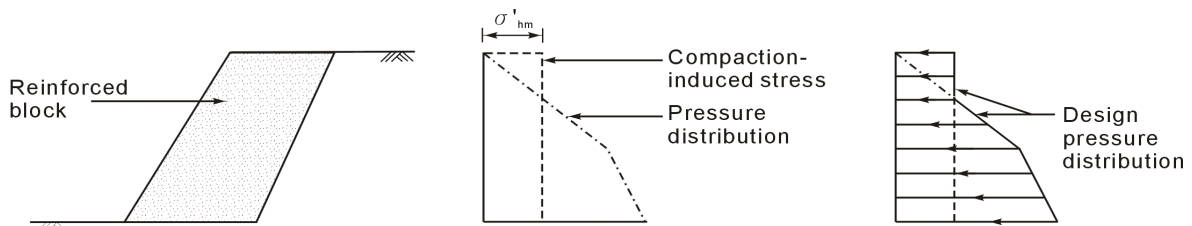
Q = intensity of effective line load induced by compaction plant<sup>(1)</sup>

$\gamma$  = fill unit weight

r = factor to account for relaxation of compaction stress, as given below:

Type of reinforcing element	Type of ultimate limit state	
	Tension failure, failure of connection and rupture of facing elements	All other modes
'extensible' ( $\epsilon_d^{(2)} \geq 1\%$ )	r = 0.45	r = 0
'inextensible' ( $\epsilon_d^{(2)} < 1\%$ )	r = 0.90	r = 0

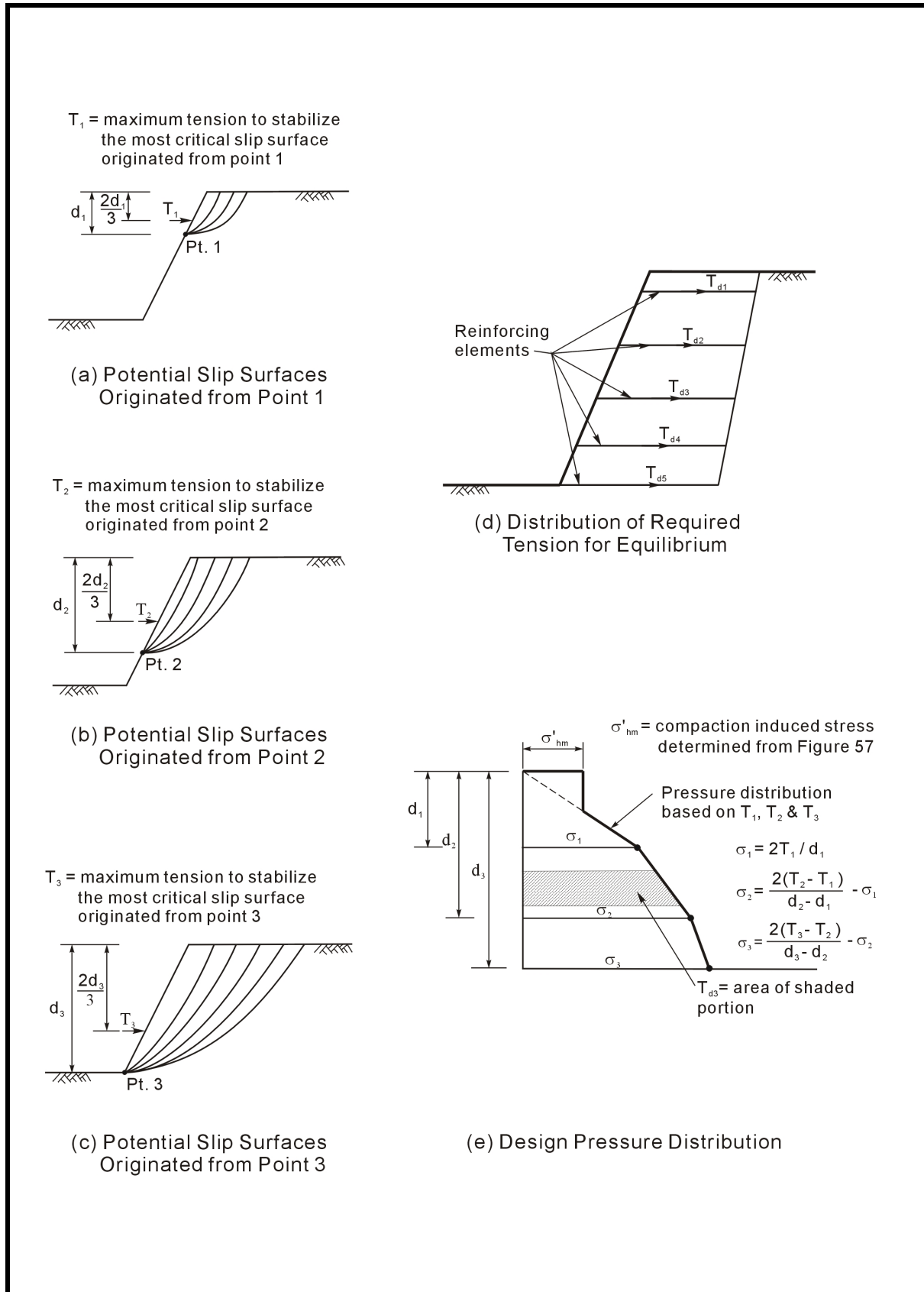
(a) Lateral Earth Pressure Induced by Compaction



(b) Design Pressure Distribution Including Effects of Compaction-induced Stress

- Notes :
- (1) For dead weight rollers, the effective line load is the weight of the roller divided by its roll width, and for vibratory rollers it should be calculated using an equivalent weight of the roller plus the centrifugal force generated by the roller's vibrating mechanism. The latter may be taken to be equal to the dead weight of the roller in the absence of trade data.
  - (2)  $\epsilon_d$  is the strain of the reinforcing elements at working stress.
  - (3) The compaction-induced stress considered in the design should be clearly stated on the drawings.
  - (4) Reference should be made to Section 7.5.2 for assessment of short-term strain in reinforcement.

Figure 57 – Simplified Method of the Evaluation of Compaction-induced Stress



**Figure 58 – Determination of the Design Tension in Reinforcement by Rigorous Method of Limit Equilibrium Analysis**

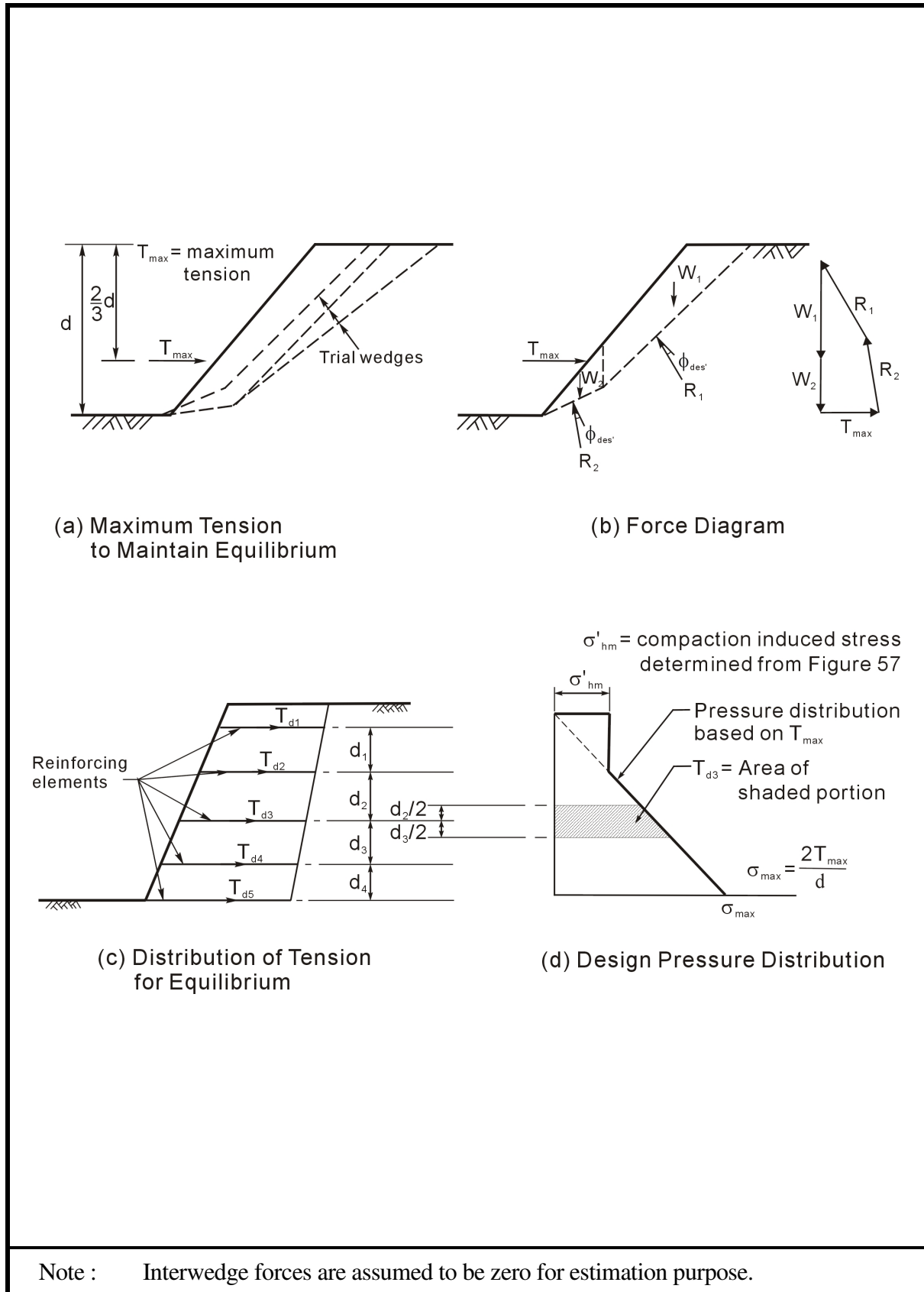


Figure 59 – Estimation of the Design Tension by Two-part Wedge Method

## Appendix A

### Model Specification for Reinforced Fill Structures and Slopes

## REINFORCED FILL STRUCTURES AND SLOPES

### GENERAL

<i>Earthwork</i>	A.01	Earthworks shall comply with Section 6 of the General Specification for Civil Engineering Works (1992) published by the Government of the Hong Kong Special Administrative Region unless as stated in this Specification.
<i>Testing: fill material</i>	A.02	Testing for fill material shall comply with Section 6 of the General Specification for Civil Engineering Works (1992) published by the Government of the Hong Kong Special Administrative Region unless as stated in this Specification.
<i>Granular filter</i>	A.03	Granular filter shall comply with Part 5, Section 7 of the General Specification for Civil Engineering Works (1992) published by the Government of the Hong Kong Special Administrative Region unless as stated in this Specification.
<i>Geotextile filter</i>	A.04	Geotextile filter shall comply with Part 5, Section 7 of the General Specification for Civil Engineering Works (1992) published by the Government of the Hong Kong Special Administrative Region unless as stated in this Specification.
<i>Concrete</i>	A.05	Concrete shall comply with Section 16 of the General Specification for Civil Engineering Works (1992) published by the Government of the Hong Kong Special Administrative Region unless as stated in this Specification.
<i>Joint filler and sealant</i>	A.06	Joint filler and joint sealant shall comply with Part 2, Section 16 of the General Specification for Civil Engineering Works (1992) published by the Government of the Hong Kong Special Administrative Region unless as stated in this Specification.

---

### GLOSSARY OF TERMS

<i>Reinforced fill structure</i>	A.07	Reinforced fill structure is a structure with a vertical or near-vertical facing that is within 20° from the vertical which comprises tensile reinforcing elements embedded in a compacted mass of fill and shall include any connections, facings and granular filter and drainage material which may be necessary to ensure its stability.
<i>Reinforced fill slope</i>	A.08	Reinforced fill slope is a feature with a face inclination of more than 20° from the vertical which comprises tensile reinforcing elements embedded in a compacted mass of fill and shall include any connections, facings and granular filter and drainage material which may be necessary to ensure its stability.

<i>Fill material</i>	A.09	Fill material is the material in the reinforced fill structure or slope in contact with the reinforcing elements, connections and facings, and shall include both the selected fill material and any granular filter and drainage material.
<i>Selected fill material</i>	A.10	Selected fill material is that part of the fill material in the reinforced fill structure or slope which is not primarily provided as a filter or for drainage.
<i>Reinforced fill product design data sheets</i>	A.11	Reinforced fill product design data sheets are issued by the Civil Engineering and Development Department of the Government of the Hong Kong Special Administrative Region which specifies design strengths of proprietary reinforcing products and their conditions of use in Hong Kong. <span style="float: right;">[Amd GG6/01/2022]</span>

---

## MATERIALS

<i>Facing units</i>	A.12	<p>(1) Facing shall be constructed in units to retain the fill using one or more of the following materials:</p> <ul style="list-style-type: none"> <li>(a) reinforced concrete conforming to BS EN 206: 2013 + A2: 2021, BS 8500-1: 2015 + A2: 2019 and BS 8500-2: 2015 + A2: 2019, <span style="float: right;">[Amd GG6/01/2017] [Amd GG6/01/2022]</span></li> <li>(b) carbon steel strips, sheets or mesh conforming to BS 1449: 1991, BS 4482: 2005, BS4483: 2005, BS EN 10025-1: 2004, BS EN 10025-2: 2019 or BS EN 10130: 2006. The fabricated components shall be hot-dip galvanized in accordance with Clause A.14, <span style="float: right;">[Amd GG6/01/2017] [Amd GG6/01/2022]</span></li> <li>(c) structural steel sections conforming to BS EN 10025-1: 2004 and BS EN 10025-2: 2019. The fabricated components shall be hot-dip galvanized in accordance with Clause A.14, <span style="float: right;">[Amd GG6/01/2017] [Amd GG6/01/2022]</span></li> <li>(d) segmental block units conforming to the requirements of the Contract,</li> <li>(e) proprietary product with reinforced fill product design data sheets, and <span style="float: right;">[Amd GG6/01/2022]</span></li> <li>(f) any other material as specified or approved by the Engineer.</li> </ul> <p>(2) Bearing pad for facing units shall be recommended by the facing unit manufacturer and approved by the Engineer.</p>
---------------------	------	---

**Reinforcing elements  
and connections**

A.13

(1) Reinforcing elements shall comprise one or more of the following: [Amd GG6/01/2022]

- (a) metallic reinforcing elements formed from carbon steel conforming to BS 1449 : 1991, BS 4482: 2005, BS 4483: 2005, BS EN 10025-1: 2004, BS EN 10025-2: 2019 or BS EN 10130: 2006. The fabricated components shall be hot-dip galvanized in accordance with Clause A.14, [Amd GG6/01/2017]  
[Amd GG6/01/2022]
- (b) proprietary polymeric reinforcing products covered by reinforced fill product design data sheets issued by the Civil Engineering and Development Department, Government of the Hong Kong Special Administrative Region, and [Amd GG6/01/2022]
- (c) any other materials as specified or approved by the Engineer.

(2) Connections shall comprise one or more of the following:

- (a) precision hexagon bolts, screws and nuts conforming to BS 3692: 2014, [Amd GG6/01/2022]
- (b) black hexagon bolts, screws and nuts conforming to BS 4190: 2014, [Amd GG6/01/2022]
- (c) plain washers conforming to BS 4320: 1968,
- (d) dowels and rods which shall be made from either steel bar conforming to CS2:2012 or steel conforming to BS 4482: 2005, BS EN 10025-1: 2004 or BS EN 10025-2: 2019, [Amd GG6/01/2017]  
[Amd GG6/01/2022]
- (e) tie strips which shall be made from carbon steel strip conforming to BS 1449: Part 1: 1991, BS 4482: 2005, BS EN 10025-1: 2004, BS EN 10025-2: 2019, or BS EN 10130: 2006, [Amd GG6/01/2017]  
[Amd GG6/01/2022]
- (f) proprietary connections covered by reinforced fill product design data sheets applicable to the polymeric reinforcing elements to be used, and [Amd GG6/01/2022]
- (g) any other material as specified or approved by the Engineer.

(3) Metallic connections between facings, between facings and reinforcing elements, and between reinforcing elements shall be electrolytically compatible such that corrosion will not be promoted through the use of dissimilar metals.



(4) Where components for connections are made from steel, these components shall be hot-dip galvanized in accordance with Clause A.14.

**Hot-dip galvanizing** A.14 Hot-dip galvanizing shall be to BS EN ISO 1461:2009, except that the minimum average zinc coating weight for the steel reinforcing elements specified in Clause A.13 shall be 610 g/m<sup>2</sup> (85 microns) for land-based structures or slopes and 1000 g/m<sup>2</sup> (140 microns) for structures or slopes that are periodically submerged in water.  
[Amd GG6/01/2017]

**Fill material** A.15 (1) Fill material shall consist of naturally occurring or processed material which at the time of deposition is capable of being compacted in accordance with the specified requirements to form a stable mass of fill.

(2) Fill material shall not contain any of the following:

- (a) material susceptible to volume change, including marine mud, swelling clays and collapsible soils,
- (b) peat, vegetation, timber, organic, soluble or perishable material,
- (c) dangerous or toxic material or material susceptible to combustion, and
- (d) metal, rubber, plastic or synthetic material.

(3) The grading and index properties of the selected fill shall be in accordance with the requirement specified in Table A.1.

(4) Selected fill for reinforced fill structures or slopes which contain hot-dip galvanized steel reinforcing elements shall comply with the electrical and chemical limits specified in Table A.2.

(5) Materials from excavation shall not be used as fill material for a reinforced fill structure or slope unless permitted by the Engineer.

(6) Fill material shall meet any additional requirements given in the Drawings or in the reinforced fill product design data sheets.  
[Amd GG6/01/2022]

**Granular filter** A.16 (1) Granular filter material for reinforced fill structures or slopes which contain hot-dip galvanized steel reinforcing elements shall comply with the electrical and chemical limits specified in Table A.2.

(2) Granular filter material shall meet any additional requirements given in the Drawings or in the reinforced fill product design data sheets.  
[Amd GG6/01/2022]

Table A.1 – Properties of Selected Fill Material

Requirement \ Material Type	Type I	Type II
Maximum Size (mm)	150	150
% Passing 10 mm BS Sieve Size	25 – 100	-
% Passing 600 microns BS Sieve Size	10 – 100	10 – 100
% Passing 63 microns BS Sieve Size	0 – 10	0 – 45
% Smaller than 2 microns	-	0 – 10
Coefficient of Uniformity	$\geq 5$	$\geq 5$
Liquid Limit (%)	Not applicable	$\leq 45$
Plasticity Index (%)	Not applicable	$\leq 20$
Notes: (1) No dispersant shall be used in the determination of particle size distribution. (2) BS Sieve Sizes are in accordance with BS ISO 3310-1: 2016.		
[Amd GG6/01/2017] [Amd GG6/01/2022]		

Table A.2 – Allowable Electrical and Chemical Limits of Selected Fill and Granular Filter

Fill Property	Allowable Limits	
	Submerged	Non-Submerged
pH	5 – 10	5 – 10
Resistivity (ohm m)	≥ 30	≥ 10
Organic Content	≤ 0.2	≤ 0.2
Redox Potential (volts) <sup>(3)</sup>	≥ 0.40 (Type I) ≥ 0.43 (Type II)	≥ 0.40 (Type I) ≥ 0.43 (Type II)
Microbial Activity Index <sup>(3)</sup>	≤ 5	≤ 5
Chloride Ion Content (% by weight)	≤ 0.01	≤ 0.02
Total Sulphate Content (% by weight)	≤ 0.10	≤ 0.20
Sulphate Ion Content (% by weight)	≤ 0.05	≤ 0.10
Total Sulphide Content (% by weight)	≤ 0.01	≤ 0.03
<p>Notes: (1) Submerged structure means a structure that is periodically submerged in water but excluding marine condition and contaminated or saline water.  (2) The measurement of organic content shall be carried out for clayey soils where more than 15% passes a 63 microns BS Sieve Size.  (3) The measurement of redox potential shall be carried out for clayey soils with an organic content in excess of the specified limit.  (4) BS Sieve Sizes are in accordance with BS ISO 3310-1: 2016.</p> <p style="text-align: right;">[Amd GG6/01/2017] [Amd GG6/01/2022]</p>		

## SUBMISSIONS

***Particulars of reinforced fill structure and slope***

A.17

(1) The Contractor shall submit to the Engineer a method statement for the construction of reinforced fill structures or slopes. The method statement shall contain proposals on:

- (a) details of Constructional Plant,
- (b) sequence of construction,
- (c) programme of work,
- (d) details of compaction methods including the thickness of compacted fill layers and capacities of the earthmoving and compaction equipment,
- (e) methods of supporting the facing units during construction,
- (f) details of all necessary temporary works for the construction of the reinforced fill structures or slopes,
- (g) names and records of experience of the Contractor's supervisory staff to be employed on the works,
- (h) arrangements for stockpiling fill material,
- (i) methods of controlling the moisture content of fill material,
- (j) methods of controlling surface water and groundwater,
- (k) methods of protecting earthworks and earthworks material from damage due to water and from weather conditions which may affect the earthworks or earthworks material,
- (l) methods of monitoring groundwater levels, and
- (m) methods of monitoring the ground and structures for movements.

(2) The particulars shall be submitted to the Engineer at least 6 weeks prior to the commencement of construction.

***Particulars of facing units***

A.18

(1) The following particulars of the proposed facing units shall be submitted to the Engineer:

- (a) manufacturer's literature on the proposed facing units, including the details of the associated bearing pad as appropriate,

- (b) method of construction, including details of corner and facing connections, and
- (c) a certificate showing the manufacturer's name, the date and place of manufacture and showing that the facing units and the associated bearing pads comply with the requirements stated in the Contract and including the results of tests specified in the certificate or as specified by the Engineer.

(2) The particulars, including certificates, shall be submitted to the Engineer at least 14 days before the first delivery of the material to the Site. Certificates shall be submitted for each batch of the material delivered to the Site and at least 14 days before the installation of the facing units starts.

***Particulars of reinforcing elements and connections***

- A.19 (1) The following particulars of the proposed reinforcing elements and connections shall be submitted to the Engineer:
- (a) manufacturer's literature on the proposed reinforcing element and connection,
  - (b) copies of valid quality assurance certificate such as ISO 9001 or equivalent certifying the quality system for the fabrication of the reinforcing elements and connections,
  - (c) for proprietary polymeric reinforcing elements and connections, copies of the reinforced fill product design data sheets, and [Amd GG6/01/2022]
  - (d) a certificate showing the manufacturer's name, the date and place of manufacture and showing that the reinforcing element and connection comply with the requirements stated in the Contract and including the results of tests specified in the certificate or as specified by the Engineer.

(2) The particulars, including certificates, shall be submitted to the Engineer at least 14 days before the first delivery of the material to the Site. Certificates shall be submitted for each batch of the material delivered to the Site and at least 14 days before the placement of the reinforcing element and connection starts.

(3) Sample of the reinforcing elements and connections shall be submitted to the Engineer at the same time as particulars of the material are submitted.

***Particulars of hot-dip galvanizing***

- A.20 (1) The following particulars of the proposed galvanized coatings to reinforcing elements and associated connection elements shall be submitted to the Engineer:
- (a) name and location of the galvanizing factory,

- (b) copies of valid quality assurance certificate such as ISO 9001 or equivalent certifying the quality system for the galvanization of the reinforcing elements and connections, and
- (c) a certificate from the manufacturer showing the date and place of application of the zinc coating and showing that the galvanization conforming to the requirements stated in the Contract and including the results of tests for weight/thickness and uniformity of galvanized coating.

(2) The particulars shall be submitted to the Engineer for each batch of galvanized reinforcing element delivered to the Site and at least 14 days before placing of the reinforcing element in the structure or slope starts.

(3) Samples of the galvanized reinforcing elements and connections shall be submitted to the Engineer at the same time as particulars of the material are submitted.

***Particulars of fill material***

A.21

(1) The following particulars of the proposed fill material shall be submitted to the Engineer for approval:

- (a) a statement identifying each source of supply and showing that sufficient suitable material is available for the works,
- (b) for material from borrow areas, a plan showing the location and extent of each proposed borrow area, and the location, depth and test results for each sample obtained and each in situ test carried out, and
- (c) certificates from a laboratory approved by the Engineer which show that each material proposed for use complies with the requirements of the Contract and has been tested in accordance with the appropriate test methods given in this Specification.

(2) On receipt of the above particulars, the Engineer may require the Contractor to carry out additional sampling and testing to demonstrate that the properties of the proposed sources of fill will meet the requirements of the Contract.

(3) The particulars, including certificates, shall be submitted to the Engineer at least 14 days before the first delivery of each material to the Site.

---

## HANDLING, DELIVERY AND STORAGE OF MATERIALS

- |   |      |  |
|---|------|--|
| <i>Handling and storage of facing units</i>         | A.22 | Facing units shall be stored and handled in such a manner as to eliminate the possibility of any damage. They shall be stored flat and supported on firm blocking. The use of porous blocks to stack facing units shall be avoided.  |
| <i>Handling and storage of reinforcing elements</i> | A.23 | <p>(1) Reinforcing elements shall not be subjected to rough handling, shock loading or dropping from a height.</p> <p>(2) Reinforcing elements shall be stored in such a manner to eliminate the possibility of any damage and shall be clearly labeled to identify items with different dimensions and properties.</p> <p>(3) Nylon, rope or padded slings shall be used for lifting galvanized reinforcing elements; bundles of reinforcement shall be lifted with a strongback or with multiple supports to prevent abrasion or excessive bending.</p> <p>(4) Polymeric reinforcing elements shall be properly stored and protected from precipitation, extend ultraviolet radiation, direct sunlight, chemicals that are strong acids or strong bases, flames including welding sparks, temperature in excess of 50°C, and any other environmental condition that may damage the physical property values.</p> |
| <i>Handling and storage of fill material</i>        | A.24 | <p>(1) Fill material shall not be handled or stored in a manner which will result in segregation, deterioration, erosion or instability of the material.</p> <p>(2) Different types of fill material shall be kept separate from each other. Fill material shall not be contaminated and shall be maintained in a suitable condition for deposition and compaction.</p>  |
- 

## FOUNDATION PREPARATION

- |                               |      |  |
|-------------------------------|------|--|
| <i>Foundation preparation</i> | A.25 | <p>(1) Unless otherwise specified by the Engineer, all existing vegetation and all unsuitable foundation material shall be removed in those areas where the reinforcing element is to be placed.</p> <p>(2) Surfaces on which reinforcing elements are to be placed shall be uniform, smooth and free of abrupt changes in slope, debris and irregularities that could damage the reinforcing elements.</p> <p>(3) During periods of heavy rainfall, the Contractor shall be responsible for protecting exposed surfaces of the foundation and the associated temporary cut slopes with heavy-duty impermeable sheeting.</p> |
|-------------------------------|------|--|

(4) Surface water flowing over exposed surfaces of the foundation and the temporary cut slopes shall be intercepted and diverted away to a safe discharge point. All drainage works shall be kept clear of debris to avoid blockage. Temporary conduits shall be provided to discharge water safely from partially completed surface drainage works.

(5) During excavation for the foundation of a reinforced fill structure or slope, a method of working shall be adopted in which the minimum of bare soil is exposed at any time. The method of working shall be agreed with the Engineer before the commencement of work.

(6) The Contractor shall remove all the soil and rock spoil spilled onto any sloping terrain during excavation for the foundation of a reinforced fill structure or slope prior to the commencement of the filling works.

## ERECTION OF FACING

### *Erection of elemental facing* A.26

(1) Elemental facing units shall be placed in successive courses unless otherwise specified. The spacing, level and alignment of each unit shall be checked immediately after its placement and again at the completion of each course.

(2) Adequate support of the facing units shall be provided at each stage of erection. The bottom course of facing units shall be shored to prevent movement during the deposition and compaction of fill material.

(3) As placed, all elemental facing units except those at the bottom course shall be inclined towards the fill to compensate for outward movement expected during or subsequent to compaction of the fill material. The degree of inclination shall be adjusted where necessary as deposition and compaction of fill material proceeds to ensure that the tolerances specified in Clause A.35 are met.

### *Erection of full height facing* A.27

(1) Full height facings shall be properly placed and propped during construction. The level and alignment of each facing shall be checked immediately after its placement and again at the completion of filling. The foundation for the props shall be adequate to support the propping loads.

(2) The degree of inclination of the full height facing shall be adjusted, and the stage when the props are removed shall be defined to ensure that the tolerances specified in Clause A.35 are met.

### *Erection of segmental block facing* A.28

(1) Segmental block units shall be placed to ensure that all units are in proper contact. The level and alignment of the block shall be checked immediately after its placement and again at the completion of each course.



- (2) The top of each course of segmental blocks installed shall be cleaned before the next course of segmental blocks are placed.
  - (3) Maximum stacked vertical height of segmental block units, prior to backfill deposition and compaction, shall not exceed two courses unless otherwise approved by the Engineer.
- 

## **PLACEMENT OF REINFORCING ELEMENTS**

### ***Placement and connection of reinforcing elements***

- A.29
- (1) The reinforcing elements shall be placed on the compacted fill material and connected to the facing units in accordance with the Drawings. They shall be placed at right angles to the facing units or the plan face of the slope, unless otherwise shown in the drawings. Bends in steel reinforcing elements shall be to a minimum radius of 300 mm.
  - (2) For reinforced fill slopes, in which the overfill and cut back technique is proposed to ensure proper compaction of the slope face, the construction method shall ensure that the reinforcing elements are exposed on the final slope face.
  - (3) Polymeric reinforcing elements shall be pulled tight to eliminate waves and wrinkles and secured in place as necessary by staples, pins, sand bags, backfill or as directed by the Engineer after placement.
  - (4) After a layer of polymeric reinforcing element has been placed, the next succeeding layer of fill material shall be placed and compacted as soon as practicable to avoid potential damage or extended exposure to direct sunlight. No polymeric reinforcing elements shall be left exposed for more than 8 hours after placement unless approved by the Engineer.
  - (5) Unless otherwise specified in the Drawings or as approved by the Engineer, no splices or seams shall be made in the primary direction of tensile strength in the polymeric reinforcing elements. When splices are approved, they shall be made for the full width of the polymeric reinforcing elements by using a similar material with similar strength. Splices shall not be placed within 1.5 m of the facing unit or slope face, within 1.5 m below top of structure or slope, nor within 1.5 m horizontally adjacent to another splice.

(6) Unless otherwise specified, adjacent rolls of polymeric reinforcing elements in reinforced fill slopes shall be butted together to maintain 100% horizontal coverage. When used in a wrap-around facing system, adjacent rolls of polymeric reinforcing elements shall be overlapped with a minimum width of 150 mm.

(7) Reinforcing elements at corners and radii shall be placed in accordance with the Drawings.

(8) No cut or hole should be made in polymeric reinforcing elements unless otherwise specified or approved by the Engineer.

---

## DEPOSITION AND COMPACTION OF FILL MATERIAL

### *Deposition and compaction of fill material*

A.30

(1) Fill shall be deposited and compacted in near-horizontal layers of the thicknesses required to achieve the specified end product and shall, as far as practicable, be brought up at a uniform rate so that all parts of the Site reach finished (formation) level at the same time.

(2) The fill material beyond 1.5 m of the back face of the structure or slope may be raised in thicker layers than that within the 1.5 m zone provided that this is compatible with the arrangement of the reinforcing elements and the difference in compacted levels does not exceed 300 mm.

(3) The fill material shall be deposited, spread, levelled and compacted in layers of thickness appropriate to the compaction methods to be used and so that each reinforcing element can be fixed at the required level on top of the compacted fill material without any voids forming directly underneath the reinforcing element. Unless otherwise permitted by the Engineer, layers of fill material shall be horizontal, except for any gradient required for drainage, and the thickness of each layer shall be uniform over the area to be filled.

(4) The deposition and compaction of fill material shall be carried out in a direction parallel to the face of the structure or slope and shall be completed in stages to follow closely the erection of facing units and the deposition of reinforcing elements.

(5) The fill material shall be compacted as soon as practicable after being deposited and in a manner appropriate to the location and to the material to be compacted. The in situ dry density of the compacted fill material shall be at least 95% of the maximum dry density. Compaction shall continue until the whole layer of fill material has attained the minimum in situ dry density specified above.

(6) Cobbles, boulders, rock or waste fragments whose largest dimension is greater than two-thirds of the loose layer thickness shall not be incorporated into the fill.

(7) The Contractor shall ensure that the reinforcing elements and facing units are not damaged or displaced during deposition and compaction. Tracked machines or vehicles shall not be operated on top of reinforcing elements which are not covered by at least 150 mm of fill material.

(8) No fill shall be deposited and left uncompacted at the end of a working day. The surface of compacted fill platform shall be graded to ensure free runoff of rainwater without ponding.

**Moisture content of fill material** A.31

(1) The fill material shall be at optimum moisture content during compaction. The tolerance on the optimum moisture content shall be  $\pm 3\%$  provided that the fill material is capable of being compacted in accordance with the specified requirement to form a stable mass of fill. All necessary measures shall be taken to achieve and maintain the specified moisture content. The moisture content of the compacted surfaces shall be controlled to prevent cracking due to drying.

(2) The Contractor shall take all necessary steps to ensure that the fill is deposited at the moisture content necessary to achieve the specified level of compaction and shall, where necessary, add water to or dry the fill, in order to obtain this value. Where it is necessary to add water, this shall be done as a fine spray and in such a way that there is time for the water to be absorbed into the fill before being rolled by the plant.

(3) The Contractor shall examine the deposited fill and remove any deteriorated material prior to recommencement of filling.

**Compaction plant** A.32

(1) All vehicles and all construction equipment weighing more than 1000 kg shall be kept at least 1.5 m away from the face of the structure or slope.

(2) Compaction plant and compaction method shall be selected having regard to the proximity of existing trenches, excavations, retaining walls or other structures and all work shall be performed in such a way as to ensure that their existing stability is not impaired. In particular great care should be taken to limit the compactive effort close to reinforced fill facing panels to prevent damage to connections or produce displacement of the facing.

(3) Unless otherwise permitted by the Engineer, the fill material within 1.5 m of the face of reinforced fill structures or slopes supported by facings shall be compacted using:

- (a) vibro tamper,

- (b) vibrating plate compactor having a mass not exceeding 1000 kg, or
- (c) vibrating roller having a mass per metre width of not more than 1300 kg and a total mass of not more than 1000 kg.

(4) In the case of reinforced fill slopes compaction plant should be restricted to that which does not cause distortion and settlement of the edge of the slope. No sheepsfoot, grid rollers or other type of equipment employing a foot shall be used.

***Compaction adjacent to structures*** A.33

During construction, the fill material retained at the rear of the reinforced fill block, defined as the position coinciding with the ends of the reinforcing elements furthest away from the facing units, shall be maintained at the same level as the adjoining structure. Where the retained material is an existing earthwork or natural slope which requires temporary support by shoring, the shoring shall be removed progressively as the selected fill or filter material is compacted. The shoring shall be removed in such a manner to ensure that the stability of the adjacent ground is maintained, the compacted fill material is not disturbed and the formation of voids is prevented.

## DAMAGE TO COMPONENTS

***Damage to components*** A.34

(1) In the event of any facing units, reinforcing elements, joint filler or sealant sustaining damage during erection or installation, it shall be set aside until it has been inspected by the Engineer, who shall decide whether the Contractor can use it and if so under what conditions.

(2) Where approved by the Engineer, damaged galvanized coating of the reinforcing element or connection shall be repaired by applying at least two coats of metallic zinc-rich priming paint. Before receiving paint, the damaged area shall be cleaned and prepared in accordance with the paint manufacturer's instructions. The zinc coating thickness shall be greater than the specified thickness of the galvanized layer. [Amd GG6/01/2022]

(3) The cost of any repair and the cost of replacing rejected components shall be borne entirely by the Contractor.

## TOLERANCES

***Tolerances***

A.35

(1) Reinforced fill structures constructed using elemental facing units, full height facings, cast-in-place facings and segmental facing shall be within the tolerances stated in Table A.3 for the specified lines and levels.

- (2) The location of reinforcing elements shall be within  $\pm 50$  mm of the specified lines and levels.

Table A.3 – Tolerances of Reinforced Fill Structure

Description	Tolerance
Location of place of structure	$\pm 50$ mm
Overall height	$\pm 50$ mm
Bulging (vertical) and bowing (horizontal)	$\pm 20$ mm over 4.5 m straight edge
Steps in joints	$\pm 10$ mm
Crest alignment	$\pm 15$ mm from reference
Verticality	$\pm 5$ mm per metre

### TESTING: REINFORCING ELEMENTS – GENERAL REQUIREMENTS

- Batch: reinforcing elements** A.36 A batch of reinforcing elements or reinforcement connections is any quantity of reinforcing elements or reinforcement connections of the same type, size and grade, manufactured by the same plant, covered by the same testing certificates and delivered to the Site at any one time.
- Samples: reinforcing elements** A.37
- (1) Samples of reinforcing elements or reinforcement connections shall be provided from each batch of the material. Samples shall be delivered to the Site at least 14 days before installation of the reinforcing elements or reinforcement connections starts.
- (2) For metallic reinforcing elements, either 2 samples from each batch of the reinforcing element or samples taken at the rate of 1 sample per 100 m<sup>2</sup> of area of facing shall be provided for tests specified in Clause A.38(1), whichever is the larger.
- (3) For polymeric reinforcing element, either 2 samples from each batch of reinforcing element or samples taken at the rate of 1 sample per 100 m<sup>2</sup> of area of facing shall be provided for tests specified in Clause A.38(2), whichever is the larger.
- (4) For polymeric reinforcing element with carbon black as UV stabilizer, either 1 sample from each batch of reinforcing element or samples taken at the rate of 1 sample per 1,000 m<sup>2</sup> of area of facing shall be provided for tests specified in Clause A.38(3), whichever is the larger.

(5) For reinforcement connections, either 2 samples from each batch of the reinforcement connections or samples taken at the rate of 1 sample per 500 m<sup>2</sup> of area of facing shall be provided for testing, whichever is the larger.

(6) For multiple walls or slopes of the same reinforced fill system, the sampling specified in this Clause shall be based on the cumulative surface area of the facing of that reinforced fill system in the Contract.

(7) The number and size of specimen provided in each sample shall be sufficient for the specified testing and approved by the Engineer. Each specimen of reinforcing elements shall be taken from different strips, grids, sheets or meshes in the batch.

***Testing: reinforcing elements***

A.38

(1) Each sample of metallic reinforcing element taken as stated in Clause A.37(2) shall be tested to determine the following:

- (a) tensile strength, in accordance with Clause A.40(1), and
- (b) weight/thickness and uniformity of galvanized coating, in accordance with Clause A.42.

(2) Each sample of polymeric reinforcing element taken as stated in Clause A.37(3) shall be tested to determine the tensile strength in accordance with Clause A.40(2).

(3) Each sample of polymeric reinforcing element taken as stated in Clause A.37(4) shall be tested to determine the following:

- (a) carbon black content, in accordance Clause A.43, and
- (b) dispersal of carbon black content, in accordance with Clause A.45.

(4) Each sample of reinforcement connections taken as stated in Clause A.37(5) shall be tested to determine the tensile strength in accordance with Clause A.40.

***Non-compliance: reinforcing element***

A.39

(1) If the result of any test of a reinforcing element or reinforcement connection does not comply with the specified requirements for the property, additional samples shall be provided from the same batch and additional tests for the property shall be carried out. The number of additional samples shall be in accordance with Clause A.37.

(2) The batch shall be considered as not complying with the specified requirements for the property if the result of any additional test does not comply with the specified requirements for the property.

---

## TESTING: REINFORCING ELEMENT – TENSILE TEST

<i>Testing: tensile test</i>	A.40	<p>(1) The tensile strength of metallic reinforcing element and reinforcement connection shall be determined in accordance with BS EN ISO 6892-1: 2019 or other test method as approved by the Engineer. <span style="float: right;">[Amd GG6/01/2017] [Amd GG6/01/2022]</span></p> <p>(2) The tensile strength of polymeric reinforcing element shall be determined in accordance with BS EN ISO 10319:2015. The tensile strength of polymeric reinforcement connection shall be determined in accordance with BS EN ISO 10321:2008. <span style="float: right;">[Amd GG6/01/2017] [Amd GG6/01/2022]</span></p>
<i>Compliance criteria: reinforcement connection</i>	A.41	<p>The results of tensile tests on specimens of reinforcement connection shall comply with the following requirements:</p> <ul style="list-style-type: none"> <li>(a) the tensile strength shall not be less than the value specified in the manufacturer certification or as specified by the Engineer, and <span style="float: right;">[Amd GG6/01/2022]</span></li> <li>(b) the slip between the reinforcement connection and the parent reinforcing elements shall not exceed the limit as specified in the manufacturer certification or as specified by the Engineer.</li> </ul>

## TESTING: REINFORCING ELEMENT – WEIGHT /THICKNESS AND UNIFORMITY OF GALVANIZED COATING

<i>Testing: weight/thickness and uniformity of galvanized coating</i>	A.42	<p>The weight/thickness and uniformity of galvanized coating shall be determined in accordance with BS EN ISO 1461:2009. <span style="float: right;">[Amd GG6/01/2017]</span></p>
---	------	---

## TESTING: REINFORCING ELEMENT – CARBON BLACK CONTENT

<i>Testing: carbon black content</i>	A.43	<p>The carbon black content of polymeric reinforcing element shall be determined in accordance with BS 2782: Part 4 Method 452B (1993).</p>
<i>Compliance criteria: carbon black content</i>	A.44	<p>The carbon black content shall have a minimum concentration of 2% unless otherwise specified by the Engineer.</p>

### **TESTING: REINFORCING ELEMENT – DISPERSAL OF CARBON BLACK CONTENT**

<i>Testing: dispersal of carbon black content</i>	A.45	The dispersal of carbon black within polymeric reinforcing element shall be determined in accordance with ASTM D5596.
<i>Compliance criteria: dispersal of carbon black content</i>	A.46	The dispersal of carbon black content shall be in Category 1 in accordance with ASTM D5596 unless otherwise specified by the Engineer.

---

### **TESTING: FILL MATERIAL – GENERAL REQUIREMENTS**

<i>Batch: fill material</i>	A.47	A batch of fill material for reinforced fill structures or slopes is any quantity of fill material of the same type and which in the opinion of the Engineer has similar properties throughout. For the purpose of compaction tests in Clause A.49 or Clause A.50 a batch shall, in addition to the above, be fill material which is deposited in a single layer in any area of fill presented by the Contractor for testing on one occasion.
<i>Samples: fill material</i>	A.48	<p>(1) Tests in Clause A.49 or Clause A.50 except relative compaction test shall be carried out on each sample taken from each batch of fill material. At least 3 samples shall be taken from each batch of fill material and, where the volume of the batch exceeds 3,000 m<sup>3</sup>, 1 additional sample shall be taken for each additional 1,000 m<sup>3</sup> or part thereof.</p> <p>(2) Compaction tests in Clause A.49 or Clause A.50 shall be carried out on each sample taken from each batch of fill material or as required by the Engineer. At least 1 sample of granular filter and drainage material and 2 samples of selected fill material shall be taken from each batch of fill material and, where the plan area of the structure or slope exceeds 800 m<sup>2</sup>, 1 additional sample of granular filter and drainage material and 2 additional samples of selected fill material shall be taken for each additional 800 m<sup>2</sup> or part thereof.</p> <p>(3) Samples of fill material to be tested shall be delivered at the time as agreed by the Engineer.</p> <p>(4) Sampling and testing shall be carried out at positions specified by the Engineer.</p>
<i>Testing : fill material for reinforced fill structures or slopes with metallic components</i>	A.49	<p>Fill material for reinforced fill structures or slopes with metallic components shall be tested for the following as appropriate:</p> <ul style="list-style-type: none"> <li>(a) compaction tests, comprising the determination of maximum dry density, optimum moisture content, moisture content and relative compaction,</li> <li>(b) particle size distribution,</li> </ul>



- (c) liquid limit and plasticity index for fine fill material,
- (d) coefficient of uniformity,
- (e) pH,
- (f) resistivity,
- (g) organic content,
- (h) redox potential or microbial activity index,
- (i) chloride ion content,
- (j) total sulphate content,
- (k) sulphate ion content,
- (l) total sulphide content, and
- (m) any other test as specified in the reinforced fill product design data sheets or as required by the Engineer.

[Amd GG6/01/2022]

***Testing : fill material for reinforced fill structures or slopes without metallic components***

A.50

Fill material for reinforced fill structures or slopes without metallic components shall be tested for the following:

- (a) compaction tests, comprising the determination of maximum dry density, optimum moisture content, moisture content and relative compaction,
- (b) particle size distribution,
- (c) liquid limit and plasticity index for fine fill material,
- (d) coefficient of uniformity, and
- (e) any other test as specified in the reinforced fill product design data sheets or as required by the Engineer.

[Amd GG6/01/2022]

***Non-compliance: fill material***

A.51

If the result of any tests for fill material does not comply with the specified requirements for the property, additional samples shall be provided from the same batch and additional tests for the property shall be carried out. The number of additional samples shall be in accordance with Clause A.48 or as required by the Engineer.

---

**TESTING: FILL MATERIAL – RESISTIVITY**

*Testing: resistivity* A.52 The method of testing shall be in accordance with the method as stated in BS 1377-3: 2018 + A1: 2021, test 13.4. [Amd GG6/01/2022]

---

**TESTING: FILL MATERIAL – ORGANIC CONTENT**

*Testing: organic content* A.53 The method of testing shall be in accordance with the method as stated in Geospec 3, Clause 9. [Amd GG6/01/2017]

---

**TESTING: FILL MATERIAL – REDOX POTENTIAL**

*Testing: redox potential* A.54 The method of testing shall be in accordance with the method as stated in BS 1377-3: 2018 + A1: 2021, test 14. [Amd GG6/01/2022]

---

**TESTING: FILL MATERIAL – MICROBIAL ACTIVITY INDEX**

*Testing: microbial activity index* A.55 Not used. [Amd GG6/01/2017]

---

**TESTING: FILL MATERIAL – TOTAL SULPHIDE CONTENT**

*Testing: total sulphide content* A.56 Total sulphide content of the fill material shall be determined in accordance with APHA 18th edition, 1992, part 4500 B-F.

---

**TESTING: FILL MATERIAL – SHEAR STRENGTH**

*Testing: shear strength* A.57 The shear strength of the fill material shall be determined using triaxial apparatus or shear box apparatus in accordance with Geospec 3. For shear strength test using shear box apparatus, the test specimen shall be sheared under drained conditions under a normal stress equal to the theoretical maximum vertical earth pressure in the reinforced fill structures or slopes.

---

## **TESTING: FILL – REINFORCEMENT INTERACTION – GENERAL REQUIREMENTS**

<i>Samples: fill – reinforcement interaction</i>	A.58	<p>(1) Unless otherwise agreed by the Engineer, at least two samples of reinforcing elements for each reinforced fill system in the Contract as selected by the Engineer shall be tested for direct sliding resistance. Additional testing shall be carried out as requested by the Engineer to demonstrate the consistency of the test results or to verify design assumption due to material or fill variation. Samples for testing shall be delivered to the Site at least 14 days before installation of the reinforcing element in the structure or slope starts.</p> <p>(2) When direct sliding resistance test in accordance with Clause A.58(1) cannot be carried out or upon requested by the Engineer, samples of reinforcing element shall be tested for pullout resistance to verify design assumption due to fill or material variation. Samples for testing shall be delivered to the Site at least 14 days before installation of the reinforcing element in the structure or slope starts.</p>
<i>Testing: fill – reinforcement interaction</i>	A.59	<p>(1) Samples of reinforcing element shall be tested to determine the direct sliding resistance in accordance with Clause A.61 or other methods as approved by the Engineer.</p> <p>(2) Samples of reinforcing element shall be tested to determine the pullout resistance in accordance with Clause A.62 or other methods as approved by the Engineer.</p>
<i>Non-compliance: fill – reinforcement interaction</i>	A.60	<p>If the result of any tests for fill-reinforcement interaction does not comply with the specified requirements for the property, additional samples shall be provided from the same batch and additional tests for the property shall be carried out. The number of additional samples shall be in accordance with A.37.</p>

## **TESTING: COEFFICIENT OF FRICTION BETWEEN FILL MATERIAL AND REINFORCEMENT – DIRECT SLIDING**

<i>Testing: direct sliding</i>	A.61	<p>The coefficient of friction between the fill material and the reinforcing elements shall be determined by the direct shear test in accordance with Section 16.2 of Geospec 3, with the following modification:</p> <p>(a) The weight of fill material required to prepare a compacted test specimen 300 mm x 300 mm x 75 mm shall be calculated.</p> <p>(b) For strip reinforcing elements, the strips shall be cut to tightly fit the interior plan shape of the lower half of the</p>
--------------------------------	------	--

shear box. Ribbed strips shall be cut so that the ribs can be placed as far away from the edge of the box as possible. For plane strips, the top surface and for ribbed strips, the surface defined by the plane through the root of the ribs, shall be at least 1 mm and not more than 3 mm below the top edge of the lower half of the shear box. The reinforcing elements shall be aligned so that shearing can occur in a direction parallel to their longitudinal axes. The strips shall then be placed and secured in the lower shear box by filling the lower shear box with plaster of Paris so that the strips remain fixed at all stages of the test.

- (c) For grid, sheet or mesh reinforcing elements, the fill material shall be compacted into the lower shear box in accordance with Clause 16.2.5 of Geospec 3, except that the surface of the second compacted layer shall be between 1 mm and 2 mm below the top edge of the lower shear box. The grid, sheet or mesh shall then be cut and fitted to match the width of the shear box and to allow it to be secured over the top edge of the lower shear box. The reinforcing elements shall be aligned so that shearing can occur in a direction parallel to their longitudinal axes.
- (d) The fill material shall be deposited over the reinforcing element and compacted: in two equal layers until about 20 mm of the compacted fill projects above the top edge of the upper box, if vibratory compaction is used; or in two equal layers until the top of the compacted surface is approximately 20 mm below the top of the shear box, if static compaction is used.
- (e) Shearing shall be carried out until the horizontal displacement is twice the displacement recorded at peak shear stress or until any rib comes into contact with the edge of the shear box, whichever occurs first.
- (f) The result of the test shall be taken as the maximum ratio between the shear stress and the normal stress.

---

### **TESTING: COEFFICIENT OF FRICTION BETWEEN FILL MATERIAL AND REINFORCEMENT – PULLOUT**

*Testing: pullout*

A.62

The pullout resistance of reinforcing elements shall be determined in accordance with BS EN 13738: 2004 or other testing method as approved by the Engineer.

[Amd GG6/01/2022]

---

### **TESTING: FACING UNIT – REINFORCEMENT INTERACTION**

<i>Samples: facing unit – reinforcement interaction</i>	A.63	Upon requested by the Engineer, samples of reinforcing elements as selected by the Engineer shall be tested for facing unit – reinforcing element interaction to verify design assumption due to material variation. Samples for testing shall be delivered to the Site at least 14 days before installation of the reinforcing element in the structure or slope starts.
<i>Testing: facing unit – reinforcement interaction</i>	A.64	The method of testing shall be in accordance with NCMASRWU-1 or other test method as approved by the Engineer.
<i>Non-compliance: facing unit – reinforcement interaction</i>	A.65	If the result of any tests for facing unit-reinforcement interaction does not comply with the specified requirements for the property, additional samples shall be provided and additional tests for the property shall be carried out. The number of additional samples shall be determined by the Engineer.

---

### **TESTING: FACING UNITS INTERACTION**

<i>Samples: facing units interaction</i>	A.66	Upon requested by the Engineer, samples of segmental facing units as selected by the Engineer shall be tested for facing units interaction to verify design assumption due to material variation. Samples for testing shall be delivered to the Site at least 14 days before installation of the reinforcing element in the structure or slope starts.
<i>Testing: facing units interaction</i>	A.67	The method of testing shall be in accordance with NCMASRWU-2 or other test method as approved by the Engineer.
<i>Non-compliance: facing units interaction</i>	A.68	If the result of any tests for facing units interaction does not comply with the specified requirements for the property, additional samples shall be provided and additional tests for the property shall be carried out. The number of additional samples shall be determined by the Engineer.

---

Appendix B

Model Checklist for  
Reinforced Fill Construction Control

## Model Checklist for Reinforced Fill Construction Control

Activities		Compliance			Remarks
No.	Description	Yes	No	N/A	
<b>1</b>	<b>Pre-construction Review</b>				
1.1	Any approved drawings, geotechnical design reports and specifications?				
1.2	Any approved method statements providing construction procedures and sequences of works?				
1.3	Any material requirements, construction tolerances and acceptance/rejection criteria?				
1.4	Any compliance testing requirements to ensure the quality of the works?				
1.5	Any additional compliance testing requirement stipulated in the reinforced fill product design data sheets? <span style="color: red;">[Amd GG6/01/2022]</span>				
1.6	Any monitoring requirements to check the performance of the works?				
1.7	Any temporary works required to facilitate the construction of the permanent works?				
<b>2</b>	<b>Reinforcement and Facing Panel</b>				
2.1	Are the facing panels of correct shape, size?				
2.2	Are the reinforcement inserts on the facing panels correctly positioned?				
2.3	Are the reinforcement of correct type, grade, length and size?				
2.4	Are the metallic reinforcement being galvanized with the correct zinc coating weight/thickness?				
2.5	Are the polymeric reinforcement covered by valid reinforced fill product design data sheets? <span style="color: red;">[Amd GG6/01/2022]</span>				
2.6	Have the reinforcement and facing panels been inspected for damage?				
2.7	Are the reinforcement and facing panels being properly handled and stored?				
2.8	Have suitable samples of reinforcement (including connection) been taken for compliance testing?				
<b>3</b>	<b>Fill Material</b>				
3.1	Have suitable samples of fill material been taken for compliance testing?				
3.2	Do the grading and index properties of the fill material satisfy the requirements of the specification?				
3.3	Does the fill material comply with the electrical and chemical limits given in the specification?				

Activities		Compliance			Remarks
No.	Description	Yes	No	N/A	
<b>4</b>	<b>Preparation of Foundation</b>				
4.1	Has the foundation for the structure/slope been excavated to the required level?				
4.2	Has the foundation been protected from inclement weather?				
4.3	Are the levelling pads being set to the proper vertical and horizontal alignment?				
<b>5</b>	<b>Erection of Facing</b>				
5.1	Is the bottom course of the elemental facing units being shored up to prevent movement during fill deposition and compaction?				
5.2	Are full-height facing panels being properly placed and propped during construction?				
5.3	Does the stacked vertical height of segmental block units comply with the requirement of the specification?				
5.4	Have the alignment, level and tilt of the facing units been checked immediately after their placement and again at the completion of each course?				
5.5	Do the alignment, level, and tilt of the facing units meet the tolerances specified?				
5.6	Have the facing panels been damaged prior to or during installation?				
<b>6</b>	<b>Placement of Reinforcement</b>				
6.1	Have the reinforcement been laid in the correct orientation and level and properly connected to the facing units?				
6.2	Have the polymeric reinforcement been pulled tight to eliminate waves and wrinkles and secured in place?				
6.3	Have the polymeric reinforcement been left exposed to direct sunlight for more than 8 hrs after placement (If so, remedial action should be taken)?				
6.4	Have the adjacent rolls of polymeric reinforcement been butted together to maintain 100% horizontal coverage?				
6.5	Does the overlapping of adjacent rolls of polymeric reinforcement comply with the requirement specified for wrap-around facing?				
6.6	Do the splices or seams made in the polymeric reinforcement comply with the requirements specified?				



Activities		Compliance			Remarks
No.	Description	Yes	No	N/A	
<b>7</b>	<b>Deposition and Compaction of Fill Material</b>				
7.1	Do the compaction plants and compaction methods comply with the specification?				
7.2	Is the fill material being compacted in layers of thickness appropriate to the compaction methods?				
7.3	Has the degree of compaction been checked to comply with the specification?				
7.4	Does the moisture content of the placed fill material comply with the limits given in the specification?				
7.5	Have construction plants been kept off the reinforcement until a fill layer of 150mm thickness is deposited over the reinforcement?				
7.6	Has the surface of compacted fill platform been graded to ensure free runoff of rainwater without ponding at the end of a working day?				
<b>8</b>	<b>Temporary Drainage</b>				
8.1	Are adequate drainage channels being provided to divert the surface runoff away from the construction area?				
8.2	Has inspection of the proper functioning of the temporary drainage system been undertaken during and immediately after heavy rainfall?				

## Glossary of Symbols

## Glossary of Symbols

$\bar{a}_b$	Fraction of bearing surface area of reinforcement
$a_{des}$	Design ultimate adhesion at the unit-to-unit or unit-to-reinforcement interface
$a_e$	Width of the loading strip contact area parallel to the structure at the $i$ th level reinforcement
$a_o$	Width of the loading strip contact area parallel to the structure
$a_r$	Cross sectional area of reinforcement minus potential corrosion losses
$\bar{a}_s$	Fraction of planar surface area of reinforcement that is solid
$a_u$	Ultimate adhesion at the unit-to-unit or unit-to-reinforcement interface
$B_a$	Width of anchor head
$B_u$	Contact width at the interface of segmental block units
$b$	Width of reinforcement
$b_a$	Width of the longitudinal member of the grid reinforcement
$b_e$	Width of the loading strip contact area at right angles to the structure at the $i$ th level reinforcement
$b_i$	Width of the $i$ th level reinforcement
$b_o$	Width of the loading strip contact area at right angles to the structure
$C_u$	Coefficient of uniformity
$c'$	Cohesion of the soil under effective stress conditions
$D_m$	Embedment depth of reinforced walls and abutments
$d$	Distance of strip load from wall face (Figure 38)
$E$	Elastic modulus
$E_p$	Potential of platinum electrode
$E_r$	Redox potential
$e$	Eccentricity of an applied force
$e_b$	Eccentricity of the vertical resultant force acting on the base of reinforced fill structure

$e_i$	Eccentricity of the vertical resultant force acting on the $i$ th level reinforcement
$e'$	Eccentricity of the vertical resultant force acting on the $i$ th level reinforcement
$F_1$	Scale-effect factor for bearing ratio (Figure 20)
$F_2$	Shape-factor for bearing ratio (Figure 20)
$F_D$	Design value of loading $F$
$F_P$	Horizontal pad load (Figure 38 and Figure 39)
$G_D$	Design value of geotechnical parameters $G$
$G_u$	Distance from the centre of gravity of a segmental block unit measured from the front face
$H$	Height of reinforced fill structure
$H_e$	Effective wall height of reinforced fill structures (Figure 34)
$H_h$	Hinge height of segmental block wall (Figure 48)
$H_u$	Height of a segmental block unit
$h_a$	Thickness of reinforcement
$h_i$	Height of reinforced block above the $i$ th layer reinforcement
$K_a$	Coefficient of active earth pressure
$K_{des}$	Design coefficient of earth pressure
$K_o$	Coefficient of earth pressure at rest
$K_p$	Coefficient of passive earth pressure
$k$	Permeability of fill or drainage materials
$L$	Base width of reinforced fill structure
$L_a$	Length of anchor head
$L_e$	Embedment length of reinforcement (Figure 19(a))
$L_{ef}$	Length of that part of the $i$ th layer reinforcement in front of the failure plane
$L_{ei}$	Length of that part of the $i$ th layer reinforcement beyond the potential failure plane
$L_i$	Length of the $i$ th layer of reinforcing element

$m_w$	Mass of excavated soil in an insitu dry density test
$m_1$	Mass of water added to the resistivity cell in a resistivity test
$m_2$	Mass of water added to the end compartments of the resistivity cell in a resistivity test
$m_3$	Mass of soil specimen at its initial moisture content in a resistivity test
$N_i$	Normal load per unit length acting at the $i$ th level interface of facing units
$N_u$	Normal load per unit length acting at the interface of facing units
$n$	Number of effective layers of reinforcing elements
$P_a$	Resultant active force due to earth pressure
$P_{all}$	Allowable pullout resistance of anchor (Figure 21)
$P_{ds}$	Ultimate direct sliding resistance (Figure 19)
$P_L$	Vertical Pad Load (Figure 37 and Figure 39)
$P_n$	Effective normal force (Figure 15 & 19)
$P_p$	Ultimate pullout resistance (Figure 19)
$P_r$	Mobilised tensile force in reinforcement (Figure 15)
$P_s$	Disturbing shear force (Figure 15)
$P_{uds}$	Ultimate direct sliding resistance of reinforcement
$P_{up}$	Ultimate pullout resistance of reinforcement
pH	Value of acidity of an aqueous solution
$Q$	Intensity of effective line load induced by compaction plant
$q$	Uniformly distributed surcharge on top of a structure
$q_s$	Uniformly distributed surcharge on top of a structure due to dead load only
$q_{ult}$	Ultimate bearing capacity of a foundation soil
$R$	Reaction force acting on potential failure plane
$R_D$	Design value of reinforcement parameters $R$
$R_h$	Horizontal factored disturbing force
$R_v$	Vertical factored resultant force

$R_{vb}$	Vertical factored resultant force acting on the base of reinforced fill structure
$R_{vi}$	Vertical factored resultant force acting on the $i$ th level reinforcement
$r$	Factor to allow for relaxation of compaction stress
$S$	Spacing of the traverse member of the grid reinforcement
$S_b$	Spacing of the longitudinal member of the grid reinforcement
$S_h$	Horizontal spacing of reinforcement
$S_{hi}$	Horizontal spacing of the $i$ th layer of reinforcement
$S_t$	Spacing of the traverse member of the grid reinforcement
$S_v$	Vertical spacing of reinforcement
$S_{vi}$	Vertical spacing of the $i$ th layer of reinforcement
$s$	Front slope gradient (Figure 34)
$T$	Total tensile force to be resisted by the layers of reinforcement which anchor a wedge of reinforced soil, per metre 'run' (wedge analysis)
$T_{ci}$	Tensile force due to cohesion in the selected fill at the $i$ th level reinforcement
$T_D$	Design tensile strength per unit width of reinforcement
$T_{Di}$	Design tensile strength per unit width of the $i$ th layer reinforcement
$T_{ei}$	Tensile force due to self weight of fill plus any surcharge and overturning moment caused by earth pressure to be resisted by the $i$ th layer of reinforcing elements
$T_{fi}$	Tensile force due to the horizontal shear applied to the top of the structure to be resisted by the $i$ th layer of reinforcing elements (Figure 38)
$T_i$	Required tension of the $i$ th layer reinforcement
$T_{pDi}$	Design pullout resistance of the $i$ th layer reinforcement
$T_{pi}$	Tensile force due to the vertical loading applied to the top of the structure to be resisted by the $i$ th layer of reinforcing elements (Figure 37)
$T_{ult}$	Ultimate characteristic tensile strength per unit width of polymeric reinforcement
$t_a$	Width of the traverse member of the grid reinforcement
$t_c$	Construction period of reinforced fill structures or slopes
$t_d$	Design life

$U$	Uplift force due to water pressure
$U_i$	Uplift force due to water pressure acting on the $i$ th layer reinforcement
$V_i$	Maximum required shear force per unit length of wall at the $i$ th level interface of facing units
$V_{iD}$	Design shear capacity per unit length of wall acting at the $i$ th level interface of facing units
$V_u$	Ultimate shear capacity per unit length of wall acting at the interface of facing units
$W$	Total weight of soil structure per metre 'run'
$W_u$	Width of segmental block unit
$w_s$	Moisture content
$w_0$	Initial moisture content
$z_p$	A parameter for calculating $T_{fi}$
$\alpha$	Wall batter
$\alpha_{ds}$	Direct sliding coefficient
$\alpha_p$	Pullout coefficient
$\alpha_t$	Trajectory of tensile strain arc (Figure 17)
$\beta$	Backslope angle
$\beta_t$	Trajectory of compressive strain arc (Figure 17)
$\delta$	Interface friction angle between wall and fill
$\delta_b$	Angle of base shearing resistance
$\delta_s$	Skin friction angle for fill shearing over the reinforcement
$\epsilon_d$	Short term strain of the reinforcing elements loaded to the design tension
$\phi'$	Angle of shearing resistance of the fill under effective stress conditions
$\phi'_{des}$	Design angle of shearing resistance of the fill under effective stress conditions
$\phi'_p$	Peak angle of shearing resistance under effective stress conditions
$\gamma'$	Effective unit weight of the soil
$\gamma_{cd}$	Partial factor on reinforcement to allow for construction damage

$\gamma_{cr}$	Partial factor on reinforcement to allow for creep
$\gamma_d$	Partial factor on reinforcement to allow for durability
$\gamma_f$	Partial load factor
$\gamma_m$	Partial material factor
$\gamma_n$	Partial consequence factor
$\phi$	Inclination angle of potential failure wedge
$\lambda_{des}$	Design peak friction angle at the unit-to-unit or unit-to-reinforcement interface
$\lambda_u$	Peak friction angle at the unit-to-unit or unit-to-reinforcement interface
$\mu_{ds}$	Coefficient of friction against direct sliding
$\mu_{dsD}$	Design coefficient of friction against direct sliding
$\mu_p$	Coefficient of friction against pullout
$\mu_{pD}$	Design coefficient of friction against pullout
$\theta$	Inclination of reinforcement to vertical or failure plane
$\theta_u$	Angle of the steepest plane between any two layer of reinforcement (Figure 42)
$\sigma_t$	Minimum ultimate tensile strength of steel
$\sigma'_b$	Bearing stress acting on the traverse element of the reinforcement
$\sigma'_{hm}$	Compaction induced stress
$\sigma'_n$	Effective normal stress at the fill-reinforcement interface
$\sigma'_b/\sigma'_n$	Bearing stress ratio (Figure 20)
$\sigma'_{vb}$	Vertical effective stress acting at the base of reinforced fill structure
$\sigma'_{vf}$	Vertical effective stress (overburden stress) acting on reinforcement in front of a failure plane in a reinforced slope
$\sigma'_{vi}$	Vertical effective stress acting on the $i$ th level reinforcement
$\tau$	Shear stress
$\psi$	Angle of potential failure plane of Tieback Method



## Glossary of Terms

## Glossary of Terms

- Design load.** The load obtained by factoring the selected value by a partial load factor.
- Design strength.** The strength of material obtained by factoring the characteristic strength by a partial material factor.
- Design tension.** The tensile force developed in the reinforcement due to the design load acting on the reinforced fill structure or slope.
- Geogrid.** Polymeric, planar structure consisting of an open network of connected tensile elements used in geotechnical and civil engineering applications.
- Geotextile.** Permeable, polymeric material, which may be woven, nonwoven or knitted, used in geotechnical and civil engineering applications.
- Partial consequence factor.** The factor applied to the design value of a reinforcement parameter or a parameter relating to the interaction between facing units.
- Partial load factor.** The factor applied to the selected value of a loading.
- Partial material factor.** The factor applied to the selected value of a geotechnical parameter or a reinforcement parameter or a parameter relating to the interaction between facing units.
- Polymeric reinforcement.** The generic term that encompasses geosynthetic reinforcement materials used in geotechnical engineering.
- Proprietary products.** Manufactured proprietary materials used in reinforced fill structures or slopes including reinforcement, facings, connections and fasteners, filters and drains, joint fillers and sealants.
- Reinforced fill.** Compacted mass of fill with predominantly horizontal layered reinforcing elements to improve its tensile and shear strength capacities.
- Reinforced fill product design data sheet.** A document issued by the Civil Engineering and Development Department of the Hong Kong SAR Government, which specifies suitable design strengths of a specific proprietary reinforcement and the conditions of use for the Hong Kong conditions. [Amd GG6/01/2022]
- Reinforced fill slope.** A slope with a face inclination of more than 20° from the vertical which comprises tensile reinforcing elements embedded in a compacted mass of fill and shall include any connections, facings and granular filter and drainage material which may be necessary to ensure its stability.
- Reinforced fill structure.** A structures with a vertical or near-vertical facing that is within 20° from the vertical which comprises tensile reinforcing elements embedded in a compacted mass of fill and shall include any connections, facings and granular filter and drainage material which may be necessary to ensure its stability.

**Residual soil.** Soil derived from insitu rock weathering in which all trace of the original rock texture, fabric and structure has been destroyed.

**Saprolite.** Soil derived from insitu rock weathering in which evidence of the original rock texture, fabric and structure is retained.

**Serviceability limit state.** A state at which movements of the reinforced fill structure or slope affect the appearance or efficient use of the structure or slope or nearby structures or services which rely upon its support.

**Ultimate limit state.** A state at which a failure mechanism can form in the ground or within or through the reinforced fill structure or slope, or when movement of the reinforced fill structure or slope leads to severe damage to its structural elements or in nearby structures or services.

## GEO PUBLICATIONS AND ORDERING INFORMATION

### 土力工程處刊物及訂購資料

An up-to-date full list of GEO publications can be found at the CEDD Website <http://www.cedd.gov.hk> on the Internet under "Publications". The following GEO publications can also be downloaded from the CEDD Website:

- i. Manuals, Guides and Specifications
- ii. GEO technical guidance notes
- iii. GEO reports
- iv. Geotechnical area studies programme
- v. Geological survey memoirs
- vi. Geological survey sheet reports

**Copies of some GEO publications (except geological maps and other publications which are free of charge) can be purchased either by:**

#### Writing to

Publications Sales Unit,  
Information Services Department,  
Room 626, 6th Floor,  
North Point Government Offices,  
333 Java Road, North Point, Hong Kong.

#### or

- Calling the Publications Sales Section of Information Services Department (ISD) at (852) 2537 1910
- Visiting the online Government Bookstore at <http://www.bookstore.gov.hk>
- Downloading the order form from the ISD website at <http://www.isd.gov.hk> and submitting the order online or by fax to (852) 2523 7195
- Placing order with ISD by e-mail at [puborder@isd.gov.hk](mailto:puborder@isd.gov.hk)

**1:100 000, 1:20 000 and 1:5 000 geological maps can be purchased from:**

Map Publications Centre/HK,  
Survey & Mapping Office, Lands Department,  
23th Floor, North Point Government Offices,  
333 Java Road, North Point, Hong Kong.  
Tel: (852) 2231 3187  
Fax: (852) 2116 0774

**Any enquires on GEO publications should be directed to:**

Chief Geotechnical Engineer/Standards and Testing,  
Geotechnical Engineering Office,  
Civil Engineering and Development Department,  
Civil Engineering and Development Building,  
101 Princess Margaret Road,  
Homantin, Kowloon, Hong Kong.  
Tel: (852) 2762 5351  
Fax: (852) 2714 0275  
E-mail: [ivanli@cedd.gov.hk](mailto:ivanli@cedd.gov.hk)

詳盡及最新的土力工程處刊物目錄，已登載於土木工程拓展署的互聯網網頁<http://www.cedd.gov.hk> 的“刊物”版面之內。以下的土力工程處刊物亦可於該網頁下載：

- i. 指南、指引及規格
- ii. 土力工程處技術指引
- iii. 土力工程處報告
- iv. 岩土工程地區研究計劃
- v. 地質研究報告
- vi. 地質調查圖表報告

**讀者可採用以下方法購買部分土力工程處刊物(地質圖及免費刊物除外):**

#### 書面訂購

香港北角渣華道333號  
北角政府合署6樓626室  
政府新聞處  
刊物銷售組

#### 或

- 致電政府新聞處刊物銷售小組訂購 (電話：(852) 2537 1910)
- 進入網上「政府書店」選購，網址為 <http://www.bookstore.gov.hk>
- 透過政府新聞處的網站 (<http://www.isd.gov.hk>) 於網上遞交訂購表格，或將表格傳真至刊物銷售小組 (傳真：(852) 2523 7195)
- 以電郵方式訂購 (電郵地址：[puborder@isd.gov.hk](mailto:puborder@isd.gov.hk))

**讀者可於下列地點購買1:100 000、1:20 000及1:5 000地質圖：**

香港北角渣華道333號  
北角政府合署23樓  
地政總署測繪處  
電話: (852) 2231 3187  
傳真: (852) 2116 0774

**如對本處刊物有任何查詢，請致函：**

香港九龍何文田公主道101號  
土木工程拓展署大樓  
土木工程拓展署  
土力工程處  
標準及測試部總土力工程師  
電話: (852) 2762 5351  
傳真: (852) 2714 0275  
電子郵件: [ivanli@cedd.gov.hk](mailto:ivanli@cedd.gov.hk)

