

Figure 1 – Schematic View of Shore Profile

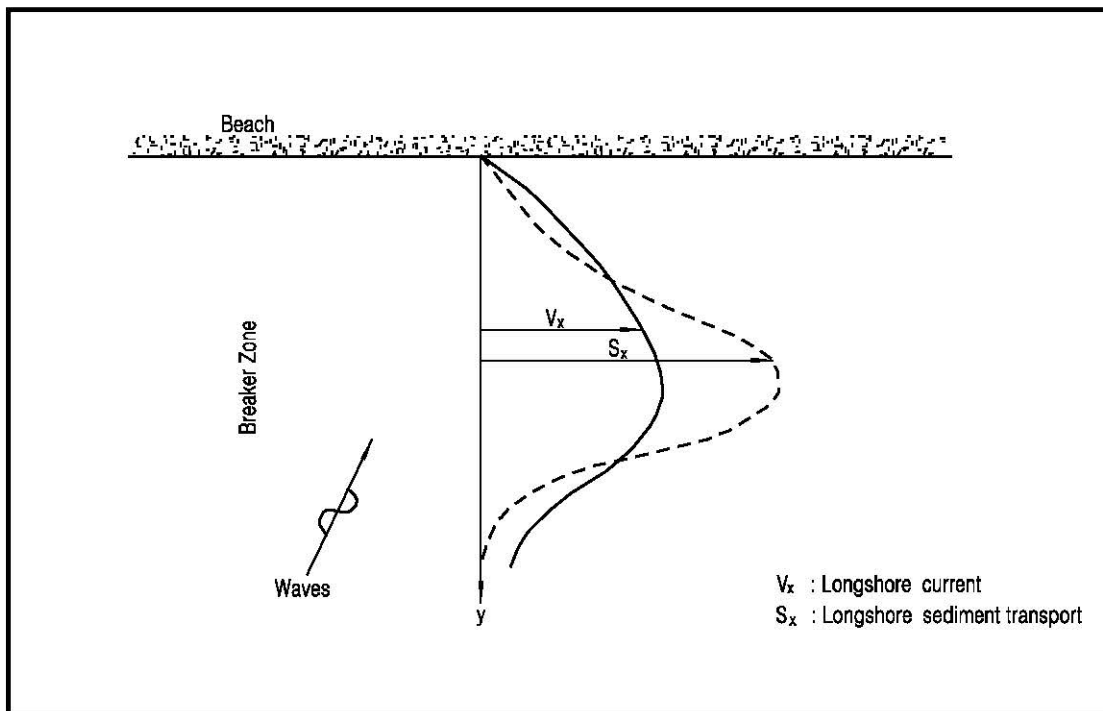

Figure 2 – Longshore Current and Longshore Sediment Transport

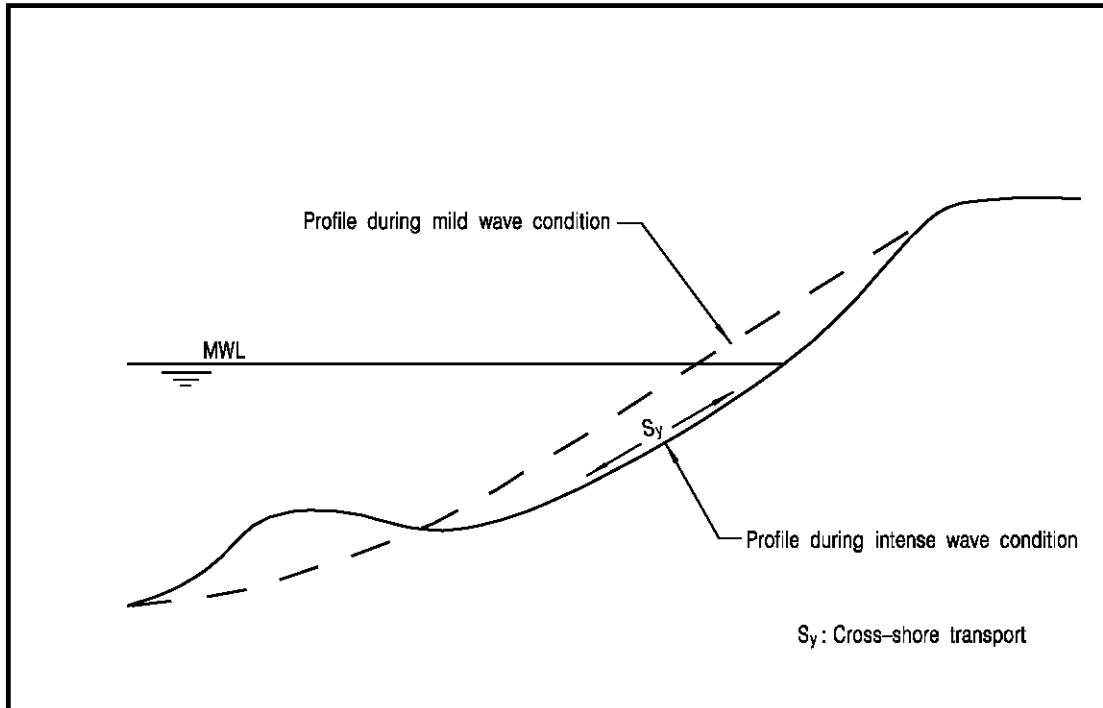

Figure 3 – Beach Profiles

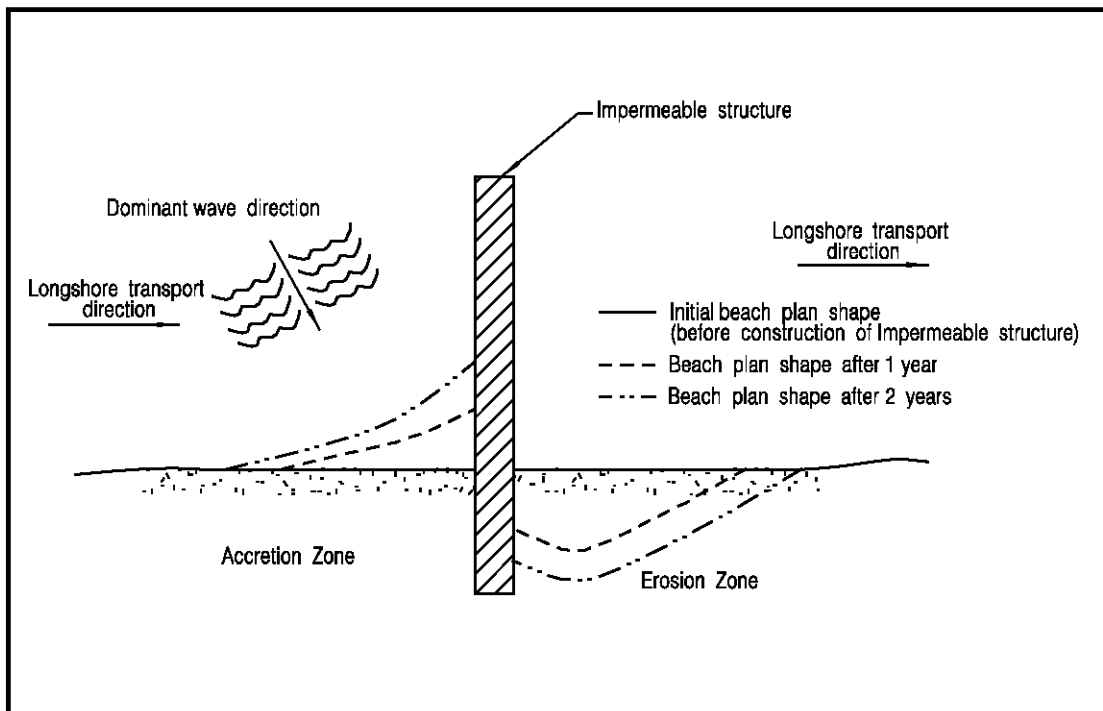

Figure 4 – Effect of Coastal Structure on Beach Plan Shape

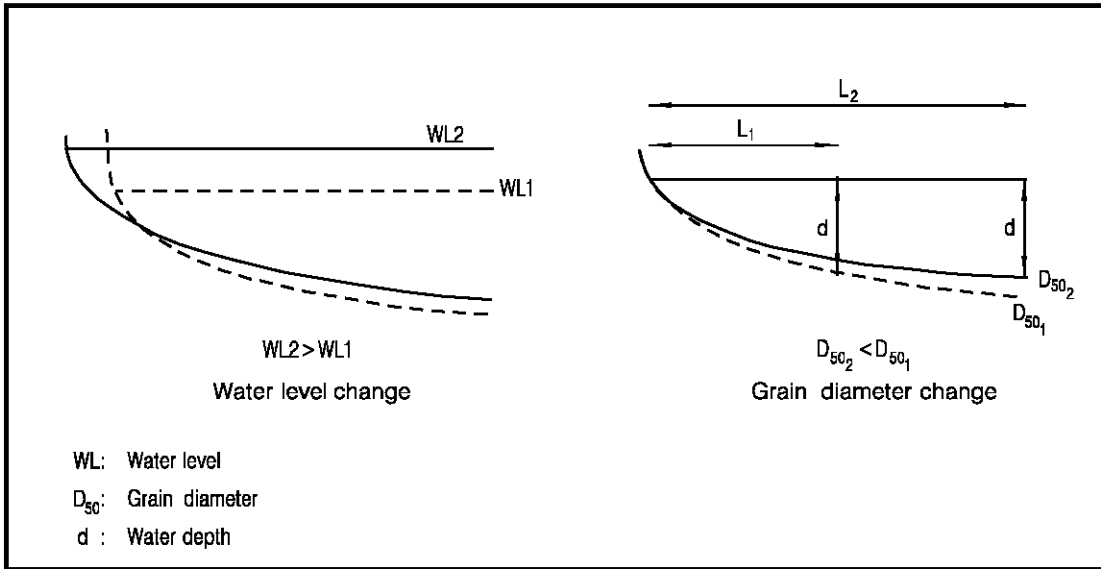

Figure 5 – Variation of Equilibrium Beach Profiles

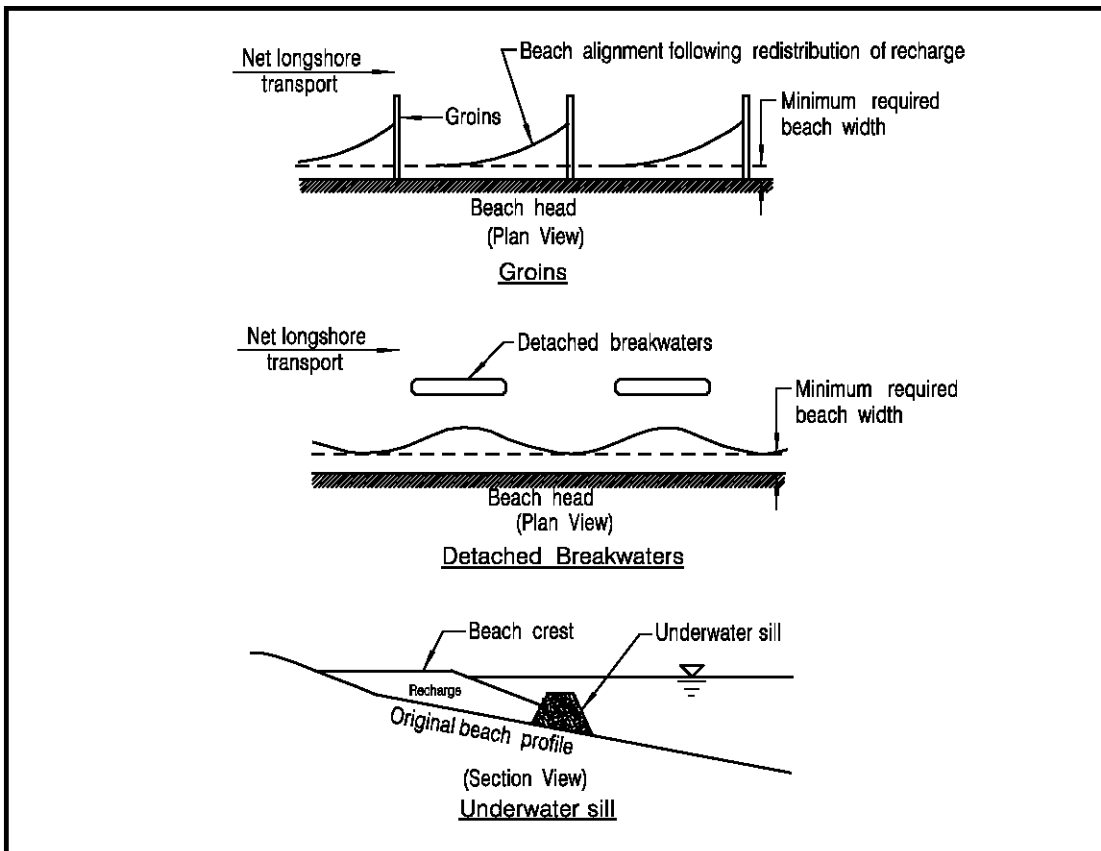

Figure 6 – Beach Protection Measures

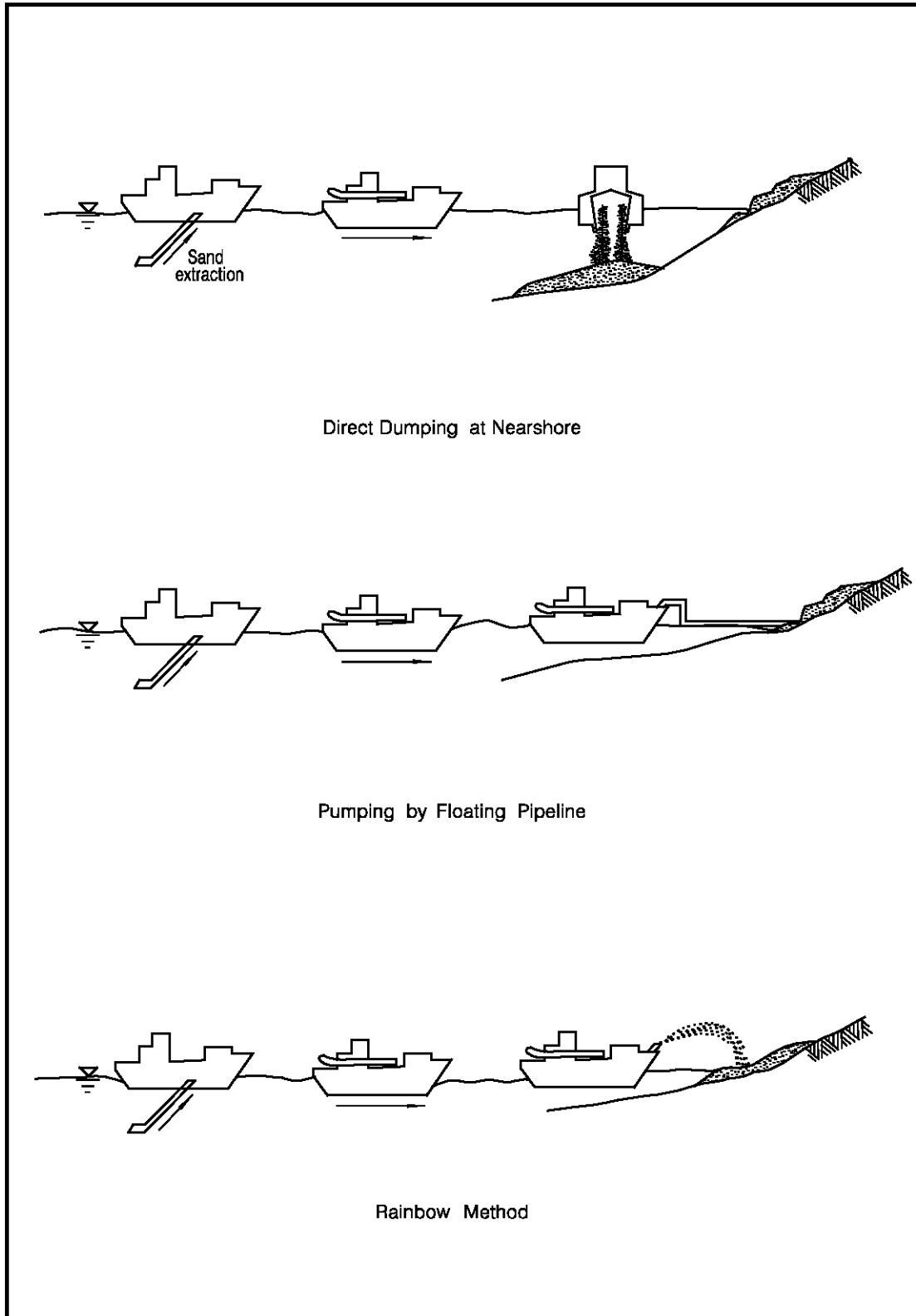

Figure 7 – Sand Placement Methods

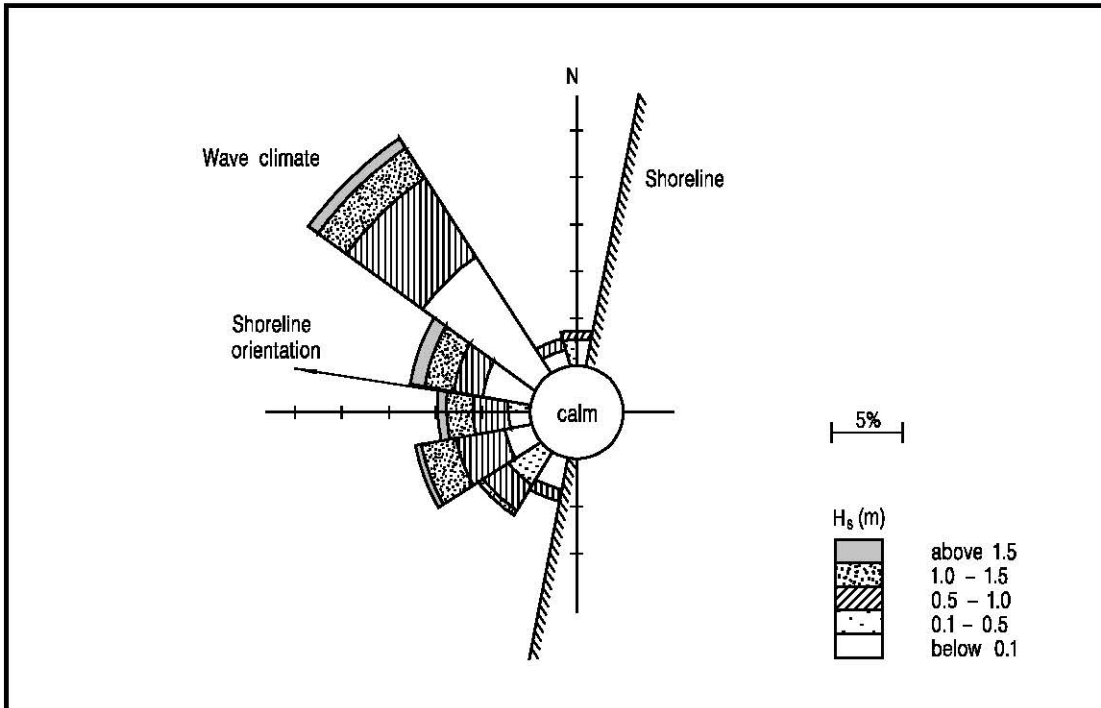

Figure 8 - Wave Rose

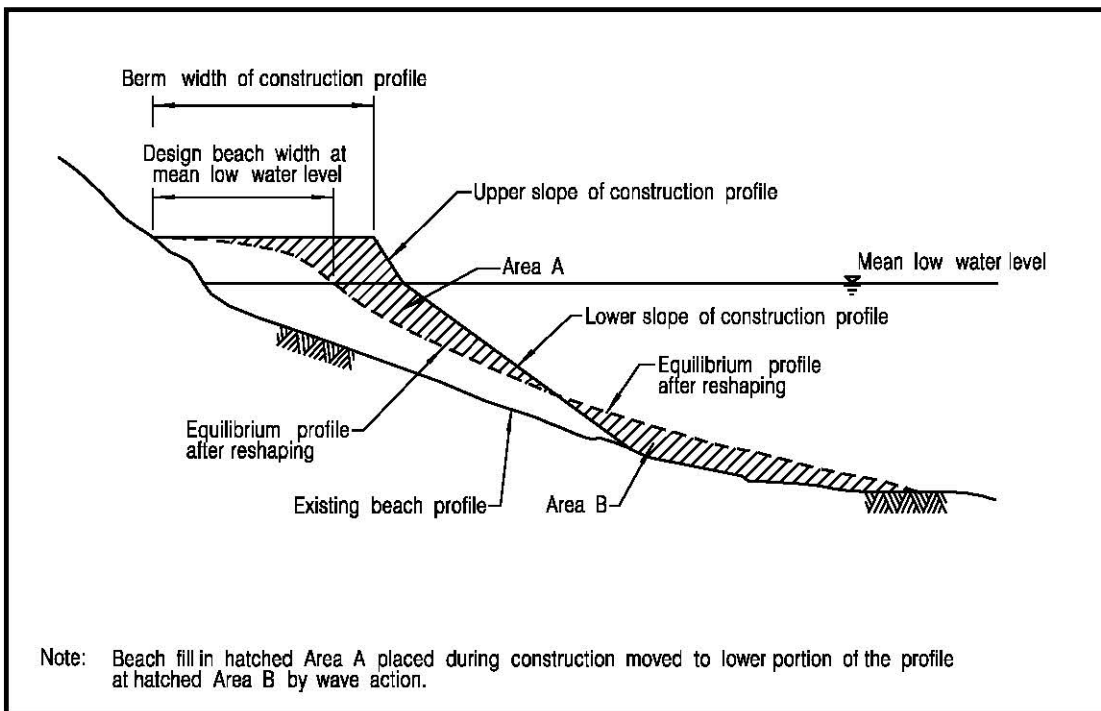

Figure 9 - Construction Profile

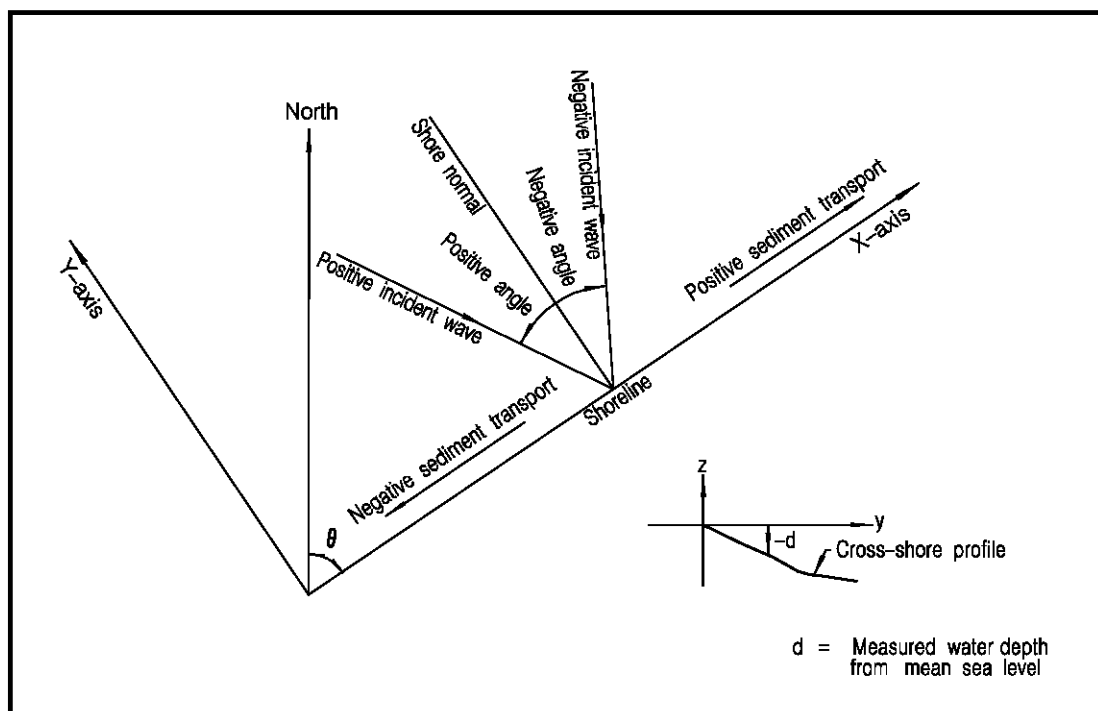

Figure 10 – Coordinate System for Longshore Transport Computation

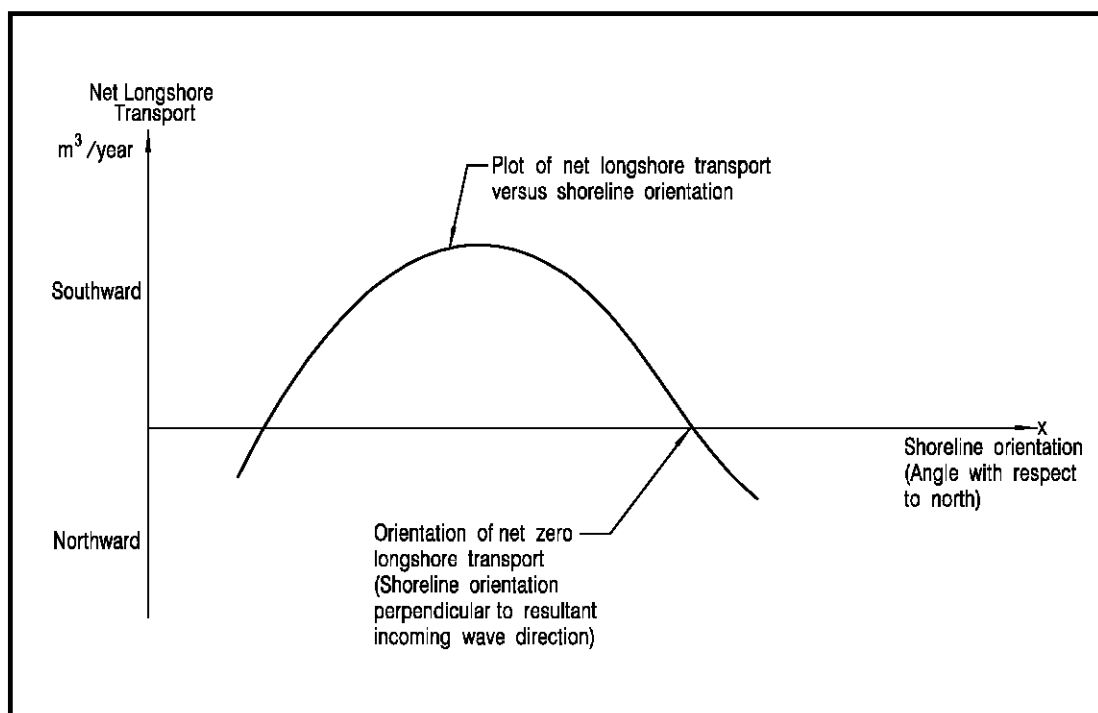

Figure 11 – Variation of Net Longshore Transport with Shoreline Orientation

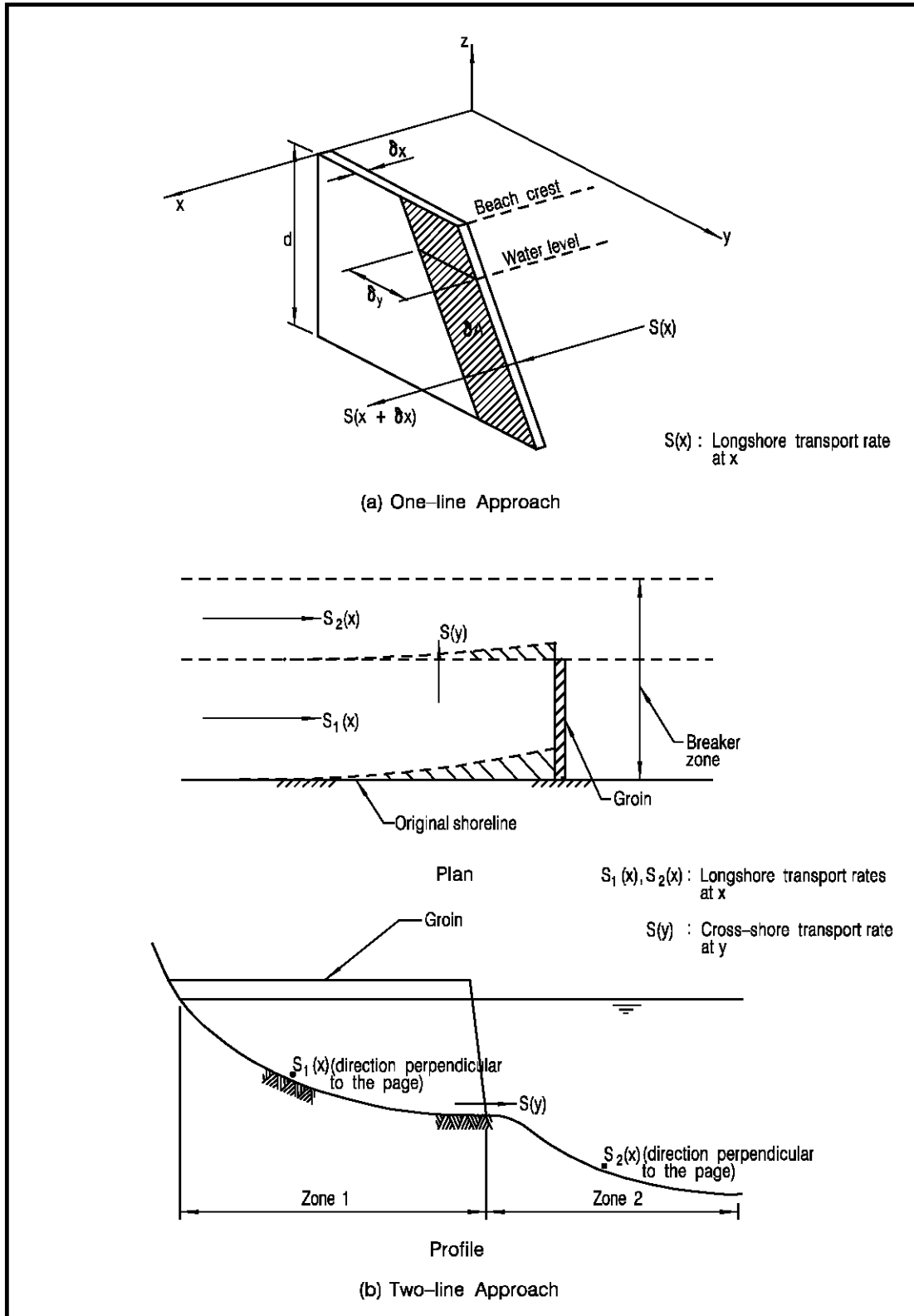

Figure 12 – One-line Approach and Multi-line Approach

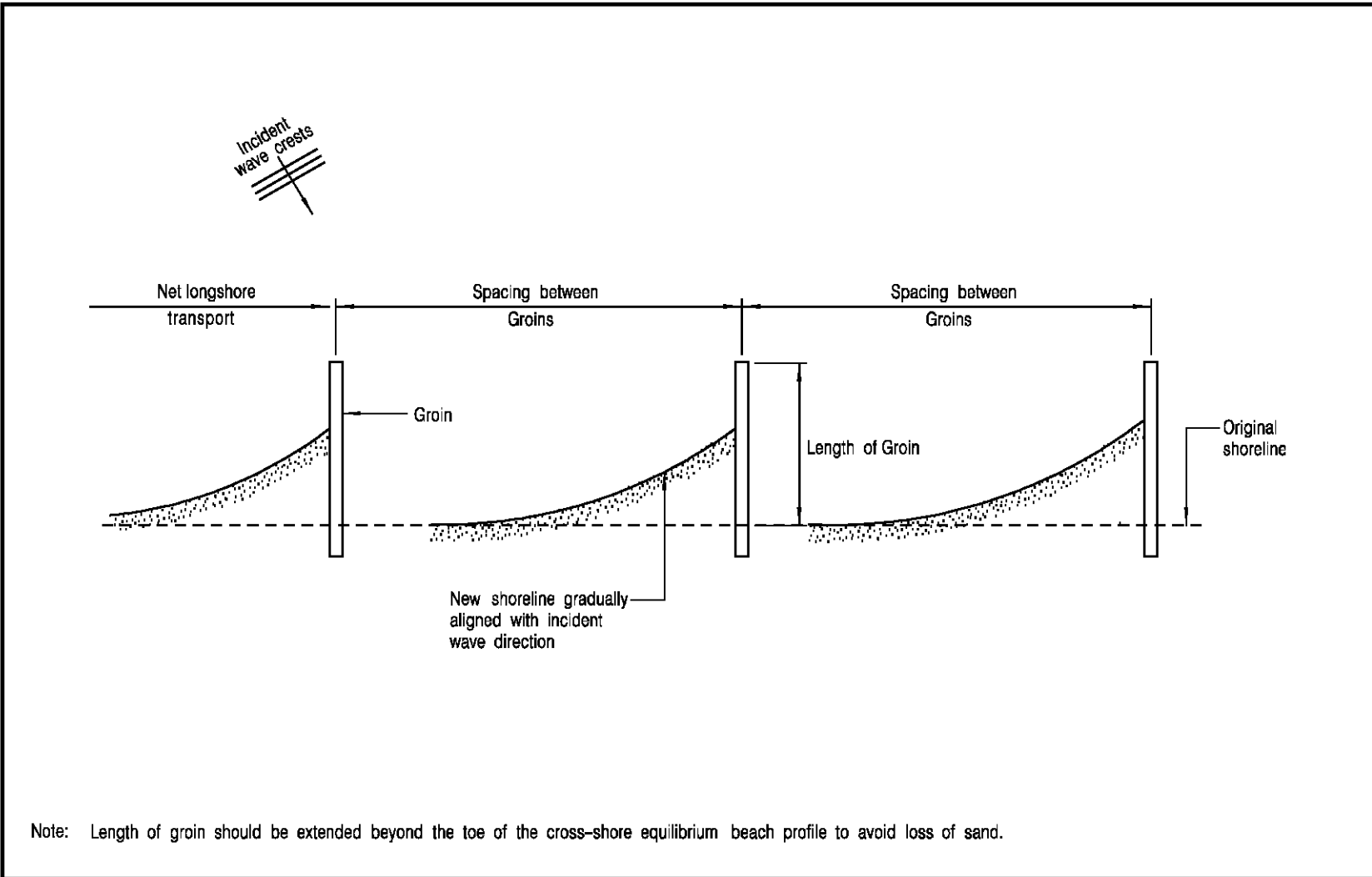

Figure 13 – Groins



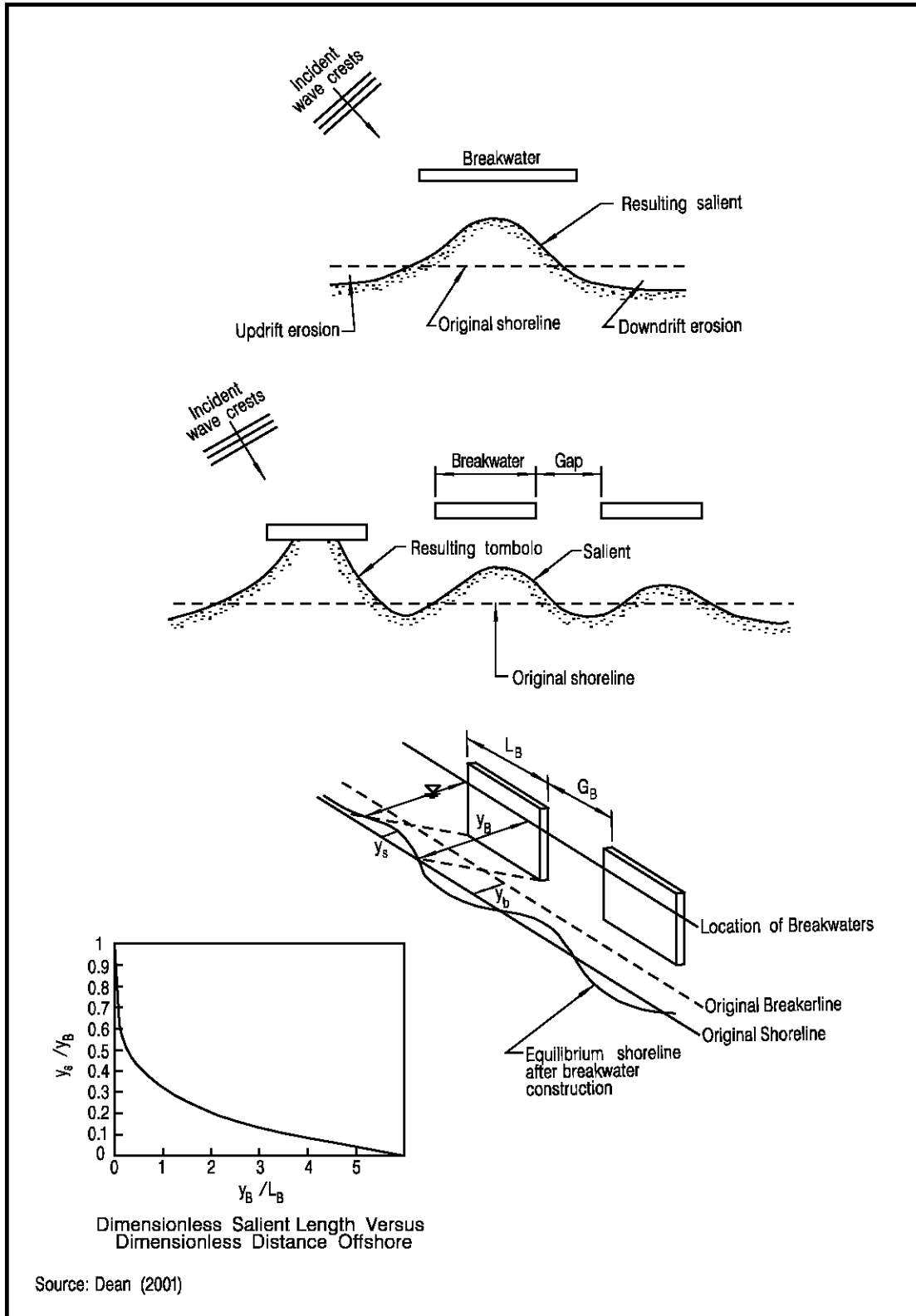

Figure 14 – Detached Breakwaters

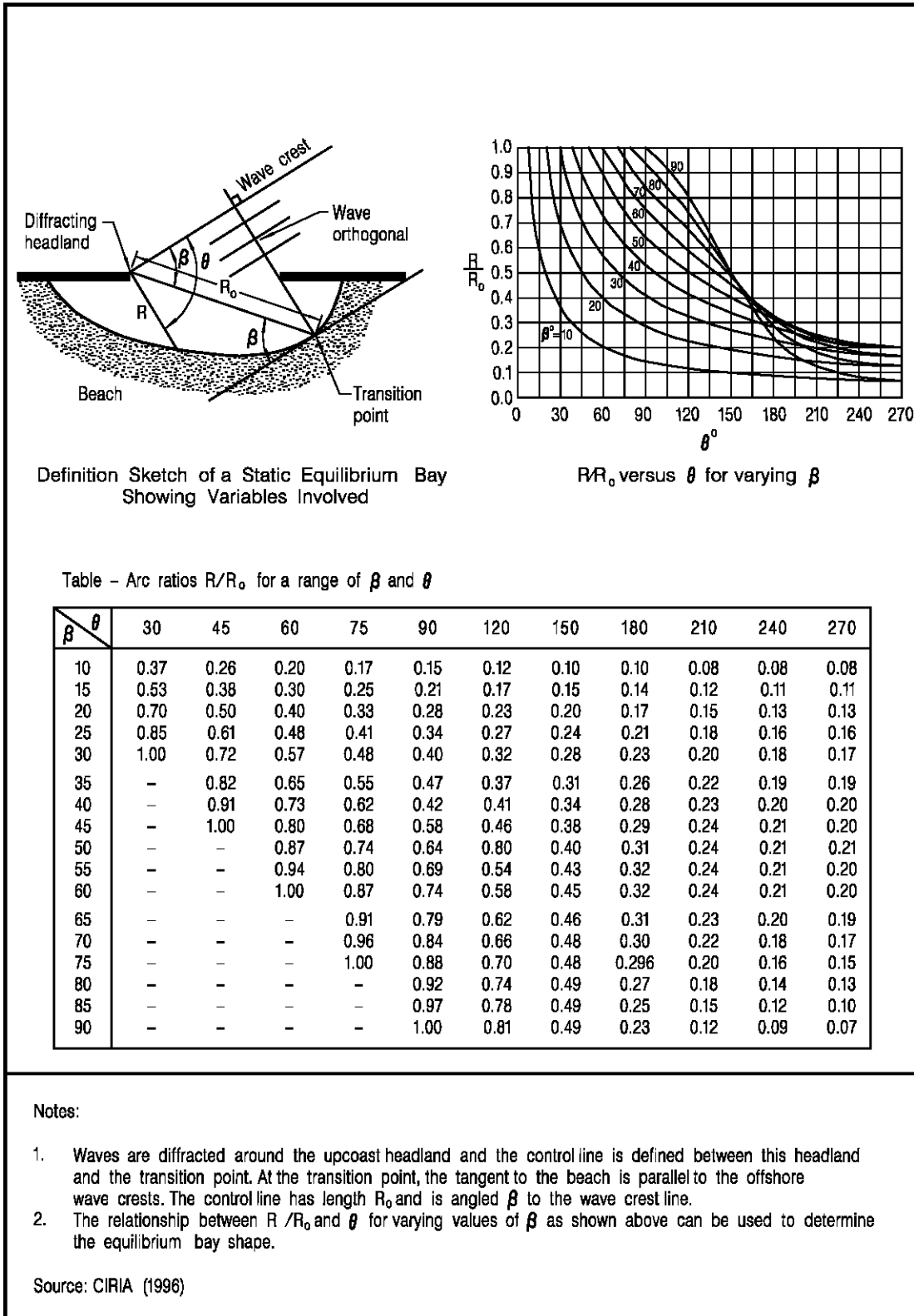

Figure 15 – Artificial Headlands

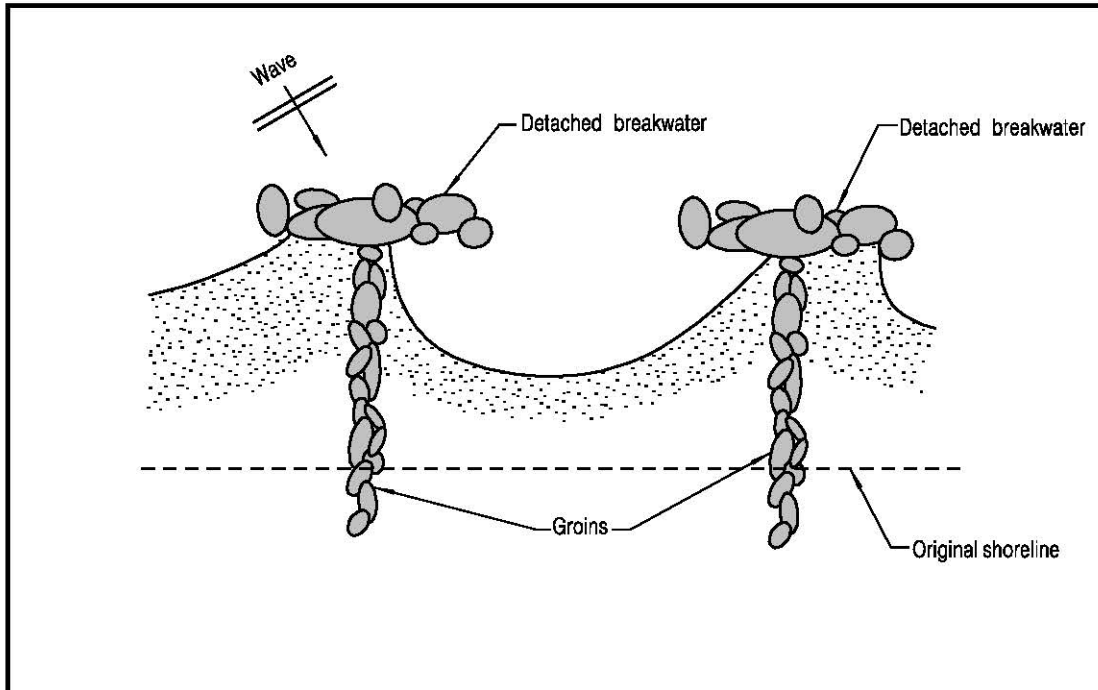

Figure 16 – Formation of Artificial Headlands by Groins and Detached Breakwaters

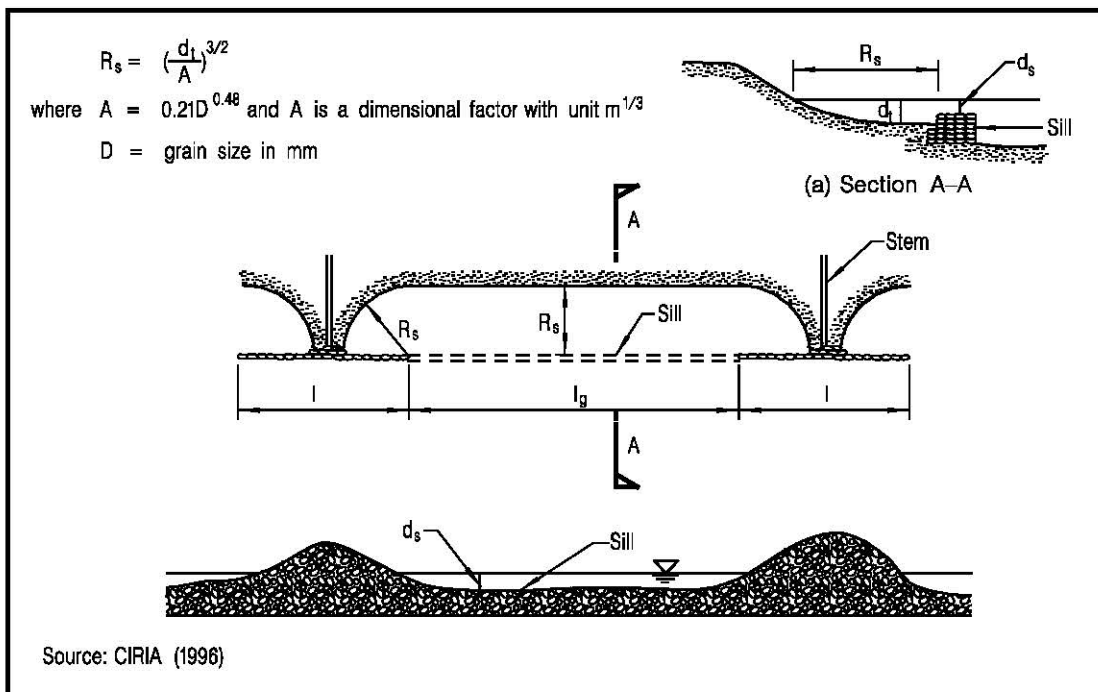

Figure 17 – Configuration of Underwater Sill and Associated Sand Beach of Relatively Mild Slope

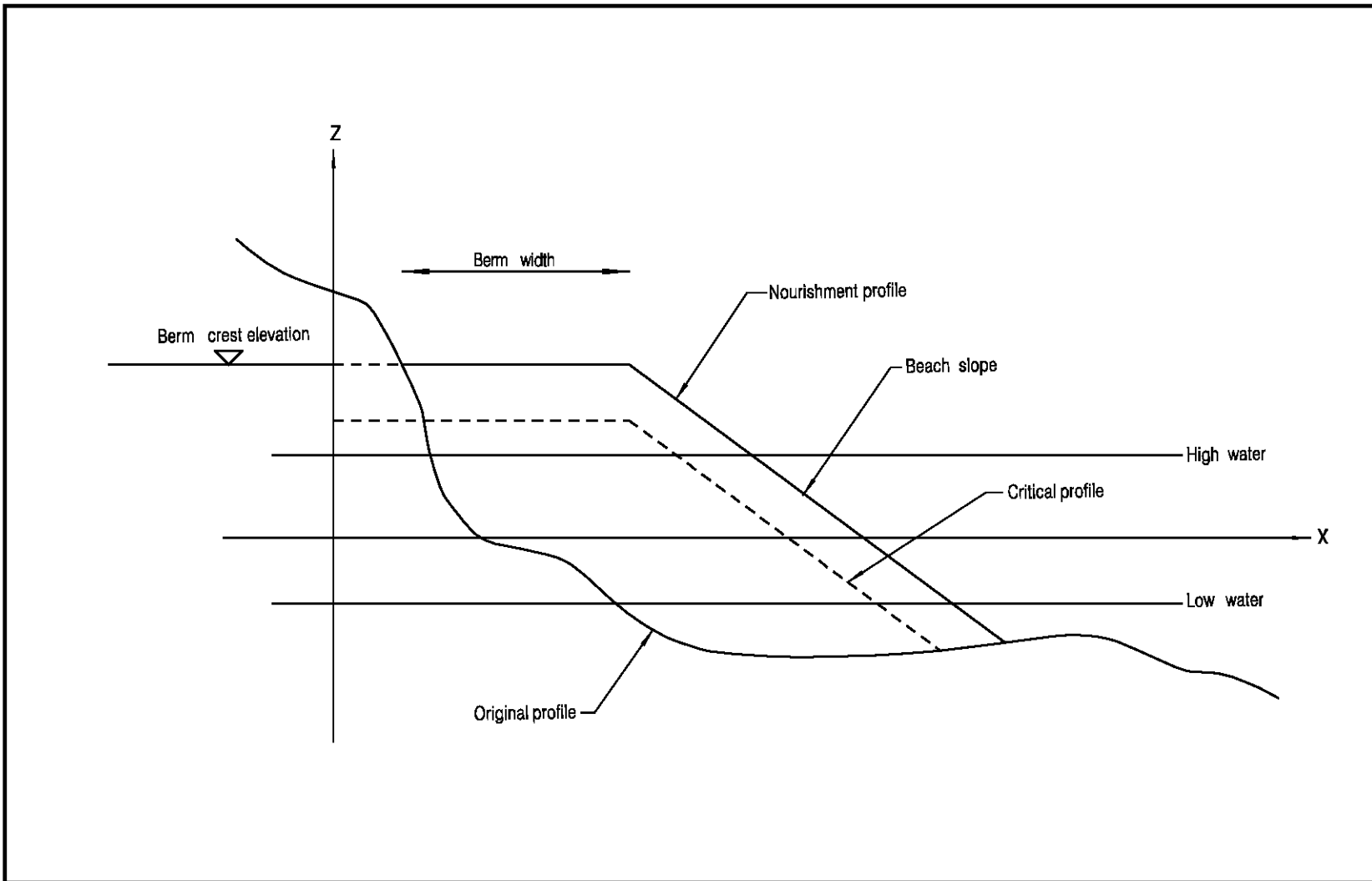

Figure 18 – Monitoring of Beach Profiles